

Handbook

T2550

DIN Rail Controller

About

Title
Part Number
Issue (Date)
Initially
Supplied With

T2550 Handbook

HA 028 898

7 (02/2008)

EurothermSuite Version 4.5

EurothermSuite Tactician Version 4.5

Declaration of Conformity

Manufacturer's name:	Eurotherm Limited
Manufacturer's address:	Faraday Close, Worthing, West Sussex BN13 3PL, United Kingdom
Product type:	T2550 Modular Control System
Model(s):	AI2, AI3, AI4 AO2, DI4, DI6, DI8 DO4, DO8, FI2, RLY4, T2550 IOC, T2550 Backplane. } Including terminal units and accessories
Safety specification:	BS EN61010-1
EMC emissions specification:	BS EN61326-1: 1997 Class A (including amendments A1, A2 and A3)
EMC immunity specification:	BS EN61326-1:1997 Industrial locations (including amendments A1, A2 and A3)

Eurotherm Limited hereby declares that the above products conform to the safety and EMC specifications listed. Eurotherm Limited further declares that the above products comply with the EMC Directive 89 / 336 / EEC amended by 93 / 68 / EEC, and also with the Low Voltage Directive 73 / 23 / EEC.

Signed: _____

W.D. Davis

Dated: 30.01.2007

Signed for and on behalf of Eurotherm Limited
William Davis
(General Manager)

IA249986U690/2(CN23111) Jan 07



© 2008

All rights are strictly reserved. No part of this document may be reproduced, modified, or transmitted in any form by any means, nor may it be stored in a retrieval system other than for the purpose to act as an aid in operating the equipment to which the document relates, without the prior written permission of the manufacturer.

The manufacturer pursues a policy of continuous development and product improvement. The specifications in this document may therefore be changed without notice. The information in this document is given in good faith, but is intended for guidance only. The manufacturer will accept no responsibility for any losses arising from errors in this document.

Restriction of Hazardous Substances (RoHS)

Product group T2550

Table listing restricted substances

Chinese

限制使用材料一览表

产品 T2550	有毒有害物质或元素					
	铅 (Pb)	汞 (Hg)	镉 (Cd)	六价铬(Cr(VI))	多溴联苯(PBB)	多溴二苯醚(PBDE)
IOC	X	0	X	0	0	0
IO 模块	X	0	X	0	0	0
端子模块	X	0	0	X	0	0
基座	X	0	0	0	0	0
0	表示该有毒有害物质在该部件所有均质材料中的含量均在SJ/T11363-2006标准规定的限量要求以下。					
X	表示该有毒有害物质至少在该部件的某一均质材料中的含量超出SJ/T11363-2006标准规定的限量要求。					

English

Restricted Materials Table

Product T2550	Toxic and hazardous substances and elements					
	Pb	Hg	Cd	Cr(VI)	PBB	PBDE
IOC	X	0	X	0	0	0
IO Module	X	0	X	0	0	0
Terminal Unit	X	0	0	X	0	0
Base	X	0	0	0	0	0
0	Indicates that this toxic or hazardous substance contained in all of the homogeneous materials for this part is below the limit requirement in SJ/T11363-2006.					
X	Indicates that this toxic or hazardous substance contained in at least one of the homogeneous materials used for this part is above the limit requirement in SJ/T11363-2006.					

Approval

Name:	Position:	Signature:	Date:
-------	-----------	------------	-------

Martin Greenhalgh

Quality Manager

Martin Greenhalgh

1/FEB/2007



Contents

T2550 Handbook

CHAPTER 1	INTRODUCTION.....	1-1
1.1	MANUAL CONTENTS	1-1
1.2	OTHER INFORMATION SOURCES	1-1
1.3	THE T2550 INSTRUMENT	1-2
1.3.1	Typical applications	1-2
1.3.2	Features	1-3
CHAPTER 2	INSTALLATION	2-1
2.1	SAFETY AND EMC INFORMATION	2-1
2.1.1	Installation requirements for EMC	2-1
2.1.2	Installation safety requirements	2-1
2.1.3	Keeping the product safe	2-2
2.2	UNPACKING	2-3
2.2.1	Handling precautions	2-3
2.2.2	Package contents	2-3
2.3	MECHANICAL LAYOUT AND INSTALLATION	2-4
2.3.1	Layout drawings	2-4
2.3.2	Mount a Base Unit	2-7
2.3.3	Fit a Terminal Unit	2-8
2.3.4	Fit a Module	2-9
2.3.5	Setting the IP Address	2-10
2.4	TERMINAL UNIT SWITCHES	2-12
2.4.1	Switch Location	2-12
2.4.2	Switch and Link functions	2-12
2.5	CONNECTIONS AND WIRING	2-16
2.5.1	Communications	2-17
2.5.2	Configuration Tools	2-20
2.5.3	Power	2-21
2.5.4	Safety Earth	2-21
2.5.5	Watchdog Relay	2-22
2.6	MODBUS COMMUNICATIONS	2-23
2.7	PROFIBUS COMMUNICATIONS	2-23
CHAPTER 3	USER INTERFACE.....	3-1
3.1	INTRODUCTION	3-1
3.2	STATUS LEDS AND SWITCHES	3-3
3.2.1	★ (Status) LED	3-3
3.2.2	X (Fault) LED	3-3
3.2.3	⊥ (Battery) LED	3-3
3.2.4	Ⓒ (Communications) LED	3-3
3.2.5	IP (IP Resolution) LED	3-4
3.2.6	⏏ Duplex LED (Redundant systems only).....	3-4
3.2.7	Watchdog Switch	3-4

Contents - Chapter 3 (Cont.)

3.3	CHANGEOVER AND COMMUNICATIONS LEDS, AND SWITCHES	3-5
3.3.1	Primary LED	3-5
3.3.2	Standby LED	3-5
3.3.3	Sync switch	3-5
3.3.4	Desync switch	3-6
3.3.5	Ethernet (Speed) LED	3-6
3.3.6	Ethernet (Activity) LED	3-6
3.3.7	Ethernet Communications Port	3-6
CHAPTER 4	START-UP	4-1
4.1	REDUNDANCY MODES	4-1
4.2	START-UP MODES	4-1
4.2.1	Hot start (LIN Terminal Unit Only)	4-1
4.2.2	Cold start	4-2
4.2.3	Hot/cold start	4-3
4.2.4	Start-up routine	4-3
4.3	STARTING A SINGLE (SIMPLEX) T2550S Module	4-5
4.3.1	Start-up routine	4-5
4.4	STARTING A PAIR OF (DUPLEX) T2550R MODULES	4-6
4.4.1	Start-up routine	4-6
4.4.2	Two Processor Non-redundant (Simplex) mode	4-8
CHAPTER 5	CONFIGURATION	5-1
5.1	TOOLS: THE AUTOMATIC I/O BUILD AND CONFIGURATION TOOLS	5-1
5.2	AUTOMATIC I/O BUILD	5-2
5.2.1	Preparing for the Automatic I/O Build	5-2
5.3	LINTOOLS	5-4
5.3.1	On-line Reconfiguration	5-4
5.3.2	Preparing to run LINtools	5-5
5.3.3	Running LINtools	5-6
5.4	TERMINAL CONFIGURATOR	5-7
5.4.1	On-line Reconfiguration	5-7
5.5	MODBUS TOOLS	5-8
5.5.1	Preparing to run Modbus Tools	5-8
5.5.2	Running Modbus Tools	5-8
5.5.3	Configuring Profibus Communications using Modbus Tools	5-9

CHAPTER 6	CONTROL AND AUTOTUNING	6-1
6.1	WHAT IS A CONTROL LOOP ?	6-1
6.2	LOOP_PID FUNCTION BLOCK	6-2
6.2.1	Main page	6-3
6.2.2	Set Up page	6-4
6.2.3	PID page	6-5
6.2.4	Tuning Page	6-11
6.2.5	SP page	6-18
6.2.6	OP page	6-20
6.2.7	Diag page	6-24
6.2.8	Alarms page	6-24
6.3	EFFECT OF CONTROL ACTION, HYSTERESIS AND DEADBAND	6-25
6.3.1	Control Action, Setup.CtrlAct	6-25
6.3.2	Hysteresis, Alarms.Hyst	6-25
6.3.3	Deadband, OP.CH2DeadB	6-26
CHAPTER 7	TASK ORGANISATION AND TUNING	7-1
7.1	TASK SCHEDULING	7-1
7.1.1	Tasks	7-1
7.1.2	Priorities	7-1
7.1.3	Functions	7-1
7.2	USER TASKS	7-3
7.2.1	Terminology	7-3
7.2.2	Execution times	7-3
7.2.3	User task block servers	7-4
7.3	USER TASK TUNING	7-6
7.3.1	Initiating repeat rates	7-6
7.3.2	Automatic dynamic tuning	7-6
7.3.3	Manual tuning	7-6
7.4	DATA COHERENCE	7-7
7.4.1	Data flow between tasks	7-7
CHAPTER 8	EVENT LOG	8-1
8.1	THE EVENT LOG	8-1
CHAPTER 9	DATA MANAGEMENT	9-1
9.1	DATA RECORDING	9-1
9.1.1	Data Recording File, .uhh	9-1
9.1.2	Data Recording Groups	9-1
9.2	DATA ARCHIVING	9-2
9.2.1	File Transfer Protocol (FTP)	9-2
9.3	DATA MANAGEMENT CONFIGURATION	9-2

CHAPTER 10	ERROR CONDITIONS AND DIAGNOSTICS	10-1
10.1	ERROR INDICATION TYPES	10-1
10.2	LED ERROR DISPLAYS	10-2
10.2.1	LEDs	10-2
10.2.2	Instrument failure modes	10-4
10.2.3	Power failure	10-4
10.2.4	Watchdog failure	10-4
10.2.5	Inter-processor Communications Mechanism for redundancy failure	10-5
10.2.6	LIN failure	10-5
10.2.7	Decoupled Instruments	10-6
10.2.8	Desynchronisation	10-6
10.3	POWER-UP FAILURE	10-7
10.3.1	Power-up routine	10-7
10.4	POWER ON SELF TESTS (POSTs)	10-9
10.5	DIAGNOSTIC BLOCKS	10-10
CHAPTER 11	SERVICE	11-1
11.1	PREVENTIVE MAINTENANCE SCHEDULE	11-1
11.2	REPLACEMENT PROCEDURES	11-2
11.2.1	Firmware upgrade	11-2
11.2.2	Live T2550R Module replacement	11-3
11.2.3	Battery replacement (Simplex only)	11-3
APPENDIX A	SPECIFICATION AND COSHH	A-1
A.1	INSTALLATION CATEGORY AND POLLUTION DEGREE	A-1
A.1.1	Installation category II	A-1
A.1.2	Pollution degree 2	A-1
A.2	SPECIFICATION	A-2
A.2.1	General specification	A-2
A.2.2	T2550 Terminal Unit specification	A-3
A.2.3	T2550 IOC Module hardware specification	A-4
A.2.4	T2550 LIN IOC Module software specification	A-5
A.3	COSHH - BATTERY SPECIFICATION	A-8
APPENDIX B	POWER ON SELF TESTS (POSTs) AND ERROR NUMBERS	B-1
B.1	POWER ON SELF TESTS (POSTs)	B-1
B.2	ERROR NUMBERS	B-4
B.2.1	Error number structure	B-4
B.2.2	Error messages	B-4

APPENDIX C	TERMINAL CONFIGURATOR	C-1
C.1	THE CONFIGURATOR	C-1
	C.1.1 Configurable Items	C-1
C.2	RUNNING THE CONFIGURATOR	C-2
	C.2.1 Initial menu access	C-2
	C.2.2 The Initial menu	C-3
	C.2.3 Quitting the Terminal Configurator	C-3
C.3	LIN DATABASE CONFIGURATION	C-4
	C.3.1 MAKE command	C-4
	C.3.2 COPY command	C-10
	C.3.3 DELETE command	C-11
	C.3.4 INSPECT command	C-11
	C.3.5 NETWORK command	C-12
	C.3.6 UTILITIES command	C-13
	C.3.7 ALARMS command	C-15
C.4	MODBUS CONFIGURATION	C-16
	C.4.1 GWindex command	C-16
	C.4.2 MODE command	C-16
	C.4.3 INTERFACE command	C-17
	C.4.4 SETUP command	C-17
	C.4.5 TABLES command	C-19
APPENDIX D	I/O MODULES	D-1
D.1	INTRODUCTION	D-1
D.2	ISOLATOR LINKS AND FUSES (OPTIONAL FOR I/O TERMINAL UNITS ONLY)	D-1
	APPENDIX D1 2500P - 24V POWER SUPPLY	D1-1
D1.1	DESCRIPTION	D1-1
D1.2	MODULE IDENTIFICATION	D1-1
D1.3	CONFIGURATION	D1-1
D1.4	LOCATION	D1-1
D1.5	TERMINAL CONNECTIONS	D1-2
D1.6	STATUS INDICATION	D1-3
D1.7	SPECIFICATIONS	D1-4
	D1.7.1 2500P Module	D1-4
D1.8	MOUNT THE POWER SUPPLY	D1-5
	D1.8.1 DIN Rail Mounting	D1-5
	APPENDIX D2 AI2 - TWO CHANNEL ANALOGUE INPUT MODULE	D2-1
D2.1	DESCRIPTION	D2-1
D2.2	TERMINAL CONNECTIONS	D2-2
D2.3	ANALOGUE INPUTS	D2-4
	D2.3.1 Isolation Diagram	D2-4
	D2.3.2 Equivalent Circuits	D2-4
D2.4	STATUS INDICATION	D2-6
D2.5	SPECIFICATIONS	D2-7
	D2.5.1 AI2 TC Module	D2-7
	D2.5.2 AI2 DC Module	D2-8
	D2.5.3 AI2 mA Module	D2-10

APPENDIX D3	AI3 - THREE CHANNEL ANALOGUE INPUT MODULE	D3-1
D3.1	DESCRIPTION	D3-1
D3.2	TERMINAL CONNECTIONS	D3-2
D3.3	ANALOGUE INPUTS	D3-3
	D3.3.1 Isolation Diagram	D3-3
	D3.3.2 Equivalent Circuits	D3-3
D3.4	HART COMPATIBILITY	D3-4
D3.5	STATUS INDICATION	D3-5
D3.6	SPECIFICATIONS	D3-6
	D3.6.1 AI3 Module	D3-6
APPENDIX D4	AI4 - FOUR CHANNEL ANALOGUE INPUT MODULE	D4-1
D4.1	DESCRIPTION	D4-1
D4.2	TERMINAL CONNECTIONS	D4-2
D4.3	ANALOGUE INPUTS	D4-3
	D4.3.1 Isolation Diagram	D4-3
	D4.3.2 Equivalent Circuits	D4-3
D4.4	STATUS INDICATION	D4-5
D4.5	SPECIFICATIONS	D4-6
	D4.5.1 AI4 TC Module	D4-6
	D4.5.2 AI4 mV Module	D4-7
	D4.5.3 AI4 mA Module	D4-8
APPENDIX D5	AO2 - TWO CHANNEL ANALOGUE OUTPUT MODULE	D5-1
D5.1	DESCRIPTION	D5-1
D5.2	TERMINAL CONNECTIONS	D5-2
D5.3	ANALOGUE OUTPUTS	D5-3
	D5.3.1 Isolation Diagram	D5-3
	D5.3.2 Equivalent Diagram	D5-3
D5.4	STATUS INDICATION	D5-4
D5.5	SPECIFICATIONS	D5-5
	D5.5.1 AO2 Module	D5-5
APPENDIX D6	DI4 - FOUR CHANNEL DIGITAL INPUT MODULE	D6-1
D6.1	DESCRIPTION	D6-1
D6.2	TERMINAL CONNECTIONS	D6-2
D6.3	DIGITAL INPUTS	D6-3
	D6.3.1 Isolation Diagram	D6-3
	D6.3.2 Equivalent Circuits	D6-4
D6.4	STATUS INDICATION	D6-5
D6.5	SPECIFICATIONS	D6-6
	D6.5.1 DI4 Module	D6-6

APPENDIX D7	DI6 - SIX CHANNEL AC DIGITAL INPUT MODULE	D7-1
D7.1	DESCRIPTION	D7-1
D7.2	TERMINAL CONNECTIONS	D7-2
	D7.2.1 V-I CURVES FOR INPUTS	D7-3
D7.3	DIGITAL INPUTS	D7-4
	D7.3.1 Isolation Diagram	D7-4
	D7.3.2 Equivalent Circuits	D7-5
D7.4	STATUS INDICATION	D7-6
D7.5	SPECIFICATIONS	D7-7
	D7.5.1 DI6 Module	D7-7
APPENDIX D8	DI8 - EIGHT CHANNEL DIGITAL INPUT MODULE	D8-1
D8.1	DESCRIPTION	D8-1
D8.2	TERMINAL CONNECTIONS	D8-2
D8.3	DIGITAL INPUTS	D8-3
	D8.3.1 Isolation Diagram	D8-3
	D8.3.2 Equivalent Circuits	D8-4
D8.4	STATUS INDICATION	D8-5
D8.5	SPECIFICATIONS	D8-6
	D8.5.1 DI8 Module	D8-6
APPENDIX D9	DO4 - FOUR CHANNEL DIGITAL OUTPUT MODULE	D9-1
D9.1	DESCRIPTION	D9-1
D9.2	TERMINAL CONNECTIONS	D9-2
D9.3	DIGITAL OUTPUTS	D9-3
	D9.3.1 Isolation Diagram	D9-3
	D9.3.2 Equivalent Circuits	D9-4
D9.4	STATUS INDICATION	D9-5
D9.5	SPECIFICATIONS	D9-6
	D9.5.1 DO4 Module	D9-6
APPENDIX D10	DO8 - EIGHT CHANNEL DIGITAL OUTPUT MODULE	D10-1
D10.1	DESCRIPTION	D10-1
D10.2	TERMINAL CONNECTIONS	D10-2
D10.3	DIGITAL OUTPUTS	D10-3
	D10.3.1 Isolation Diagram	D10-3
	D10.3.2 Equivalent Circuits	D10-4
D10.4	STATUS INDICATION	D10-5
D10.5	SPECIFICATIONS	D10-6
	D10.5.1 DO8 Module	D10-6

APPENDIX D11	RLY4 - RELAY MODULE	D11-1
D11.1	DESCRIPTION	D11-1
	D11.1.1 Snubber Circuits	D11-1
D11.2	TERMINAL CONNECTIONS	D11-2
D11.3	RELAY OUTPUTS	D11-3
	D11.3.1 Isolation Diagram	D11-3
D11.4	STATUS INDICATION	D11-4
D11.5	SPECIFICATIONS	D11-5
	D11.5.1 RLY4 Module	D11-5
D11.6	RELAY MODULE SNUBBER CIRCUITS REMOVAL	D11-6
	D11.6.1 Instructions	D11-6
APPENDIX D12	FI2 - TWO CHANNEL FREQUENCY INPUT MODULE	D12-1
D12.1	DESCRIPTION	D12-1
D12.2	TERMINAL CONNECTIONS	D12-2
D12.3	APPLICATION DETAILS	D12-4
D12.4	FREQUENCY INPUTS	D12-5
	D12.4.1 Isolation Diagram	D12-5
	D12.4.2 Equivalent Circuits	D12-5
D12.5	STATUS INDICATION	D12-7
D12.6	FAULT DETECTION	D12-8
	D12.6.1 Fault Diagnostics	D12-8
D12.7	SPECIFICATIONS	D12-9
	D12.7.1 FI2 Module	D12-9
D12.8	CONFIGURE CHANNEL VOLTAGE SETTING	D12-11
	D12.8.1 Instructions	D12-11
APPENDIX D13	ZI - ZIRCONIA INPUT MODULE	D13-1
D13.1	DESCRIPTION	D13-1
D13.2	TERMINAL CONNECTIONS	D13-2
D13.3	APPLICATION DETAILS	D13-3
	D13.3.1 Temperature Control	D13-3
	D13.3.2 Carbon Potential Control	D13-3
	D13.3.3 Soot Alarm	D13-3
	D13.3.4 Probe Cleaning	D13-3
	D13.3.5 Endothermic Gas Correction	D13-3
D13.4	ANALOGUE INPUTS	D13-4
	D13.4.1 Isolation Diagram	D13-4
	D13.4.2 Equivalent Circuits	D13-4
D13.5	STATUS INDICATION	D13-5
D13.6	FAULT DETECTION	D13-6
	D13.6.1 Fault Diagnostics	D13-6
D13.7	SPECIFICATIONS	D13-8
	D13.7.1 ZI Module	D13-8
INDEX	INDEX-1

CHAPTER 1 INTRODUCTION

The T2550 instrument is a high integrity controller and can be used stand-alone or part of a complete control system which includes communications to I/O modules and Human Machine Interfaces (HMI).

1.1 MANUAL CONTENTS

This manual is divided into the following chapters:

- Chapter 1. Introduction
- Chapter 2. Installation
- Chapter 3. User Interface (explaining the Module LEDs and switches)
- Chapter 4. Start-Up (step-by-step instrument start-up or re-start instructions, Automatic I/O build instructions)
- Chapter 5. Configuration (basic overview of using LINtools to modify control strategy and communications protocols on site, usually to match changes in the plant being controlled). (Initial configuration, to Customer Specification, is normally carried out prior to delivery.)
- Chapter 6. Control and Automatic Tuning (explaining Control Loop configuration)
- Chapter 7. Task Organisation and Tuning (explaining tasks and tuning)
- Chapter 8. Event Log (explaining the Event Log facility)
- Chapter 9. Data Management (explaining the data recording and archiving of Data Recording files, .uhh)
- Chapter 10. Error Conditions and Diagnostics (how to diagnose faults that develop in the instrument, by recognising fault indications)
- Chapter 11. Service
- Appendix A. Technical Specification and COSHH (Batteries contain a hazardous substance, the Control of Substances Hazardous to Health Regulations 2002 (COSHH) require employers to control exposure to hazardous substances to prevent ill health.)
- Appendix B. Power On Self Tests (POSTs) and Error Numbers. A list of applicable POSTs and error numbers that may help to diagnose faults that develop in the instrument.
- Appendix C. Terminal Configurator (overview of the instructions for connecting and using the Terminal Configurator)
- Appendix D. I/O Modules. Individual chapters for each of the compatible I/O modules, including Technical Specification and details for both standard and Fast I/O Task modules.

1.2 OTHER INFORMATION SOURCES

For details of Local Instrument Network (LIN) based Function Blocks, their parameters and input/output connections refer to the *LIN Blocks Reference Manual* (Part no. HA082375U003) which explains how control strategy function blocks are selected interconnected etc. The creation, monitoring and On-line Reconfiguration of LIN Databases and LIN Sequential Function Charts (SFCs) is described in the *LINtools Help* (Part no. RM263001U055). The *ELIN User Guide* (Part no. HA082429) gives full details of installation, and how to configure an ELIN network, including setting the IP address using the instruments internal configurator.

The future development of the Modbus and Profibus implementations will be discussed in the *Communications Manual* (Part no. HA028014).

Note If you do not possess any documents stated please contact your distributor.

1.3 THE T2550 INSTRUMENT

The T2550 instrument comprises the Base Unit (T2550B), holding up to 16 I/O modules (2500M), and either a single (Simplex) module (T2550S) or a pair of (Duplex) modules (T2550R).

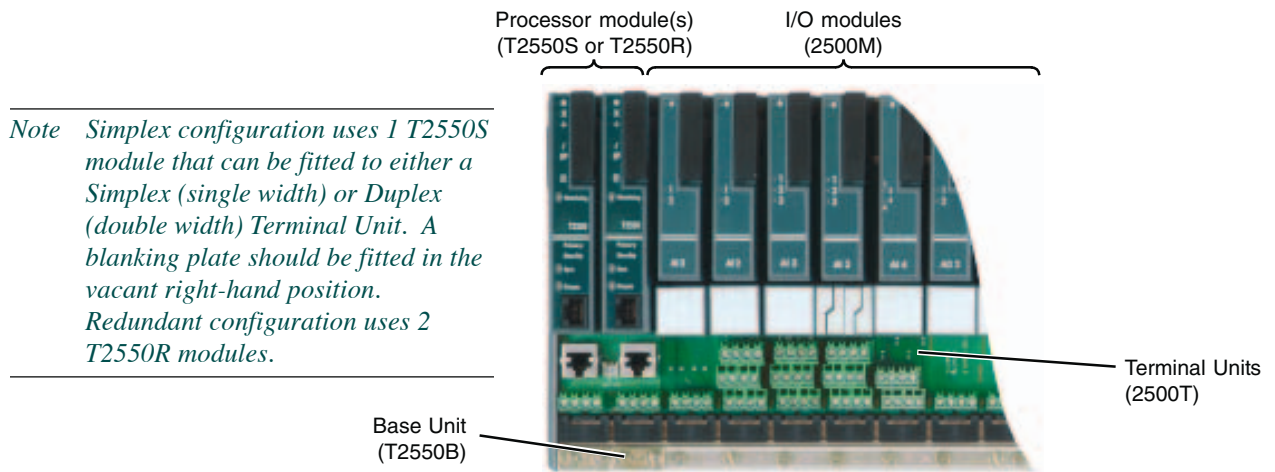

Note Simplex configuration uses 1 T2550S module that can be fitted to either a Simplex (single width) or Duplex (double width) Terminal Unit. A blanking plate should be fitted in the vacant right-hand position. Redundant configuration uses 2 T2550R modules.

Figure 1.1 Redundant (T2550R) Modules configuration with I/O Modules (16) on the Base Unit

1.3.1 Typical applications

The T2550 instrument is designed to control plants using local input/output modules, refer to the *I/O Module Appendix*. A number of these instruments can be networked together, allowing thousands of I/O points to be monitored and controlled.

Type	Description	Slow I/O Task (110ms)	Fast I/O Task (10ms)
AI2	Analogue I/P 2 channels (universal; 3 Terminal Unit options)	✓	-
AI3	Analogue I/P 3 channels (4-20mA, with transmitter PSU)	✓	-
AI4	Analogue I/P 4 channels (TC, mV, mA Terminal Unit options)	✓	-
AO2	Analogue O/P 2 channels (0-20mA or 0-10V output)	✓	-
DI4	Digital I/P 4 channels (logic)	✓	-
DI8_LG*	Digital I/P 8 channels (logic)	✓	✓
DI8_CO*	Digital I/P 8 channels (contact closure)	✓	✓
DI6_MV	Digital I/P 6 channels (ac mains input, 115V rms)	✓	-
DI6_HV	Digital I/P 6 channels (ac mains input, 230V rms)	✓	-
DO4_LG*	Digital O/P 4 channels (externally powered, 10mA)	✓	✓
DO4_24*	Digital O/P 4 channels (externally powered, 100mA)	✓	✓
DO8	Digital O/P 8 channels	✓	✓
RLY4*	Relay O/P 4 channels (2 amp; 3 n/o, 1 change-over)	✓	✓
FI2	Frequency I/P 2 channels (logic, magnetic, and contact closure)	✓	✓
ZI	Zirconia Probe I/P 2 channels (mV (TC), high impedance 0-2V)	✓	-

Note. * indicates the Module upgraded, refers to Version 2 modules.

Table 1.3.1 Module compatibility

1.3.2 Features

The main features of the T2550 instrument are as follows:

LIN

The Local Instrument Network (LIN) is a collection of LIN instruments, and LIN communications, etc. that together form the control system.

LIN COMMUNICATION

The Local Instrument Network (LIN) communications is our proprietary communications system used to connect each LIN instrument in the network.

ELIN COMMUNICATION

ELIN communication is the LIN communications system transported via Ethernet. It allows peer-to-peer communications between T2550s and the wider network via a standard Ethernet infrastructure, see *Connections and Wiring*.

PROFIBUS COMMUNICATION

The Profibus communications is an industry standard open network and can be used to connect a T2550 Profibus Slave to a Profibus Master in the network.

Note Profibus Slave communication parameters are configured using Modbus Tools.

REDUNDANT POWER SUPPLY CONNECTION

The Duplex Terminal Units supports Redundant Power Supply Connection. This is two power connectors, OR'ed together at the Terminal Unit that permits connection of a redundant power supply.

The Duplex Terminal Unit supports data in SRAM and the Real-Time Clock for a minimum of 12 hours with an internal supercapacitor.

The Simplex Terminal Unit will support data in SRAM and the Real-Time Clock for a minimum of 72 hours with an additional battery.

Note Provision has been made for the connection of an external battery to extend this time via a socket sited between the Serial Communication ports on the Duplex Terminal Unit.

REDUNDANT INSTRUMENT

The instrument can be set up for redundant (Duplex - LIN or Profibus) or non-redundant (Simplex) operation. When operating in redundant mode, a high speed data link (Inter-processor Communications Mechanism - ICM) between the primary and secondary T2550R modules provides exact tracking of the control database, allowing bumpless changeover by the secondary module should the primary module fail.

LIVE T2550(R OR S) REPLACEMENT

Live replacement of a failed T2550(R or S) module can be carried out, without wiring disconnections. Full hardware and software status indication allows rapid verification and diagnostics. When operating in Simplex mode ALL I/O modules power down when the T2550S is extracted. However, during Redundant mode operation either T2550R module can independently drive the I/O modules allowing the replacement T2550R to load its control strategy and current status from the active T2550R.

AUTOMATIC CHANGEOVER

Changeover of control by the secondary module in the event of primary module failure is automatic and seemingly bumpless to the I/O. There is no loss of I/O states and no need to re-initialise I/O points. Revalidation of all attached LIN nodes is automatic.

1.3.2 FEATURES (Cont.)

DATA MANAGEMENT

Automatic data recording and archiving, providing Data Recording files, .uhh, to store recorded values from defined parameters selected from the database in the instrument. The .uhh files can be automatically archived to defined FTP Servers, and then displayed as a charts using the Review software.

EVENT LOGGING

Automatic event logging, providing an ASCII text file to record and store individually time stamped events generated in the instrument, and provide a means of indicating the impact of an event on the system.

HEALTH MONITORING

Automatic health checks, self-testing, and initialisation on power-up, with continuous checking of I/O status and external communications.

FRONT PANEL ANNUNCIATION

Instrument LEDs are provided for communications and module status. Control switches are also fitted on each T2550R module.

WATCHDOG

Watchdog switch for each T2550R module to manually initiate a restart in the event of a watchdog failure of a T2550R module, see *Switch and Link functions*. If required, the Watchdog Relay connections can be wired, see *Connections and Wiring*.

CONFIGURATION

Continuous strategies and Sequences are configured/downloaded/monitored with LINtools, the recommended configuration tool.

AUTOMATIC CONFIGURATION

The instrument is capable of automatically creating its own LIN Database (_auto.dbf and _auto.run), including all necessary module and I/O Function Blocks based on the I/O detected in the Base Unit.

Automatic Configuration is attempted after the instrument has determined the Hot/Cold Start switch configuration. A Duplex Unit uses Switch 2 (SW2:S2 and SW2:S3 are set to OFF). A Simplex Unit has only 1 bank of switches Switch 1 (SW1:S9 and SW1:S10 are set to OFF). This instructs the instrument to detect the installed I/O, and when complete, an operational database is created and run automatically.

BLOCK STRUCTURE

Continuous strategies are built up by interconnection of fixed function blocks from a comprehensive library of analogue and logic elements, common to all LIN based instruments.

ST USER ALGORITHMS

Special ACTION blocks support user-algorithms written in Structured Text (ST) and are well-suited to implement plant logical devices.

1.3.2 FEATURES (Cont.)

SEQUENTIAL FUNCTION CHART (SFC)

The Sequential Function Chart (SFC) is the graphical way LINtools (the recommended Configuration tool) represents a LIN Sequence (.sfc). A Sequence is employed when the process being controlled by the LIN Database (.dbf) can adopt several distinct states - e.g. 'Starting Up', 'Full Running', 'Shutting Down', etc. A LIN Sequence is a program that runs in a LIN instrument, in conjunction with a LIN Database. It interacts with its associated LIN Database by writing new values to specified LIN Database fields, in response to changes in the values of other specified LIN Database fields.

Note If loading and unloading Sequences is not kept to a minimum when redundant instruments are synchronising the secondary may fail to load an Sequential Function Chart (SFC) and may cause the redundant instruments to desynchronise.

LADDER CONFIGURATION

A ladder diagram is a type of Action represented graphically by a column of 'rungs'. Rungs are equivalent to program statements, with icons along them representing digital or analog fields, constants, and logical or arithmetic functions. Each rung has only one 'output' or 'objective' - at its right-hand end - which is either a coil (digital field), variable (analogue field), or a 'jump' to another labelled rung.

Note A single rung that evaluates TRUE or FALSE can also be used for a Sequence Transition.

Rungs can include any number of input elements and use any complexity of wired or explicit functions to perform the rung operation - subject only to screen space limitations.

BLOCK SUPPORT

Most LIN Database function blocks are supported in redundant mode. Special diagnostic blocks are available for hardware and software status reporting, refer to *Diagnostics blocks section* for a list of typically required diagnostic blocks, and the *LIN Blocks Reference Manual* (Part no. HA082375U003) for a full description of each individual block.

Blocks are license protected into categories that define an increasing level of instrument control. Foundation license blocks define a basic level of instrument control that will simply provide an output derived from a given input. Standard license blocks define a level of instrument control that provides an output derived from a given input using simple blocks. Control license blocks define a level of instrument control that provides an output derived using more complex blocks that can reduce the total number of blocks needed in the database.

Note Generally, a combination of Standard license blocks can be used to provide a level of instrument control equivalent to a single Control license block, but this will impact on the total number of available blocks remaining.

Advanced license blocks define a level of instrument control that provides an output derived from a given input by using market applicable blocks. Login license blocks define a level of instrument control that provides Data Management functionality to outputs derived from a given input.

1.3.2 FEATURES (Cont.)

ENCLOSURES

The T2550 instruments can be supplied in a range of enclosures, both wall-mounted and floor-standing. Power supplies, standard terminations, transmitter power supplies, and I/O modules can all be fitted within these enclosures, and if required, a Human Machine Interface (HMI - contact distributor) can be supplied to allow a visual representation of process variables among many other features.

Note T2550 instruments can be mounted vertically as shown in the sides of the single bay enclosure, or horizontally as shown in the two-bay version.

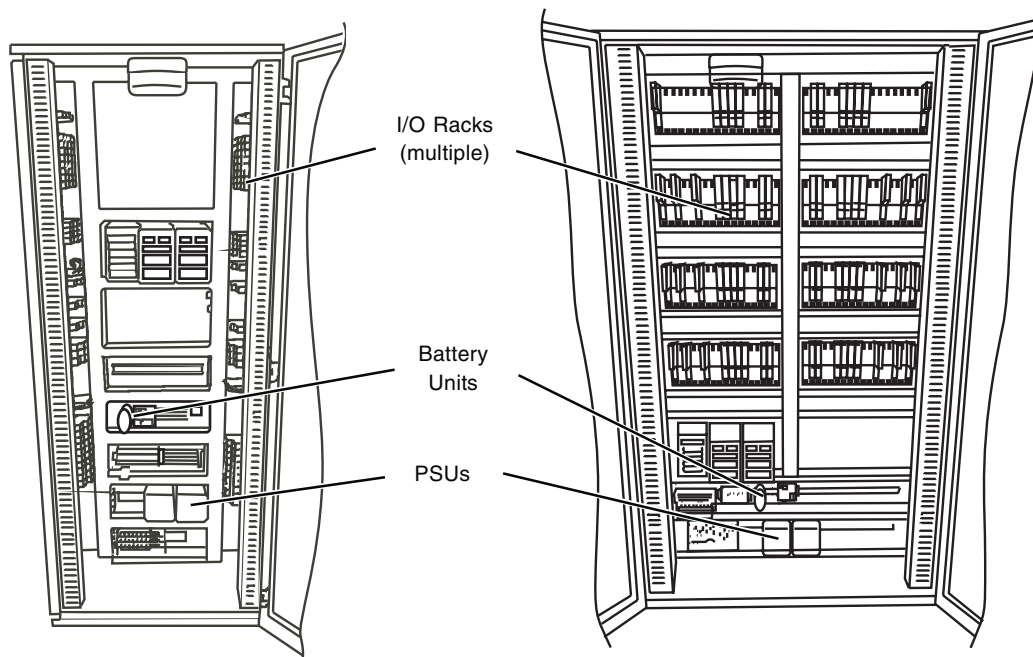

Figure 1.3.2c Typical installations

CHAPTER 2 INSTALLATION

This chapter presents safety and EMC information and describes the mechanical and electrical installation of the instrument.

The main topics covered are as follows:

- Safety and EMC information ([section 2.1](#))
- Unpacking ([section 2.2](#))
- Mechanical layout ([section 2.3](#))
- Set-up switch definition ([section 2.4](#))
- Connections and wiring ([section 2.5](#))
- Modbus communications ([section 2.6](#))
- Profibus communications ([section 2.7](#))

2.1 SAFETY AND EMC INFORMATION

Please read this section before installing the T2550 instrument.

This T2550 instrument is designed to meet the requirements of the European Directives on Safety and EMC. It is, however, the responsibility of the installer to ensure the safety and EMC compliance of any particular installation.

2.1.1 Installation requirements for EMC

This T2550 instrument conforms with the essential protection requirements of the EMC Directive 89/336/EEC, amended by 93/68/EEC. It also satisfies the emissions and immunity standards for industrial environments.

To ensure compliance with the European EMC directive certain installation precautions are necessary as follows:

- General guidance. For general guidance refer to the *EMC Installation Guide* (Part no. HA025464).
- Relay outputs. When using relay outputs it may be necessary to fit a filter suitable for suppressing conducted emissions. The filter requirements will depend on the type of load.
- Routing of wires. To minimise the pick-up of electrical noise, low voltage DC connections and sensor input wiring should be routed away from high-current power cables. Where it is impractical to do this, shielded cables should be used, with the shield grounded at both ends.
- Power supply connections. The instrument must be powered from a local power supply and must not be connected to a DC distribution network. The power supply must be earthed according to manufacturers instructions in order to give best EMC performance for the system.

2.1.2 Installation safety requirements

Caution

In order to comply with the requirements of BS EN61010, the voltage applied across I/O terminals may not exceed those terminals' isolation voltage. For terminals specified as having no isolation, the maximum permissible voltage is 30V ac or 50 V dc. Refer to individual I/O Module sections for isolation details.

PERSONNEL

Installation must ONLY be carried out by qualified personnel.

2.1.2 Installation safety requirements (Cont.)

POWER ISOLATION

The installation must include a power isolating switch or circuit breaker. This device should be in close proximity (1 meter) to the controller, within easy reach of the operator and marked as the disconnecting device for the instrument.

ENCLOSURE OF LIVE PARTS

To prevent hands or metal tools touching parts that may be electrically live, the controller must be installed in an enclosure.

BLANK TERMINAL UNIT

Base Units are supplied to hold up to 16 modules. In the event that a Base Unit is not fully populated a blank Terminal Unit, Part no. 026373, will be supplied with the system. It is important that this is fitted into the position immediately to the right of the last module in order to maintain IP20 rating.

Caution: Live sensors

The controller is designed to allow operation with the temperature sensor connected directly to an electrical heating element. However you must ensure that service personnel do not touch connections to these inputs while they are live. With a live sensor, all cables, connectors and switches for connecting the sensor must be mains rated.

CONDUCTIVE POLLUTION

Electrically conductive pollution (e.g. carbon dust, water condensation) must be excluded from the cabinet in which the controller is mounted. To secure a suitable atmosphere in conditions of conductive pollution, fit an air filter to the air intake of the cabinet. Where condensation is likely, include a thermostatically controlled heater in the cabinet.

VENTILATION

Ensure that the enclosure or cabinet housing the T2550 instrument provides adequate ventilation/heating to maintain the operating temperature of the instrument.

PRECAUTIONS AGAINST ELECTROSTATIC DISCHARGE

Caution

Circuit boards inside the instrument contain components which can be damaged by static electrical discharge. Before any circuit board is removed or handled it should be ensured that the handler, the instrument and the circuit board are all at the same potential.

2.1.3 Keeping the product safe

To maintain the units in a safe condition, observe the following instructions.

MISUSE OF EQUIPMENT

If the equipment is used in a manner not specified in this handbook or by the distributor, the protection provided by the equipment may be impaired.

SERVICE AND REPAIRS

Except for those parts detailed in the Service section, the T2550 IOC Module has no user-serviceable parts. Contact the nearest manufacturer's agent for repair.

Some Terminal Units, I/O modules (2500M), may contain fuses and must be replaced by the correct type of fuse in compliance to EN60127.

2.2 UNPACKING

The instrument and accessories should be carefully unpacked and inspected for damage. The original packing materials should be retained in case re-shipment is required. If there is evidence of shipping damage, the supplier or the carrier should be notified within 72 hours and the packaging retained for inspection by the manufacturer's and/or carrier's representative.

2.2.1 Handling precautions

Caution

Circuit boards inside the units contain components which can be damaged by static electrical discharge. Before any circuit board is removed or handled it should be ensured that the handler, the instrument and the circuit board are all at the same potential.

2.2.2 Package contents

The T2550 instrument may form part of a larger assembly, and/or may be housed in a floor or wall-mounted enclosure. If so, the documentation that accompanied those items should be referred to.

The package contents should be checked against the order codes, using the labels on the components.

PRODUCT LABELLING

Product labelling includes:





1. Sleeve label. On the outside of the T2550 IOC Module sleeves, showing the model number, serial number, and hardware build level.
2. Backplane label. On the edge of the backplane, showing the model number, serial number, and hardware build level.
3. Software labels showing version and issue numbers.
4. Compact Flash memory card label showing firmware version, issue number, initial software licence and Ethernet-Mac Address.
5. Safety earth symbol adjacent to safety earth stud.

MODULE LABELLING

All I/O modules are identified by means of labels on the side and front of the case. The side label includes details of the product code, serial number and module version.

SYMBOLS USED IN THE LABELLING

One or more of the symbols in the table below, may appear on the labelling of the unit:

Label	Function
	Caution, refer to the accompanying documents
	Functional (Ground/Safety) earth
	Protective earth terminal
	Risk of electric shock
	40 Year Environmentally Friendly Usage Period

2.3 MECHANICAL LAYOUT AND INSTALLATION

Figure 2.3.1a shows a Base Unit with the T2550R Modules and Terminal Units removed for clarity. I/O modules (refer to *I/O Module Appendix*) communicate with the T2550 IOC Modules via the internal communications bus.

Figure 2.3.1b and Figure 2.3.1c show front and side views of the T2550 IOC Modules, and Terminal Units.

The T2550 instrument can operate either independently (Simplex), or in ‘redundant’ (Duplex) mode in which case one of the T2550R Modules act as a primary, backed up by the other T2550R Module (the secondary). This can take over from the primary at any time.

When only a single T2550S module is fitted, it is recommended that the blanking plate supplied be fitted to the vacant slot, to maintain safety specifications. The Simplex T2550S module supports data in SRAM and the Real-Time Clock (RTC) for a minimum of 72 hours with an internal battery.

Note If using an external battery with the T2550R, refer to the accompanying documentation.

Power is supplied to a Duplex T2550 instrument by two external 24V (nom.) power supplies (redundant power connections). The two supplies are effectively OR'd together within the Duplex Terminal Unit, so they can run in parallel, ensuring that the T2550R modules continue to operate even if one of the supplies fails.

2.3.1 Layout drawings

Illustration Key

- (1) Retention Screws
- (2) Base Retention Clip
- (3) DIN Rail
- (4) Side Cover
- (5) Terminal Unit Retention Clip
- (6) Support for Terminal Unit
- (7) EMC Earthing
- (8) Protective Earth Terminal Strip (* - Optional)
- (9) Safety Earth connection (one per Protective Earth Terminal Strip)

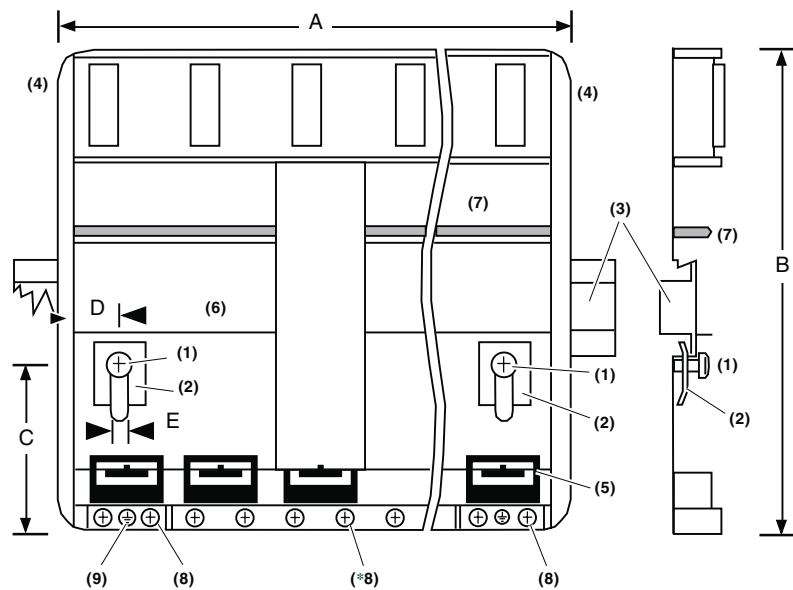

Note Always ensure a 25mm clearance for ventilation.

Figure 2.3.1a Base Unit mounted horizontally

2.3.1 Layout Drawings (Cont.)

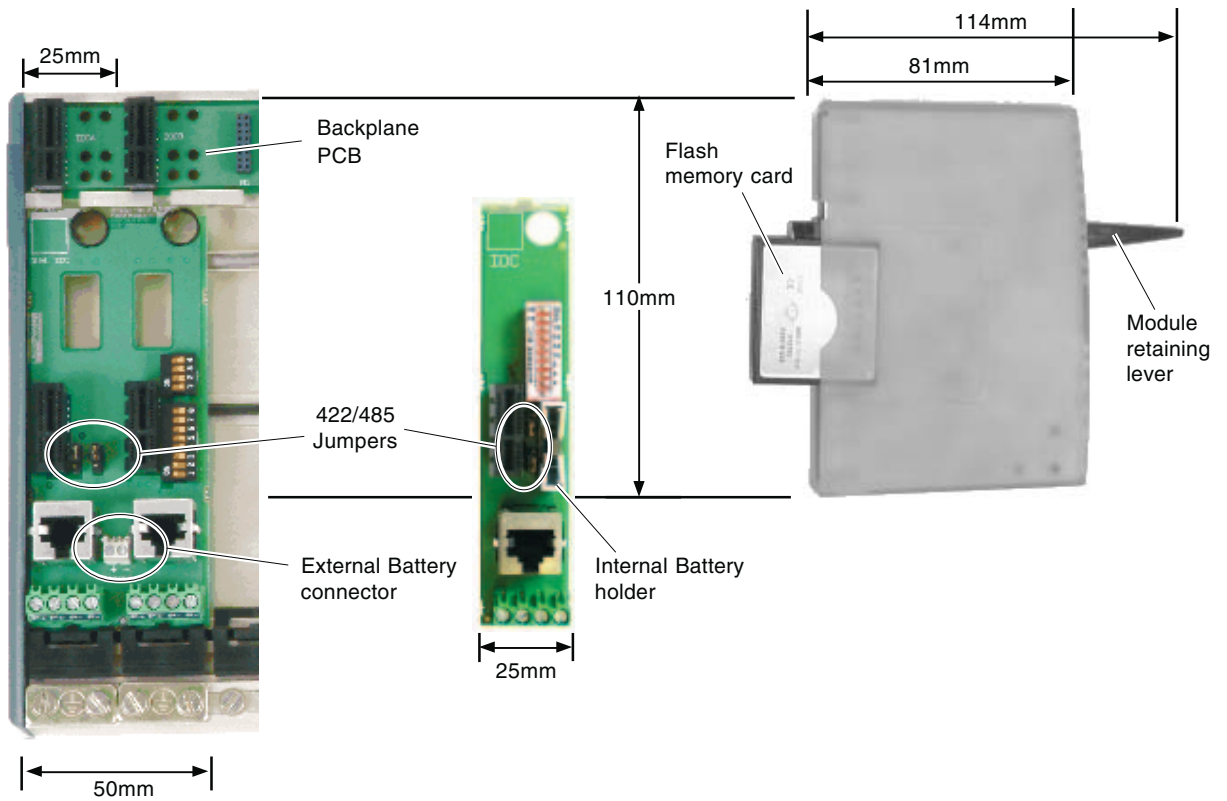

Note The dimensions shown for the Duplex Terminal Unit also apply to the Profibus Terminal Unit.

Model	Dimensions (mm)					Weight (Kg)	
	Width A	Height B	C	D	E	No Modules	All Modules
T2550B - 00S	36.0	180.0	68.0	15.0	5.0	0.6	1.0
T2550B - 04R	164.0	180.0	68.0	15.0	5.0	0.7	1.1
T2550B - 06R	214.0	180.0	68.0	15.0	5.0	0.9	1.3
T2550B - 08R	264.0	180.0	68.0	15.0	5.0	1.2	1.8
T2550B - 16R	467.0	180.0	68.0	15.0	5.0	2.5	3.0

Figure 2.3.1b Dimensions (mm)

2.3.1 Layout Drawings (Cont.)

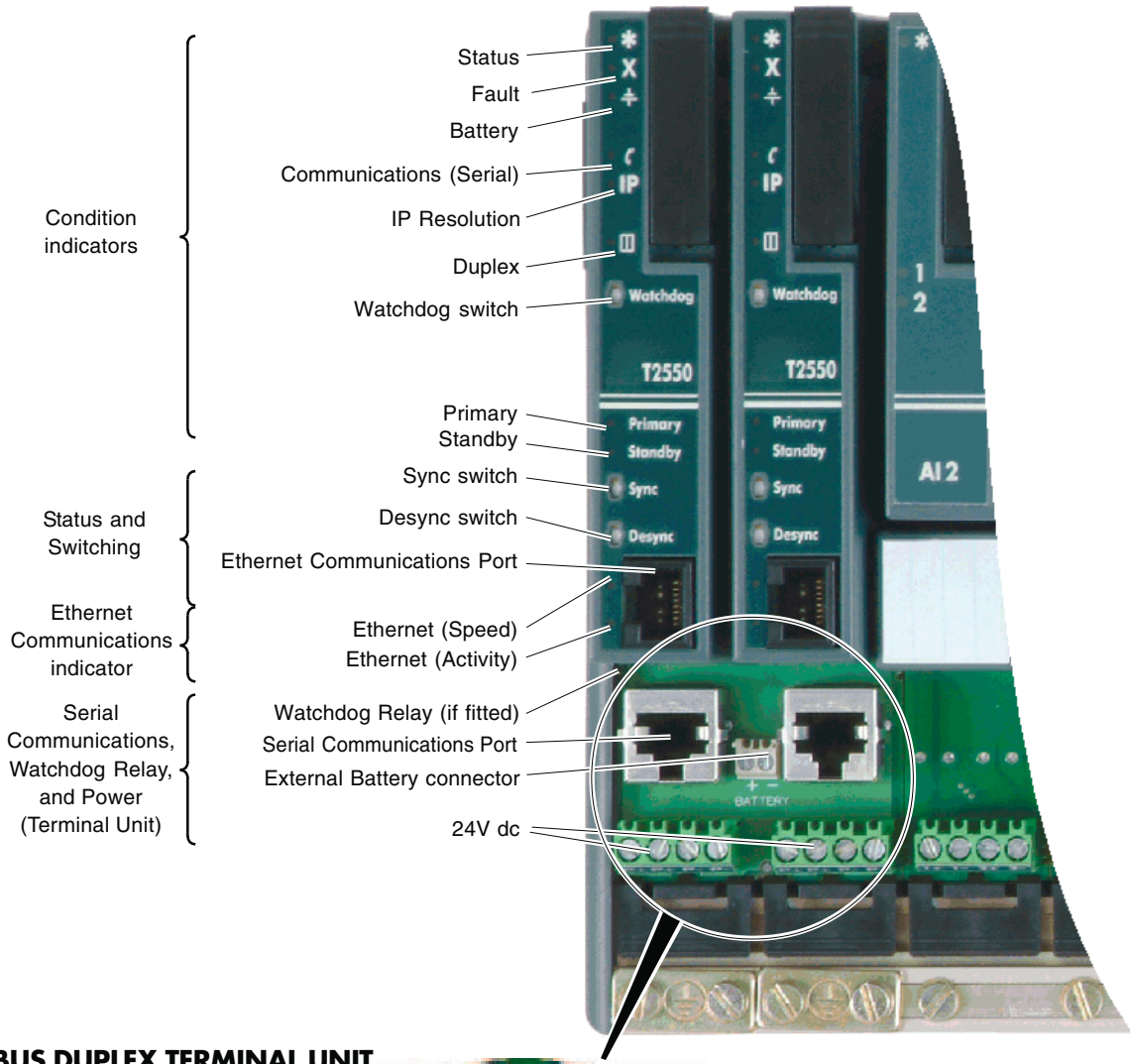

PROFIBUS DUPLEX TERMINAL UNIT

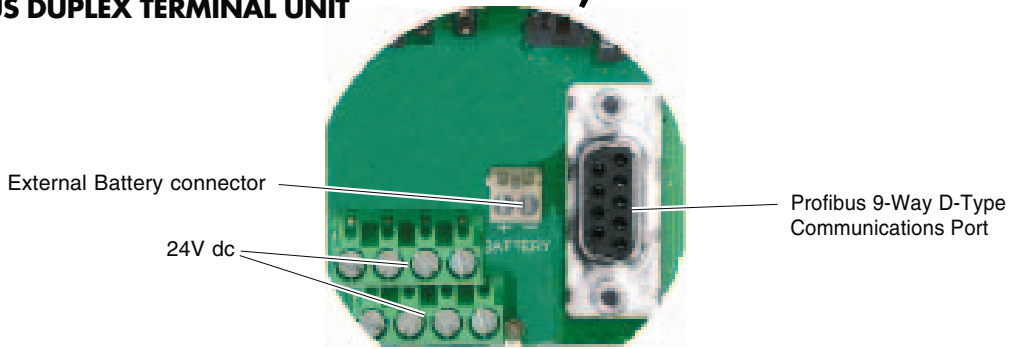

Note The Simplex Unit does not support the external battery supply, but does support battery backup via an internal battery mounted on the Simplex Terminal Unit.

Figure 2.3.1c Front panel layout (Redundant Configuration)

2.3.2 Mount a Base Unit

This Base Unit is intended to be mounted within an enclosure, or in an environment suitable for IP20 rated equipment. It can be DIN rail or bulkhead mounted.

For DIN rail mounting, use symmetrical DIN rail to EN50022-35 X 7.5 or 35 X 15 mounted horizontally or vertically.

Caution

Do not operate the equipment without a protective earth conductor connected to one of the earth terminals on the Base Unit .

The earth cable should have at least the current rating of the largest power cable used to connect to the instrument.

Connect the protective earth with a suitable tinned copper eyelet, and use the screw and washer supplied with the base unit, tightened to a torque of 1.2Nm (10.5lbin).

This connection also provides a ground for EMC purposes.

DIN RAIL MOUNTING

Note Refer to [Figure 2.3.1a](#).

Caution

It is acceptable to mount the T2550B (Base Unit) vertically up the sides of an enclosure. If it is mounted up the sides of an enclosure, it is advisable to fit a fan in the cubicle to ensure a free flow of air around the modules.

To mount on a DIN rail:

1. Mount the DIN rail, using suitable bolts.
2. Ensure that the DIN rail makes good electrical contact with the metal base of the enclosure.
3. Loosen screws (1) in the Base Unit, and allow them, and the associated Base Unit retention clips (2) to drop to the bottom of the screw slot.
4. In the back of the Base Unit is an extruded slot which locates with the DIN rail (3).
5. Fit the top edge of this into the top edge of the DIN rail (3)
6. Slide the screws (1) with the associated clips (2) upwards as far as they will go towards the top of the screw slots. The angled edge of the base retaining clip (2) must locate behind the bottom edge of the DIN rail.
7. Tighten the screws (1).

DIRECT PANEL MOUNTING

To mount direct on the bulkhead:

1. Remove the screws (1) and base retention clips (2).
 2. Hold the Base Unit horizontally or vertically on the panel and mark the position of the two holes on the panel.
 3. Drill two 5.2 mm holes in the panel.
 4. Using M5 bolts supplied, secure the Base Unit to the metal panel.
-

Caution

If a bolt other than the one supplied is used, the depth of the bolt head should not exceed 5mm. This is to ensure that there is sufficient isolation between the bolt head and any module mounted above it which is connected to 230V.

2.3.3 Fit a Terminal Unit

It is recommended that power be isolated, before the Terminal Unit is removed from the Base Unit.

Note This procedure is identical for all Terminal Units .

To fit a Terminal Unit:

1. Locate the tag on the Terminal Unit printed circuit board with slot in Base Unit.
2. Press the bottom of the Terminal Unit to secure it in place, confirmed by a 'click' as the retention clip springs back into position. Wiring of the T2550 instrument can take place with only the Terminal Units fitted or after the modules have been fitted, as preferred. Wiring is described in following chapters.

Notes

- 1 *In Redundant operation the two left-hand positions are always reserved for the T2550R modules, and is identified by the larger connector on the Backplane interconnection bus.*
- 2 *All other Terminal Units can be fitted in any other position on the Base Unit.*
- 3 *In the event that the Base Unit is not fully populated a blank Terminal Unit must be fitted, Part no. 026373. To maintain IP20 rating it is important that this blank Terminal Unit is mounted immediately to the right of the final module position.*

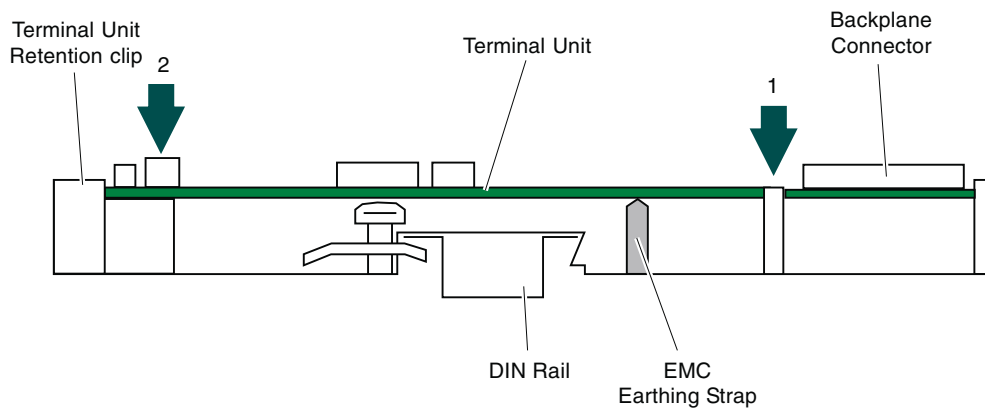

Figure 2.3.3 Fitting a Terminal Unit (Side View)

To remove a Terminal Unit:

1. Remove the I/O module, if fitted.
2. If required, remove all relevant wiring to the Terminal Unit.
3. Press the Retention clip at the bottom of the Terminal Unit.
4. Carefully remove the Terminal Unit from the Base Unit.

ISOLATOR LINKS AND FUSES (OPTIONAL FOR I/O TERMINAL UNITS ONLY)

Up to four isolator links or fuses are available as options for certain I/O modules.

Isolator links disconnect plant connections from the module (for testing and commissioning).

If isolator links or fuses are not fitted then a dummy fuse cover is fitted.

2.3.4 Fit a Module

Modules may be changed on a live system, in which case the following recommendations apply:

- To avoid indeterminate readings when changing an input module, use the configuration tools to place the relevant channel blocks in 'MANUAL' Mode before the module is removed.
- To prolong the life of the connectors, remove any external power before an output module is removed.

Note The following procedure is identical for ALL modules.

To fit a Module:

1. Pull the Module retaining lever forwards into the unlocked position (🔓), as shown in Figure 2.3.4.
2. Line up the Module in the correct Terminal Unit and slide into place using the Plant/Process connection case as guides as appropriate. The plugs on the module should align with the sockets on the Terminal Unit and module interconnection bus. The module retaining clip should align with the corresponding hole in the Terminal Unit.

Note A polarising key is provided on the module which is designed to prevent a module from being inserted into the incorrect Terminal unit.

3. When the module is correctly aligned, push the module retaining lever back to lock (🔒) the module into place. Wiring of the instrument can take place with only the Terminal Units fitted or after the modules have been fitted, as preferred. Wiring is described in following chapters.

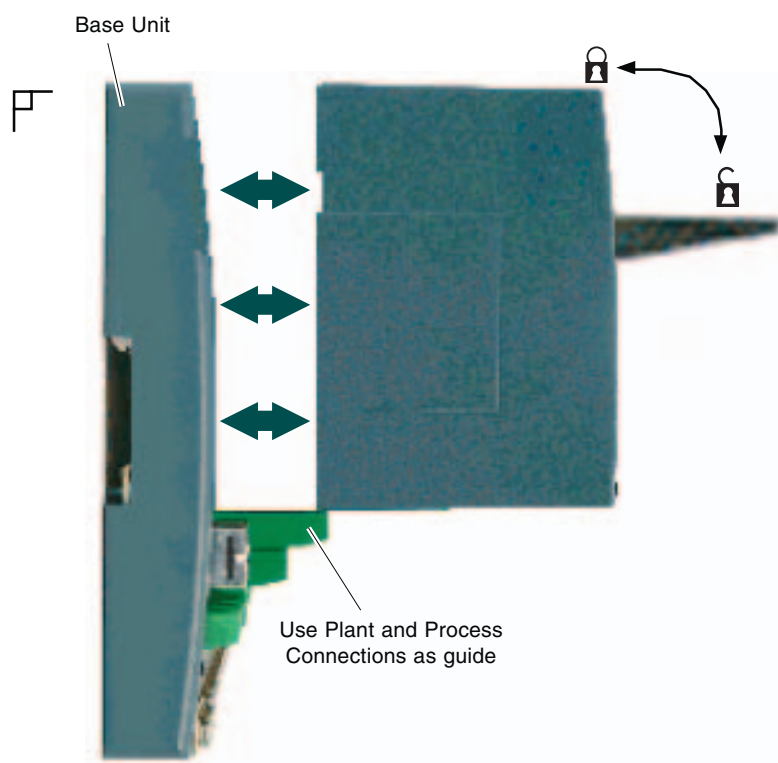

Figure 2.3.4 Module fitting/removal

To remove a Module:

1. Pull the Module retaining lever forwards into the unlocked position (🔓), as shown below.
2. Carefully withdraw and remove the module from the Terminal Unit using the Plant and Process connection casing as a guide as appropriate.

2.3.5 Setting the IP Address

Note For a more comprehensive description of IP Addresses, refer to the ELIN User Guide (Part no. HA082429) for details.

An instrument (IP host) will always need an IP Address, this can be allocated either automatically or manually. Which method (and the allocated IP Address used) will depend on any existing (or planned) networks.

Each instrument uses a one-to-one mapping of, LIN Node Number to a single IP Address, defined in the 'network.unh' file.

IP ADDRESS

ELIN runs over Ethernet using IP (Internet Protocol). Instruments (IP hosts) are identified by an 'IP Address',

- Expressed in 'dotted decimal' notation

Example 192.168.111.222

- Actually represents a 4 byte (32-bit) number

Example 0xC0 A8 6F DE

PORT NUMBER

By default, all ELIN instruments automatically use Port Number 49152.

Note For a more comprehensive description of Port Numbers, refer to the ELIN User Guide (Part no. HA08242) for details.

ALLOCATION OF IP ADDRESS

DHCP

This is a method whereby the instrument (IP host) will ask a DHCP server to provide it with an IP Address. Typically this happens at start-up, but can be repeated during operation. DHCP includes the concept of 'leases' (i.e. the assigned value will 'expire').

A DHCP server is required that can respond to the request. The DHCP server will need to be configured to correctly respond to the request. This configuration will depend on the company network policy.

Link-Local

Link-Local is used as a fallback to either DHCP or BootP, or can be used on its own as the only IP Address configuration method. Link-Local will always assign an IP Address in the range 169.254.X.Y. This IP Address range is reserved for use by Link-Local and is explicitly defined as private and non-routable.

The Link-Local algorithm ensures that an instrument (IP host) on a network will chose a unique IP Address from the Link-Local range.

This is supported by Windows 98 and onwards, and was originally specified as a fallback from DHCP.

Manual

The IP Address is explicitly defined in the 'network.unh' file.

BootP

BootP or Bootstrap Protocol (Internet (TCP/IP protocol)) is used by a network computer to obtain an IP Address and other network information such as server address and Default Gateway. Upon startup, the client station sends out a BOOTP request to the BOOTP server, which returns the required information. A BootP timeout period can be configured. If this period elapses before the IP Address, Subnet mask, and Default Gateway address are obtained, the values will automatically reset to 0.0.0.0.

2.3.5 Setting the IP Address (Cont.)

EDITING THE NETWORK SETTINGS

Each instrument uses a one-to-one mapping of, LIN Node Number to a single IP Address, defined in the Instrument Properties dialog.

Note The Compact Flash card is accessed using a standard Compact Flash card reader. The 'network.unh' file **MUST** be edited using the Instrument Properties dialog. It can be edited using a text editor program, e.g. 'notepad.exe', but this is not recommended.

When despatched from the factory, the instrument is configured using DHCP with Link-Local Fallback, and a default LIN Protocol Name, 'NET'.

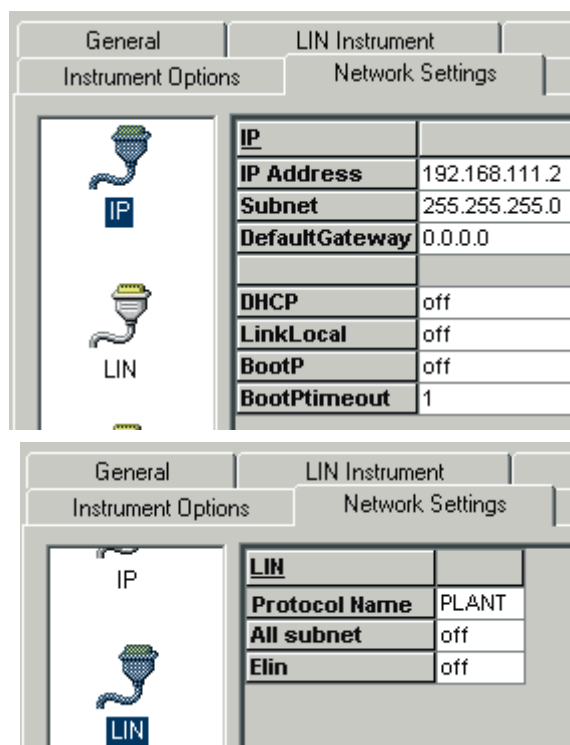

However, if the instrument is to have a fixed IP Address, i.e. 192.168.111.2, and use the LIN Protocol Name, 'PLANT', the Instrument Properties dialog must be used to modify these parameters.

Note The IP Address must correspond to the local company Network Policy.

To display the Instrument Properties dialog, select the **Properties** command after selecting the Instrument Folder in an appropriate Explorer view.

When the applicable parameters have been edited, the operation of the 'OK' button will display a request to update the Instrument parameters.

Note When connected to a T820 via Serial communications, the Instrument Options, COM port Protocol field **MUST** be set to Panel820.

RECOVERY FROM UNKNOWN IP ADDRESS CONFIGURATION

To reset the IP Address, and Subnet Mask (255.255.255.0) of an Instrument with an unknown IP Address when a Compact Flash card reader is not available, set the LIN Address switches as denoted below.

IOC Unit	LIN Address Switches	In Position	For IP Address
Simplex Unit	ALL (SW1:S1 to SW1:S8)	OFF	192.168.111.222
Duplex Unit			
Simplex Mode	ALL (SW1:S1 to SW1:S8)	OFF	192.168.111.222
Duplex Mode	ALL (SW1:S1 to SW1:S8)	ON	Left - 192.168.111.222 Right - 192.168.111.223

A Computer with a fixed IP Address on this Subnet can then be connected directly to the instrument and used to inspect and edit the IP Address of the IOC module.

Note In this instance only, the Terminal Configurator **MUST** be used to edit an IP Address, see Terminal Configurator. However, in all other circumstances the Instrument Properties dialog should be used.

To change an IP Address using the Terminal Configurator, start a Telnet session and define the connections settings, see Terminal Configurator. Once the settings are configured, connect to the required instrument and access the Initial menu. After selecting the **Database** option, choose the **Utilities** command and then the **ELIN** option. This will show the ELIN Setup page, used to edit and inspect the LIN parameters of the connected instrument.

2.4 TERMINAL UNIT SWITCHES

2.4.1 Switch Location

The Terminal Unit switches and links for setting communications addresses and for selecting options on and off are revealed (Figure 2.4.1) when the T2550R modules or the cover plate is removed from the Terminal Unit.

2.4.2 Switch and Link functions

LIN ADDRESS SETTING SWITCH

Figure 2.4.2a below shows the LIN address setting switch, SW1, (located on the Terminal Unit as shown in Figure 2.4.1). The figure shows a sample set up for address pair 7A/7B.

In a Simplex (T2550S) configuration, the cold start primary always adopts the left-hand position in the Base Unit (even address).

Note A second module is not supported in a Simplex configuration.

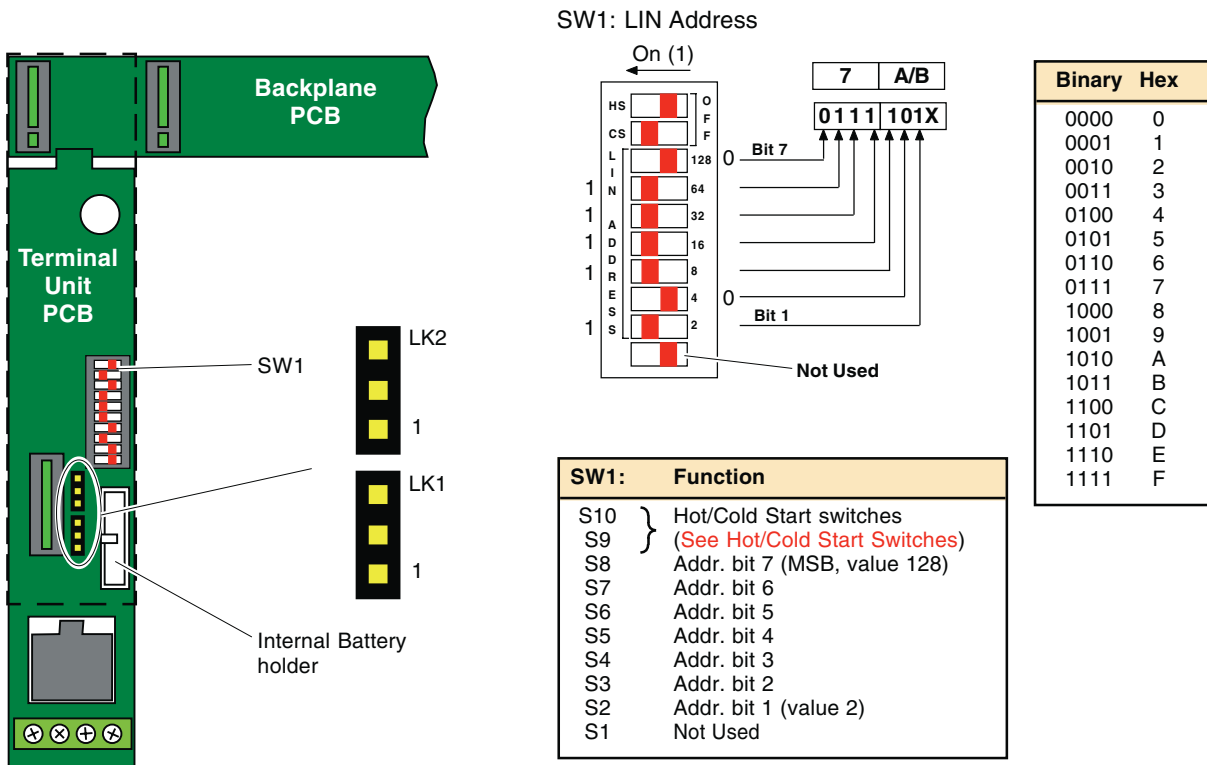

Caution
Addresses 00, FE and FF are reserved, do NOT use.

Figure 2.4.1a Location of Simplex Terminal Unit switches

2.4.2 Switch and Link functions (Cont.)

When working in a Redundant configuration, the primary (cold start primary) is initially the left-hand position (even address) and the secondary (cold start secondary) is initially the right-hand position (odd address) in the Base Unit. Should it prove necessary for the secondary to changeover and become the primary, it will also take over the even address.

Example of how to set LIN address 7A/7B

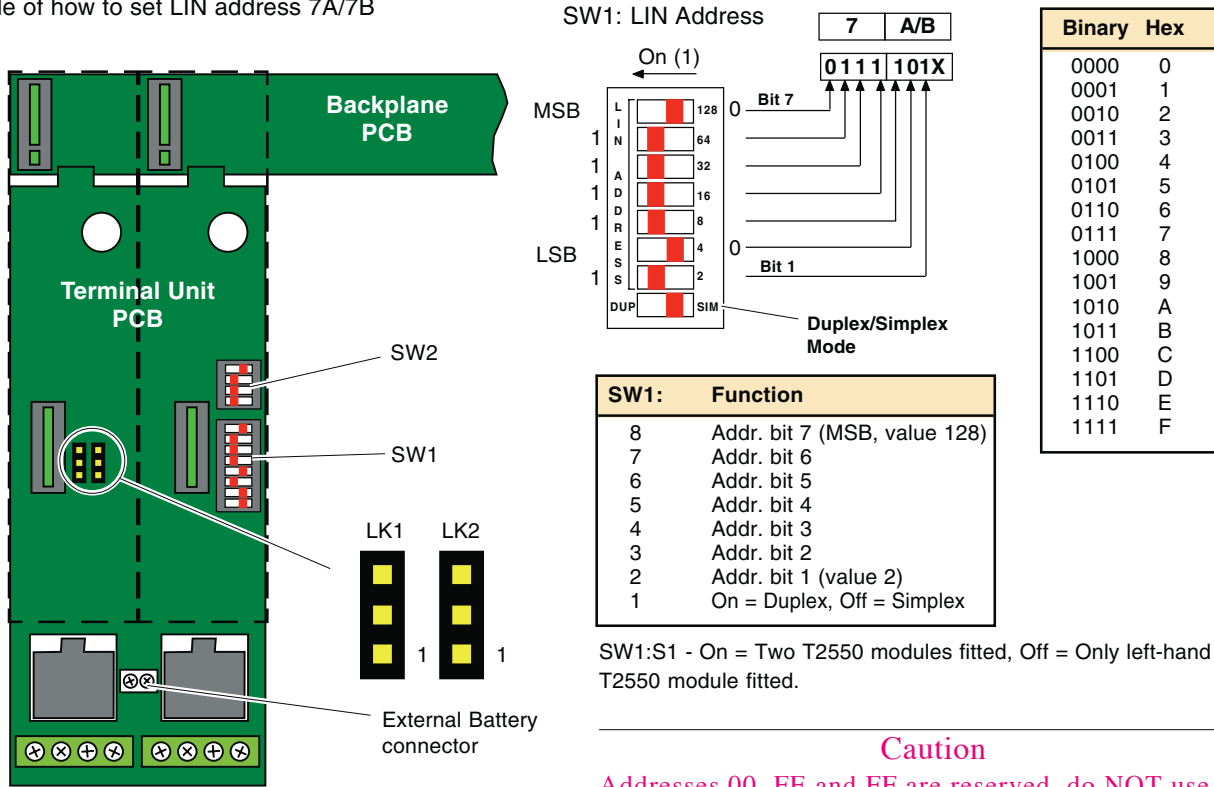

Figure 2.4.1b Location of Duplex Terminal Unit switches

Figure 2.4.2a LIN address setup example

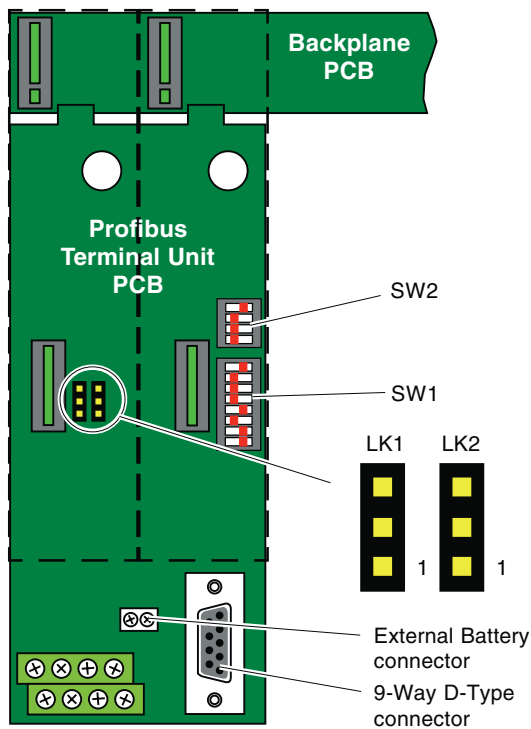

Figure 2.4.1c Location of Profibus Duplex Terminal Unit switches

2.4.2 Switch and Link functions (Cont.)

LIN OPTIONS SWITCH

Figure 2.4.2b, below, shows the Options switch located on the Terminal Unit as shown in Figure 2.4.1, Duplex Unit - SW2, Simplex Unit - SW1:S9 and SW1:S10.

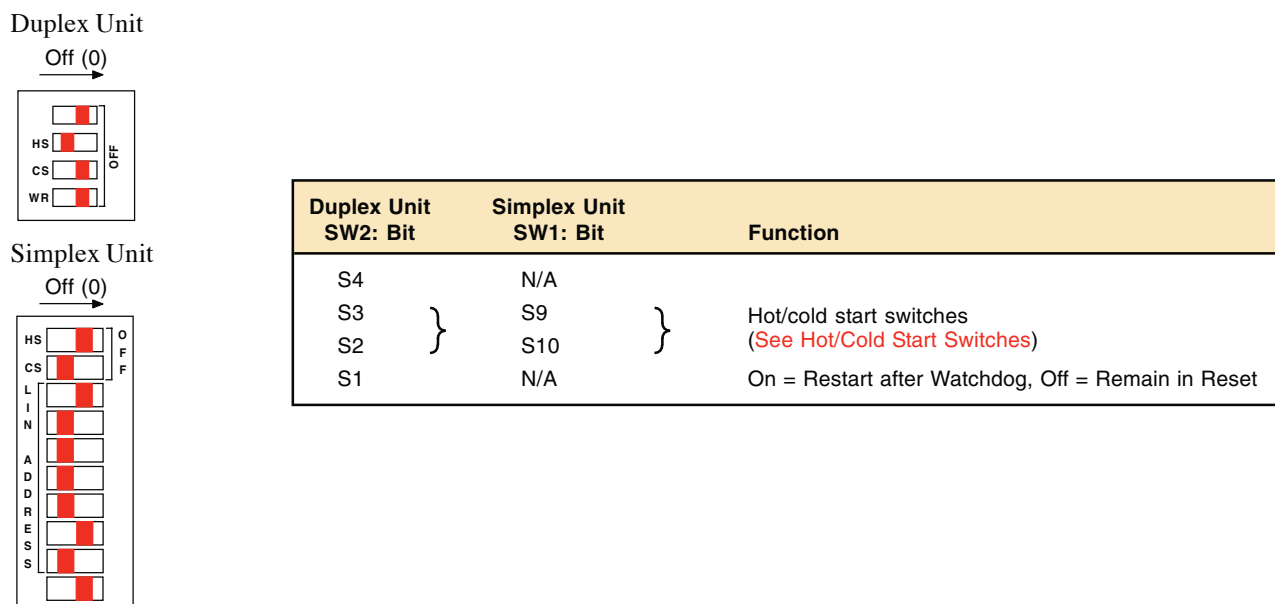

Figure 2.4.2b Options switches setup

Watchdog Retry (Duplex Unit - SW2:S1, Simplex Unit - Not Applicable)

Setting this switch segment (SW2:S1) 'on' (slide to the left) causes the T2550R module to try to start again after any watchdog failure. Setting the segment 'off' (slide to the right) disables the retry and the T2550R module will need manual restart after a watchdog failure.

Hot/Cold Start (Duplex Unit - SW2:S2 and SW2:S3, Simplex Unit SW1:S9 and SW1:S10)

Setting these switch segments in the appropriate combination will define how the T2550 IOC module attempts to start (see below).

Duplex Unit SW2:S2 Bit 2	Duplex Unit SW2:S3 Bit 3	Simplex Unit SW1:S9 Bit 9	Simplex Unit SW1:S10 Bit 10	Function
Off	Off	Off	Off	Automatically generate a LIN Database.
On	Off	On	Off	Attempt to cold start, halt if unsuccessful.
Off	On	Off	On	Attempt to hot start, halt if unsuccessful.
On	On	On	On	Attempt to hot start, if unsuccessful attempt to cold start, halt if unsuccessful.

- An automatically generated LIN Database is created when the instrument is powered up with both these switch segments set OFF, see Automatic I/O Build section.
- Cold start is an attempt to start the instrument using the previously loaded database, but with parameters and values set to starting values appropriate to the process.
- Hot Start is an attempt to start the instrument from where it stopped running.
- Hot/Cold start is an attempt to start the instrument from where it stopped running, however if this fails the Cold start is attempted.

Note Any unsuccessful start-up sequence will halt the T2550 instrument.

2.4.2 Switch and Link functions (Cont.)

LINKS

Below is a representation of the Links located on the Terminal Unit as shown in [Figure 2.4.1](#), above.

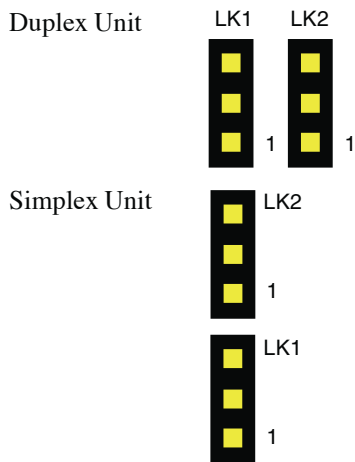

Link	Position	Function
Ethernet Terminal Unit		
LK1 and LK2	1-2	RS485 3-wire Modbus communications.
LK1 and LK2	2-3	RS485 5-wire Modbus communications.
<i>Note Modbus communications via the Ethernet can be configured using the Instrument Properties dialog, see Instrument Properties help (Part no. HA029278).</i>		
Profibus Terminal Unit		
LK1 and LK2	1-2	Profibus Network Terminated.
LK1 and LK2	2-3	Profibus Network Unterminated.
<i>Note The Links are used to terminate the Profibus network and must be fitted to the devices on either end only.</i>		

2.5 CONNECTIONS AND WIRING

T2550 Instruments may be supplied mounted in an enclosure, together with the appropriate termination assemblies, either fitted in the enclosure or supplied in kit form. Please refer to the documentation that was supplied with the enclosure for details of the connections and wiring.

If you are assembling the system yourself, refer to the *I/O Modules Appendix*, or the *Installation and Wiring Sheet* (Part no. HA028901) supplied with the instrument, the *LIN/ALIN/ELIN Installation & User Guide* (Part no. HA082429U005), the *ELIN User Guide* (Part no. HA082429) and the *Communications Manual* (Part no. HA028014) for advice on connections and wiring to the I/O modules.

Figure 2.5a and Figure 2.5b below show simplified overall connection diagram for a Simplex or Duplex control system using an Ethernet hub/switch. Category 5 cables may be used for individual line lengths of up to 100 metres. For line lengths greater than this one or more pairs of hubs with fibre-optic connections is recommended.

Note Profibus Communications is supported using the dedicated Profibus Terminal Unit and IOC module.

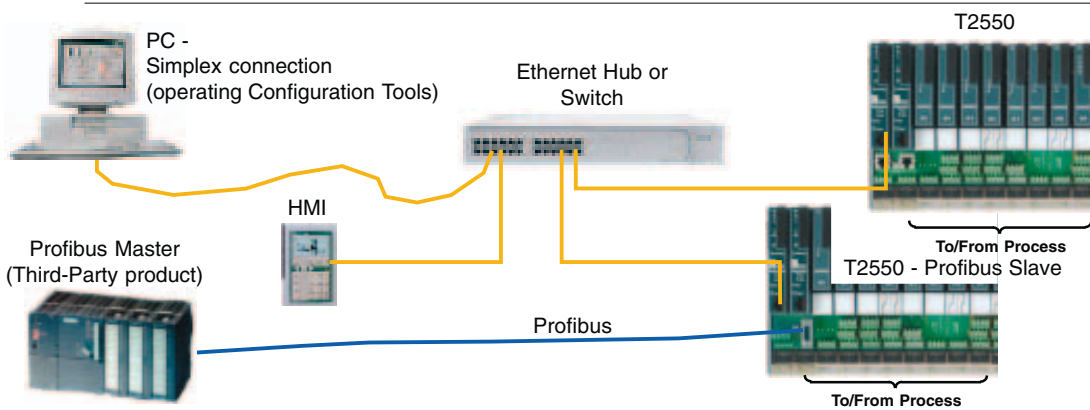

Figure 2.5a Typical overall Simplex connection diagram

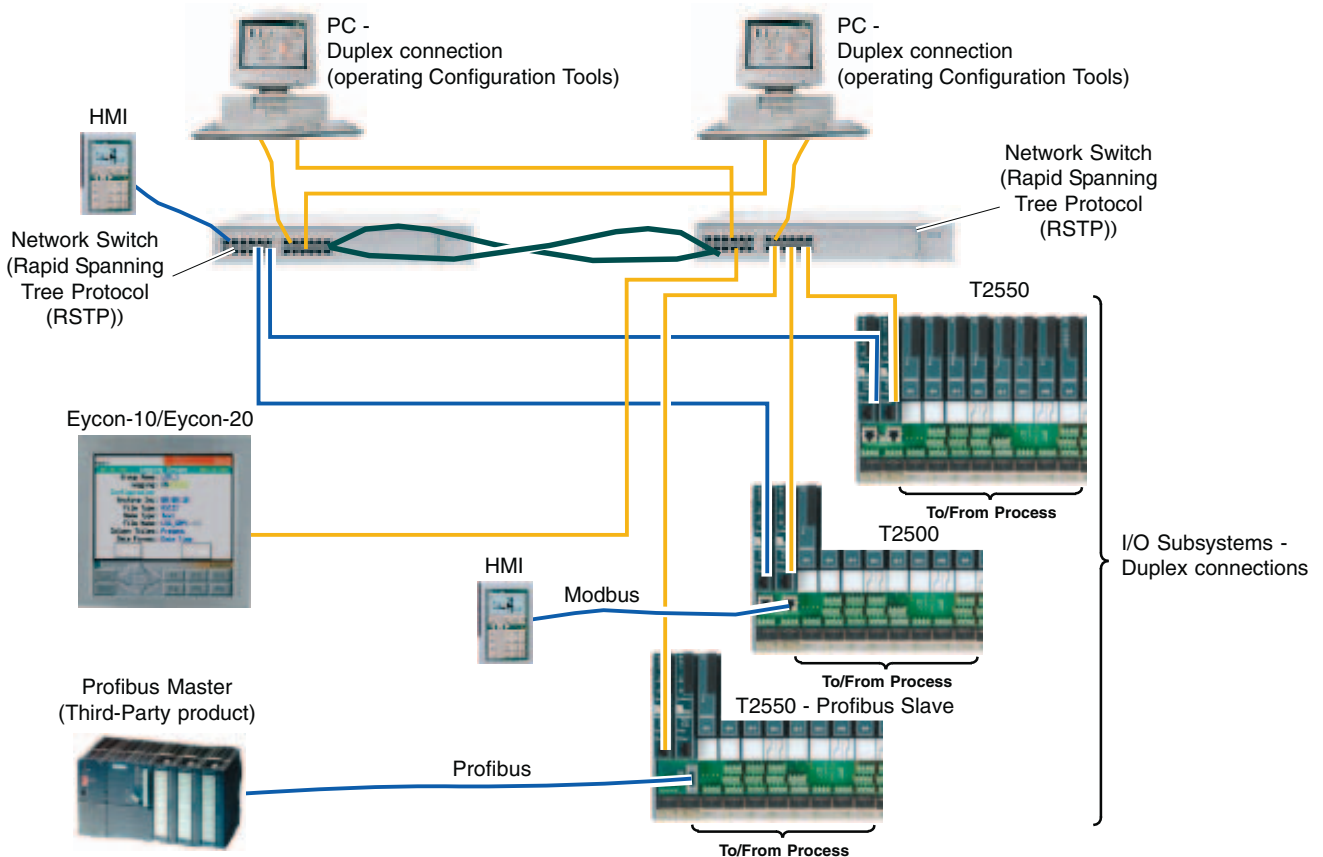

Figure 2.5b Typical overall Duplex connection diagram

2.5.1 Communications

The RJ45 connector on the T2550 IOC Module is designed for Ethernet LIN network (ELIN), whereas the RJ45 connector on the Terminal Unit supports Serial communications. The dedicated Profibus Terminal Unit provides a 9-Way D-Type connector to support Profibus communications.

The Ethernet RJ45 connectors on the T2550 IOC Module support Modbus-TCP Communications with optional master and slave, simultaneously with the ELIN Communications.

The Profibus 9-Way D-Type connector on the T2550 IOC Module support Profibus Communications as a Profibus Slave only, simultaneously with the ELIN Communications.

DUPLEX ETHERNET UNIT

DUPLEX PROFIBUS UNIT

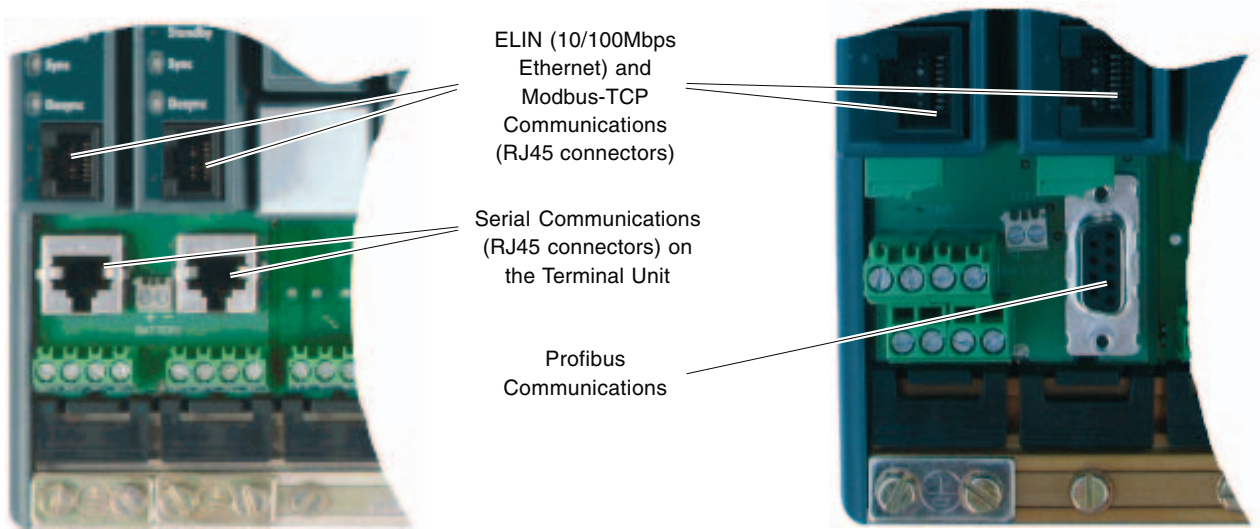

Figure 2.5.1a Communication ports

ELIN CONNECTORS

Each T2550 IOC Module contains a 10/100base T port for Ethernet communications via a standard RJ45 type connector.

Connection with an Ethernet hub/switch is made using a Category 5 RJ45-to-RJ45 cable assembly. When connecting to the Ethernet hub/switch, a ‘straight-through’ cable is used. When connecting directly to another device supporting 10/100base T Ethernet, a ‘cross-over’ cable is required. Figure 2.5.1b shows the RJ45 pinout connections.

ETHERNET AND MODBUS-TCP COMMUNICATIONS

Figure 2.5.1b and [Figure 2.5.1c](#) show the connector pinouts for the Ethernet communications.

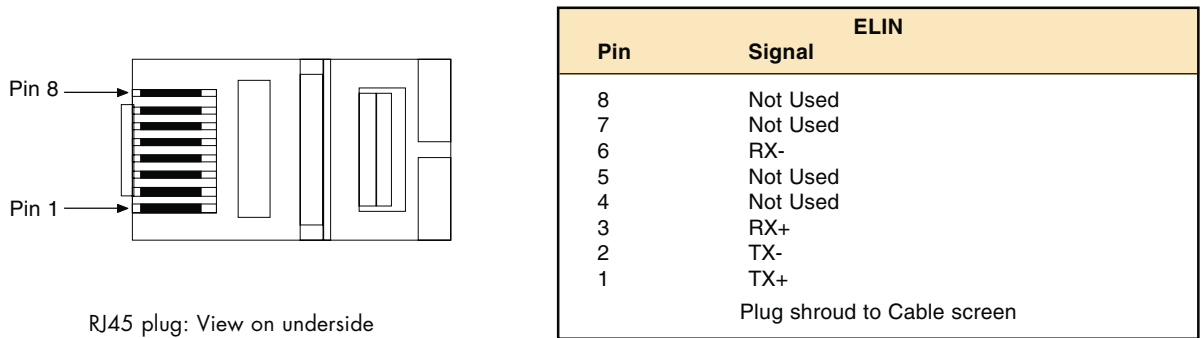

Note Modbus-TCP Communications will be supported using these pinouts.

Figure 2.5.1b Ethernet Pinouts for RJ45 type plugs

2.5.1 Communications (Cont.)

ETHERNET HUBS/SWITCH

The use of standard industrial ‘off-the-shelf’ Ethernet switch is recommended, using ‘Straight-through’ cables (Figure 2.5.1c). For further details, the *LIN/ALIN Installation and User Guide* (Part no. HA082429U005) should be referred to.

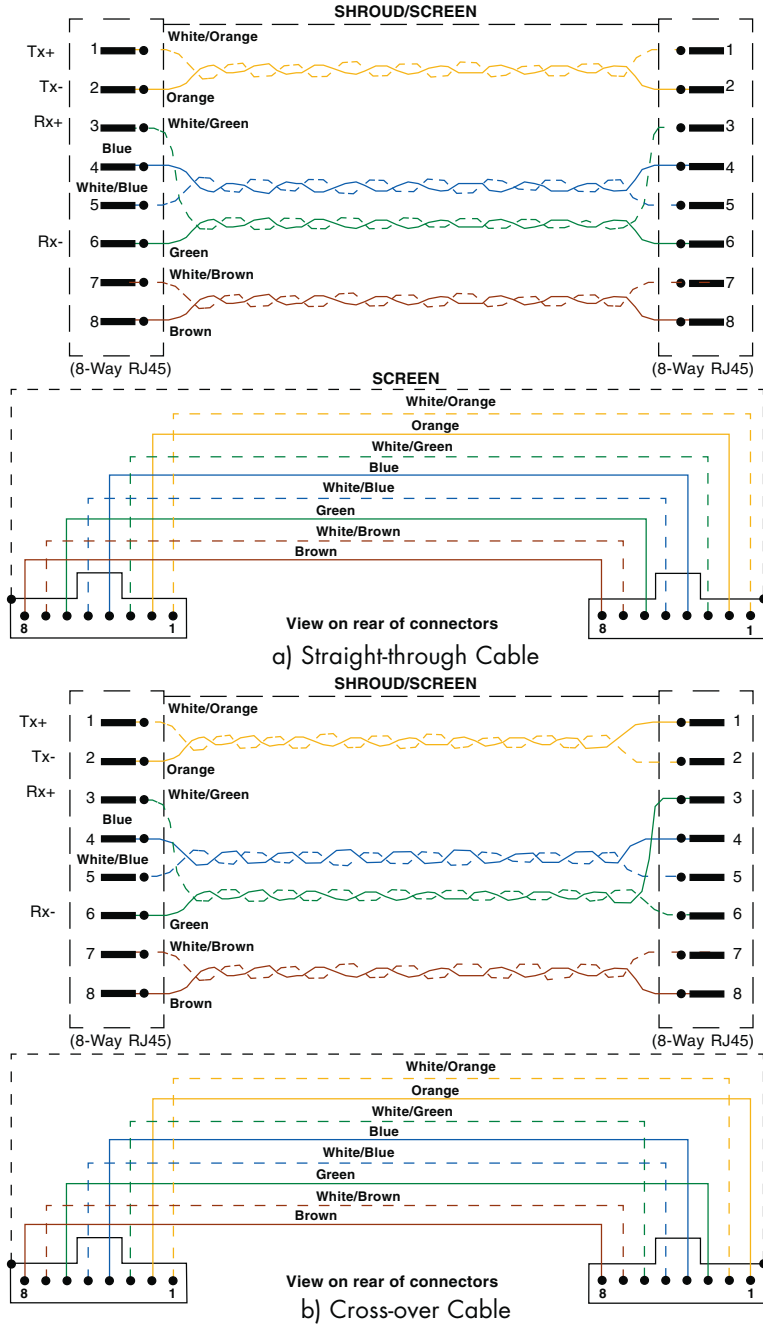

Figure 2.5.1c ELIN connection details

CABLING

Shielded RJ45 connectors and screened Category 5 cables are widely available, however, specifications vary and not all components may be suitable for reliable operation. In view of the problems that can arise with inadequate cabling, it is strongly recommended that ready-made interconnecting cables are ordered from the manufacturer.

Note The Profibus Terminal Units supports ‘Line A’ and ‘Line B’ Profibus cable types, see Communications Manual (Part no. HA028014).

2.5.1 Communications (Cont.)

SERIAL CONNECTORS

Each Terminal Unit contains RS485 RJ45 connector(s) for Serial communications.

- A single connector on the Simplex Terminal Unit.
- Two connectors on the Duplex Terminal Unit.

The Serial connection may be used to connect to an operator interface unit, create a Modbus network or communicate with a variety of third-party serial devices. Figure 2.5.1d shows the RS485 RJ45 pinout connections.

Figure 2.5.1d shows the connector pinouts for Serial communications. These must be configured in conjunction with the Links (LK1 and LK2).

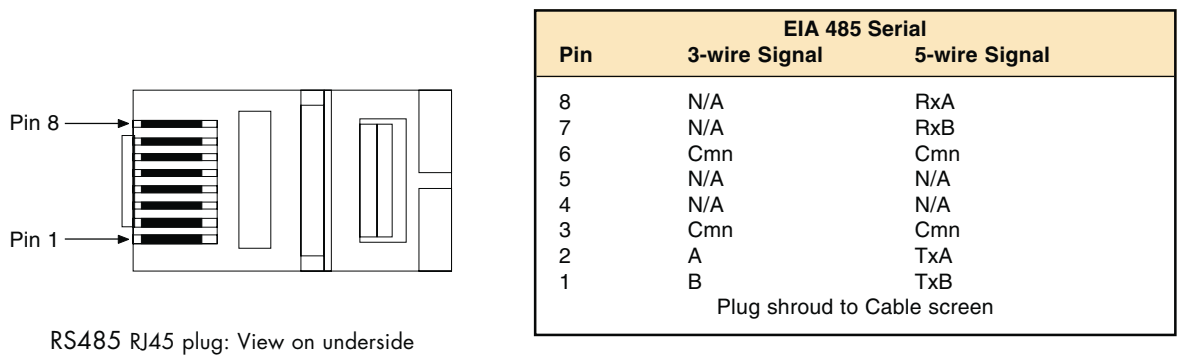
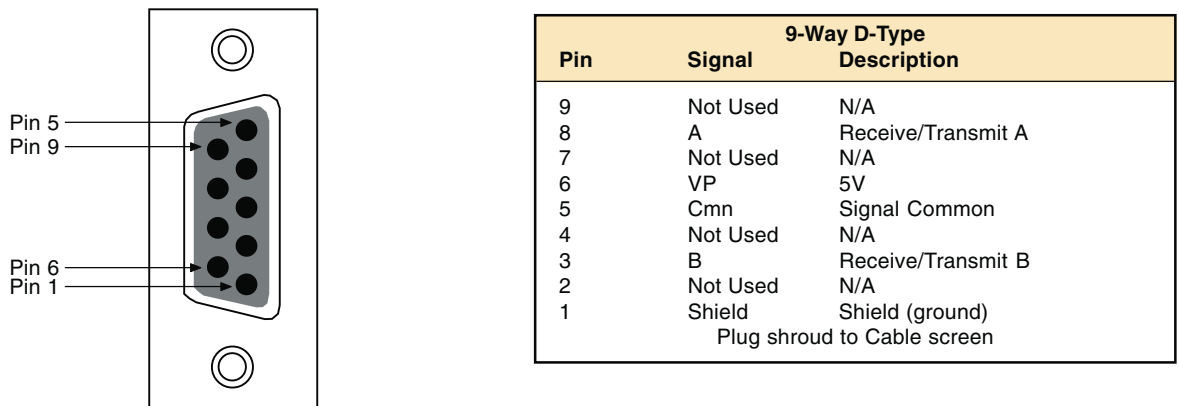

Figure 2.5.1d Modbus Pinouts for T2550 module RS485 RJ45 type plugs

PROFIBUS CONNECTORS

The Profibus Terminal Unit is dedicated to Profibus communications via the single 9-Way D-Type connector. The Links are used to terminate the Profibus Network and MUST be fitted to the devices on either end only. All other switches, connectors and links are identical to the Duplex Terminal Unit, including the power supply connections that are fitted to the lower left of the Profibus Terminal Unit.

Figure 2.5.1e shows the connector pinouts for Profibus communications.



Female 9-Way D-Type: View on Profibus Terminal Unit

Figure 2.5.1e Profibus Pinouts for T2550 module 9-Way D-Type connectors

2.5.2 Configuration Tools

CONFIGURATION OF CONTROL STRATEGIES AND SEQUENCES

Each T2550 IOC Module contains an RS485 RJ45 Ethernet socket allowing on-line monitoring and configuration editing using LINtools (the recommended configuration tool), or the simpler inbuilt Configurator via the Ethernet network. To automatically generate a LIN Database from existing hardware use the Automatic I/O Build capability.

LINtools and the Terminal Configurator

The Strategy and the sequences to be run in the T2550 instrument may be configured and downloaded using the external PC-based graphical software package, LINtools, which is fully described in the *LINtools Help* (Part no. RM263001U055) or with the simpler inbuilt Configurator and a dumb terminal, Terminal Configurator. In both scenarios the *LIN Block Reference Manual* (Part no. HA082375U003) should be consulted for details of the function blocks.

Note It is possible to configure a whole system using the Terminal Configurator, but is not recommended because of the complexity of most systems.

LINtools RESTRICTIONS

The use of LINtools is restricted only by the requirement of a Project folder containing appropriate Network and Instrument folders. The creation of these folders assist LINtools with the management of the control strategy, that ensures the Workspace is easy to use.

A New Project folder is created via the  Start > Program > ... > New Project, and thereafter using the context-sensitive menus to create the required Network and Instrument folders. For more information see *Configuration* section.

Note '...' indicates the file path of the installed software.

Terminal Configurator RESTRICTIONS

The use of the Configurator is restricted according to the operating mode of the T2550 IOC Module in the following ways:

- It can only be used on the current primary module.
- The LIN Database must not be running if you want the full capability to create function blocks, LIN Databases, edit function block field values, and modify pool data (e.g. engineering units). If it is running, the Configurator can write only to the normally runtime-writeable fields, e.g. block names cannot be edited, but new function blocks may be added and new 'wires' can be made on-line. However this is only allowed if the secondary is unsynchronised. When editing the LIN Database is complete it must be saved, and then the T2550 IOC Module re-synchronised.

Note These restrictions prevent files or edits occurring in the primary LIN Database that cannot be tracked by the secondary LIN Database.

Automatic I/O Build (See *Automatic I/O Build* section)

With the correct Options Switch configuration, see [Hot/Cold Start Switches](#), a simple LIN Database including appropriate I/O channel blocks is created in memory. Before editing the LIN Database can commence it must be stopped if currently running, and saved, requiring it to be named. If wishing to edit the LIN Database using LINtools it can be uploaded in to the LINtools software as a Function Block List.

Note Use the LINtools software package to open the '*.dbf'. Additional commands can be used to generate the finished Function Block Diagram.

2.5.3 Power

DC SUPPLY WIRING

Each T2550 IOC Module supports 24V supply. The Simplex Unit has only one 24V supply connection at the bottom of the Terminal Unit to permit 24V power supply, whereas the Duplex Unit has two, this permits 24V power supply redundancy. The T2550 instrument will operate on any dc voltage between 18V and 30V at a maximum power requirement of 50W per T2550 IOC Module.

Note The Duplex T2550R also has an additional connector to allow an external battery of between 2.5V and 3.5V to be connected to maintain the Real-Time Clock (RTC). Typical drain currents are <0.1 mA.

A Lithium Maganese Dioxide battery is supplied on the Simplex Terminal Unit. When fully charged this will maintain the Real-Time Clock (RTC) data for a minimum of 72 hours. If the T2550 IOC Module is removed from the Terminal Unit the Real-Time Clock data is retained for a maximum of one hour via an internal super capacitor.

Figure 2.5.3 shows the locations of the connectors and gives recommended conductor sizes based on current carrying capability and connector capacity.

Caution

- 1 Neither the positive nor the negative supply line may exceed 40V peak, with respect to Safety Earth potential.
- 2 Should the supply voltage fall below 18 Volts during startup (caused, for example by current limiting on the Power supply unit), the instrument will fail to start successfully. It will then attempt to restart, and enter a repeating cycle.

FUSES

All positive supply lines must incorporate a fuse. Suitable types are 4A Type T for 24 Volt supplies and 0.5A Type T for each external battery fitted.

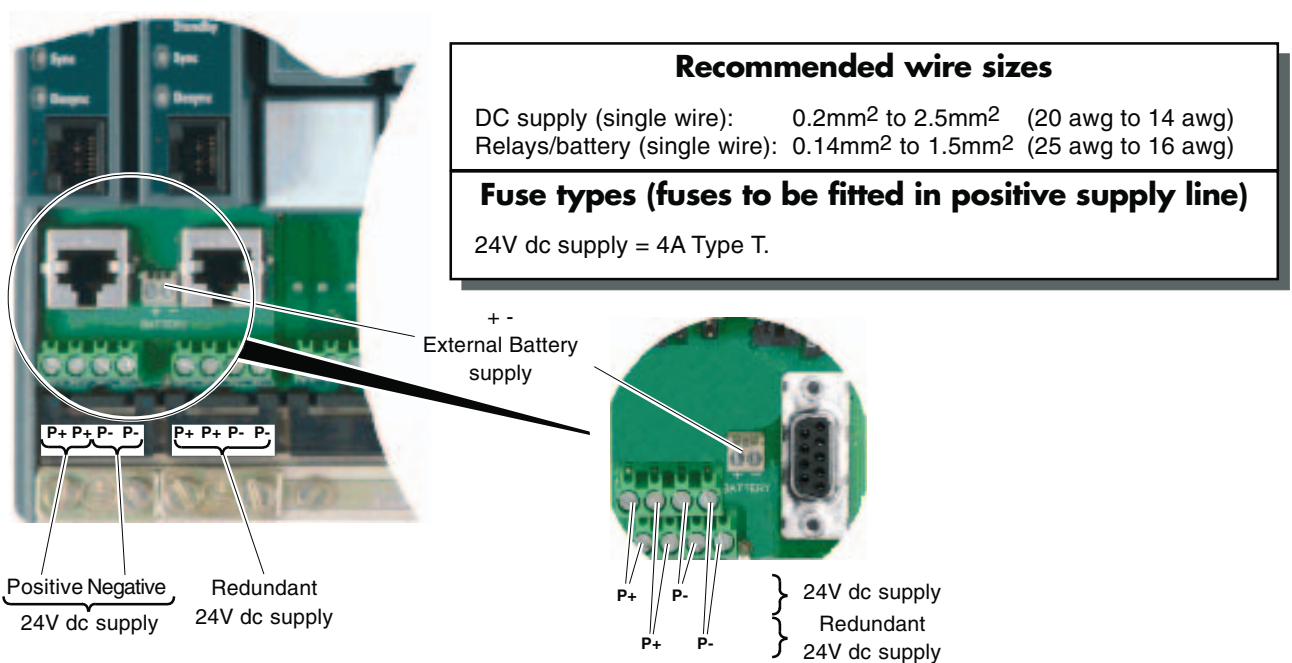

Figure 2.5.3 DC and relay connection details

2.5.4 Safety Earth

As shown in Figure 2.3.1a, an M4 earth stud connection is provided on the Base Unit. This stud should be bonded to a good local earth using multistrand tri-rated 1.5mm² (21A) green/yellow earth cable, with ring terminals for security.



2.5.5 Watchdog Relay

A Watchdog Relay is associated with each T2550R Module. The common and normally open terminals of each relay must be wired correctly, see figure 2.5.4b and figure 2.5.4c.

Note This is not supported in the Simplex Unit.

The contact ratings (resistive loads) for the relays are 30V ac/60V dc at 0.5A.

The operation of Watchdog Relay is under hardware control, making a number of health checks, before operating the relay. If during operation one of the health check fails, the Watchdog Relay goes into its alarm (power-off) state, see User Interface section.

The Watchdog Relay can be wired in series or in parallel. When in parallel, both T2550R modules have to fail, before the alarm becomes valid. When in series, the alarm becomes valid if either module fails. Figure 2.5.4b shows the relays wired in series to a 24V dc 'healthy' lamp. Figure 2.5.4c shows a parallel configuration, using an auxiliary relay to display both healthy and warning states.

Note The common and normally open contacts are open-circuit during power-off, and remain so for some seconds at power-up, until hardware control has become established. After that, the contacts are short-circuit when the relay coil is energised, and open-circuit when the coil is not energised.

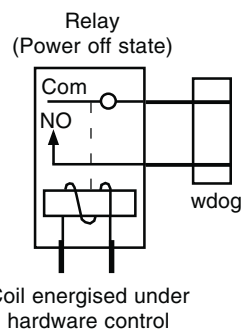

Figure 2.5.4a Relay Wiring

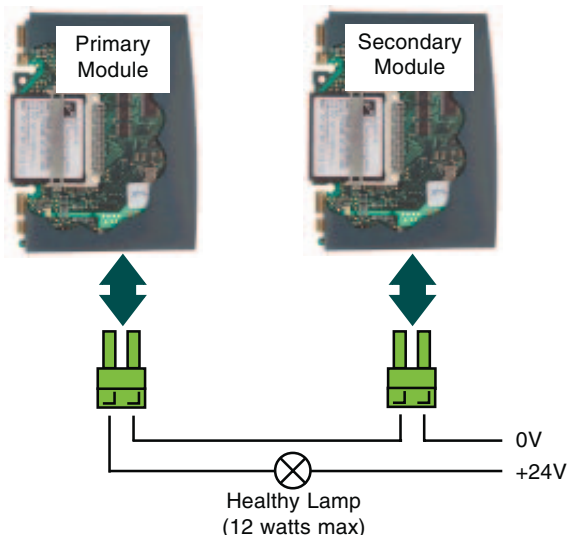

Figure 2.5.4b Watchdog Relay - Series Wiring

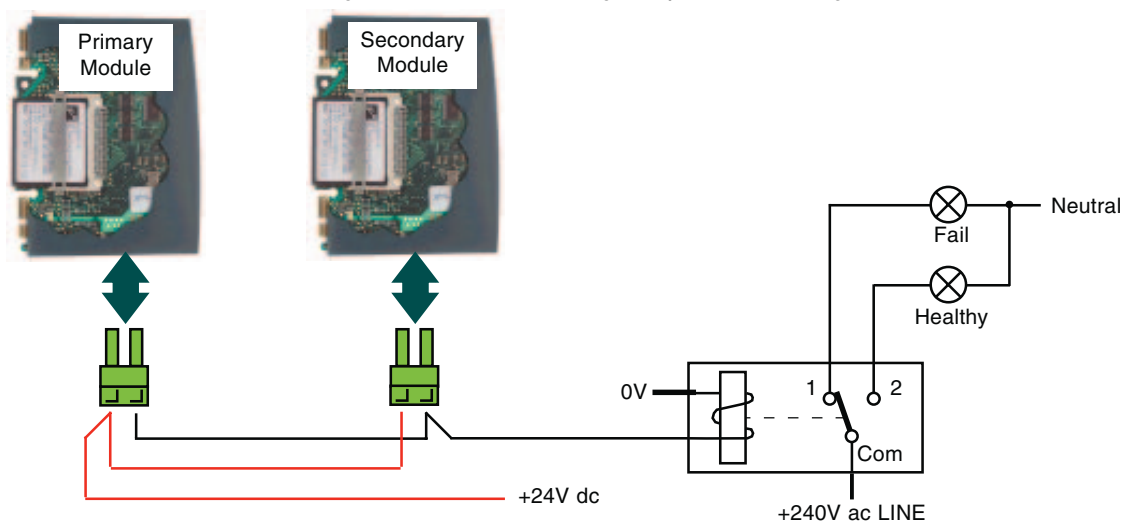

Figure 2.5.4c Watchdog Relay - Parallel Wiring

2.6 MODBUS COMMUNICATIONS

As Modbus is not the main method of communication, the instrument requires specific configuration in order to communicate with other devices using the Modbus network, see *Communications Manual* (Part no. HA028014).

A Modbus network requires the selected Base Unit to be configured as either Modbus Master or Modbus Slave. If configured as a Modbus Slave, it will appear at a configured slave address, i.e. fields of function blocks in the Tactician LIN Database are available as registers in the Modbus address map, for read and write by a Modbus Master device. If configured as a Modbus Master, it will collect data from Modbus Slave devices into fields of Tactician function blocks.

Modbus data is configured using the 'Modbus Tools', see *Modbus Tools Help* (Part no. HA028988).

Note If communicating with a T820 via Modbus network, the Instrument Options, COM port Protocol field MUST be set to Panel820.

2.7 PROFIBUS COMMUNICATIONS

As Profibus is not the main method of communication, the instrument requires specific configuration in order to communicate with other devices using the Profibus network, see *Configuration*.

Note If communicating via a Profibus network, specific Modbus registers must be configured using the 'Modbus Tools', see *Configuration*.

Intentionally left blank

CHAPTER 3 USER INTERFACE

This chapter presents standard and Profibus IOC Module User Interface information and explains the front panel LEDs and switches.

The main topics covered are as follows:

- Introduction (section 3.1)
- Status LEDs and Switches (section 3.2)
- Changeover And Communications LEDs, and Switches (section 3.3)

3.1 INTRODUCTION

This chapter describes the functions of the instrument’s LEDs, switches and network ports.

As shown in Figure 3.1, the items are arranged in groups on the instrument’s front panel, and each group is described in turn below. Table 3.1 is a concise list of the LEDs and their functions.

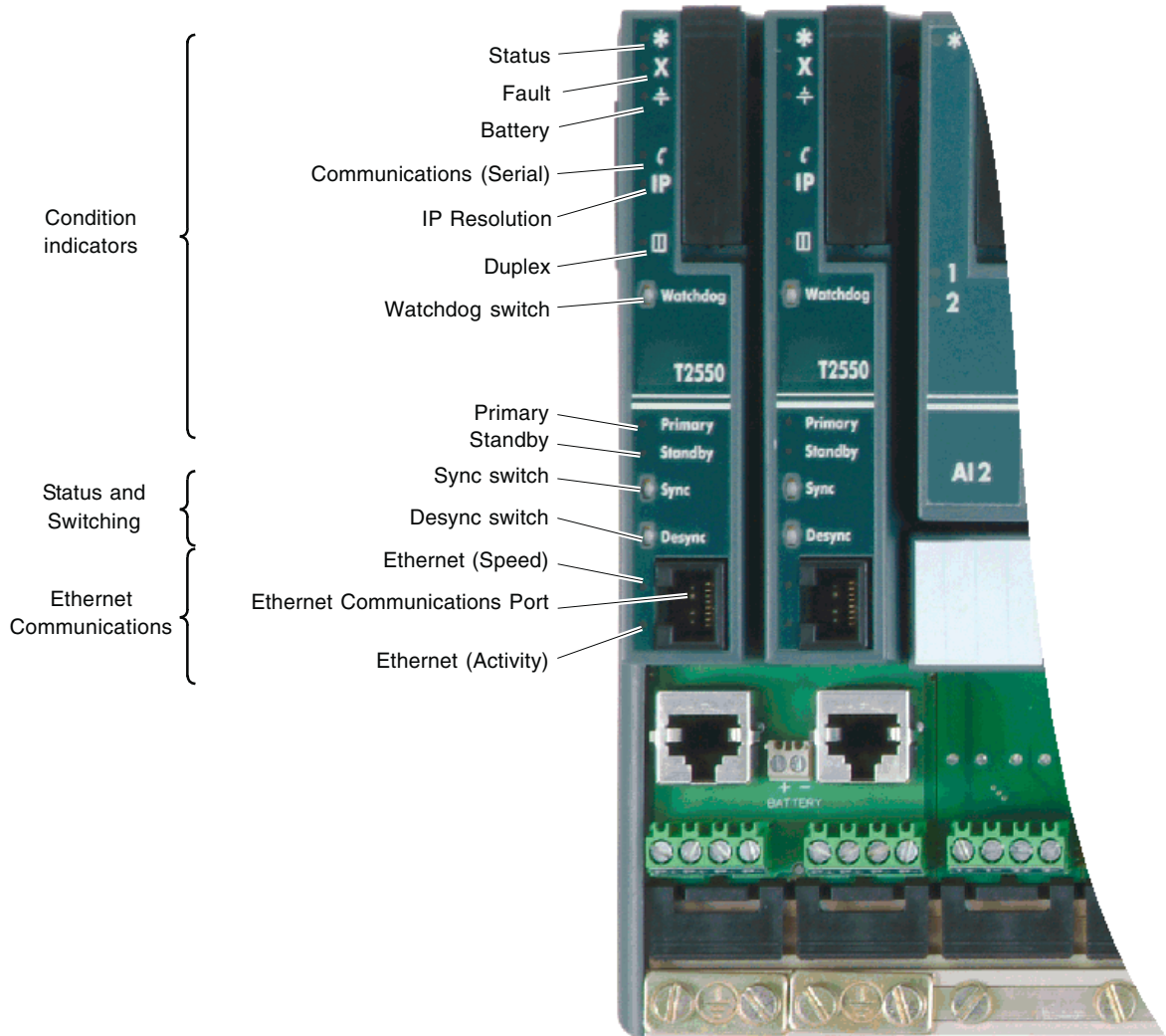

Note The Simplex Unit does not support the external power supply, but does support battery backup via an internal battery mounted on the Simplex Terminal Unit.

Figure 3.1 Front panel layout (Redundant Configuration)

3.1 INTRODUCTION (Cont.)

LED	Colour	Function
Status	Green	Main Power input valid
	Off	Main Power input failed
Fault	Red	Module missing/faulty, incorrect type/base, any H/W fault, Watchdog Failure if ALL other LED's are extinguished, including Status LED
	Flashing	Database file unsaved, missing, or faulty. A '*.dbf' and corresponding '*.run' file do not exist on the T2550
	Off	No H/W faults detected
Battery	Green	Battery OK
	Flashing	Battery failed or not fitted
	Off	Battery deliberately not fitted
Communications	Yellow	T2550R module transmitting field communications
	Off	T2550R module not transmitting field communications
IP Resolution	Yellow	IP address resolved successfully
	Flashing	IP address being resolved or the cable is broken/disconnected
	Off	IP address cannot be resolved or DHCP failure
Duplex	Green	Primary and Secondary T2550R modules are coupled
	Flashing	Primary and Secondary T2550R modules are decoupled
	Off	Not operating in Redundant mode
Primary	Green	This is the Primary T2550R module and a running strategy
	Flashing	The Primary T2550R module is loading a strategy or idle
	Off	Not Primary T2550R module
Standby	Yellow	This is the Secondary T2550R module and is synchronised
	Flashing	The T2550R modules are synchronising
	Off	Not the active Secondary T2550R module
Ethernet (Speed)	Green	100 MB Ethernet (speed) configuration
	Off	10 MB Ethernet (speed) configuration
Ethernet (Activity)	Yellow	Connected to live Ethernet network
	Sporadic Flashing	Ethernet network traffic detected
	Off	Ethernet connection invalid
<i>Notes</i>		
<i>1 All LED's flash at a rate of 600ms ON, 600ms OFF.</i>		
<i>2 If ALL LED's are extinguished, excluding the Fault LED, the instrument has Watchdogged. If the Options Switch SW2:S1 is set OFF, press the Watchdog switch to reset the instrument. This has no effect when a T2550R is not in a watchdog condition.</i>		

Table 3.1 LED functions

3.2 STATUS LEDS AND SWITCHES

This group of six LEDs, located at the top of the front panel, shows the overall status of the IOC Module.

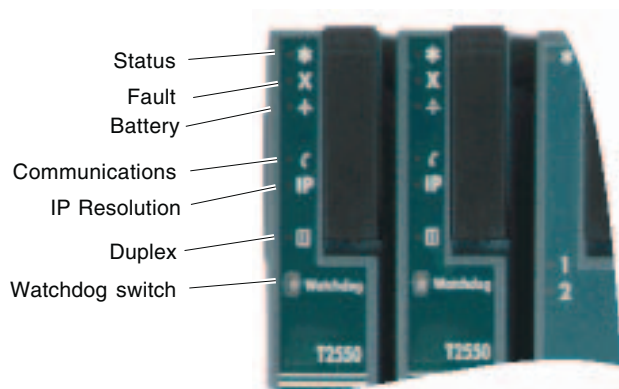

Figure 3.2 Status LEDs

3.2.1 ★ (Status) LED

This LED is illuminated green continuously if this IOC Module hardware is good and operating correctly.

The LED is off, if the IOC Module or the 24V power has failed.

3.2.2 X (Fault) LED

This LED is illuminated red continuously if any hardware fault exists with the IOC Module. It will also illuminate if any I/O module is faulty.

The LED will flash on (600ms) and off (600ms) if the database file is unsaved, missing or faulty. A '*.dbf' and the corresponding '*.run' file must exist on the T2550. This condition (flashing 'Fault' LED) is overridden by the existence of an I/O fault (steady 'Fault' LED).

The LED is off, if the IOC Module is operating correctly, after the database is

- saved, via the `Options.SaveDbf` field in the header block

Note This is used to save the LIN Database whilst running.

- stopped and saved via the appropriate menu command in the Terminal Configurator
- stopped and another is loaded from those present on the filing system

3.2.3 ⎓ (Battery) LED

This maintains a (72 hours minimum) backup of the data in the SRAM and Real-Time Clock (RTC). Once the start-up sequence is complete, this LED illuminates continuously green if the battery is healthy.

3.2.4 Ⓒ (Communications) LED

This LED indicates the status of the field communications systems associated with this instrument. This LED is illuminated yellow if field communications are being transmitted.

The LED is off, if this the IOC Module is not transmitting field communications.

3.2.5 IP (IP Resolution) LED

This LED is illuminated yellow continuously if this IOC Module successfully establishes an IP address.

The LED will flash on (600ms) and off (600ms) whilst an IP address is being resolved or if the cable is broken or disconnected.

The LED is off, if this IOC Module IP address cannot be resolved or a DHCP failure is detected.

3.2.6 Duplex LED (Redundant systems only)

This LED is illuminated green, if the Primary and Secondary T2550R modules are coupled, and successful data transfers are taking place between the two T2550R module.

This LED flashes on (600ms) and off (600ms) if the Primary and Secondary T2550R modules have failed or are decoupled.

The LED is off if the system is not running in redundant mode, either the the IOC Module is running without a second the IOC Module or is configured by the LIN Address Switch (SW1:S1, Off) for Simplex operation.

3.2.7 Watchdog Switch

Operation of the 'Watchdog' switch on a T2550 IOC Module that is in a Watchdog failure condition causes it to reset and attempt to re-boot if the Option switch (SW2:S1) is set OFF. If the Option switch (SW2:S1) is set ON, the T2550 IOC Module will automatically attempt to restart and any LED indication will be displayed momentarily.

Operation of this switch has no effect if the T2550R module has NOT watchdogged.

Note. A watchdogged CPU is indicated by the loss of all LEDs, excluding the 'Fault' LED.

3.3 CHANGEOVER AND COMMUNICATIONS LEDS, AND SWITCHES

The 'Sync' and 'Desync' switches are set behind the panel, and should be operated, when necessary, by a blunt, plastic tool such as the recessed end of a trim-pot adjuster.

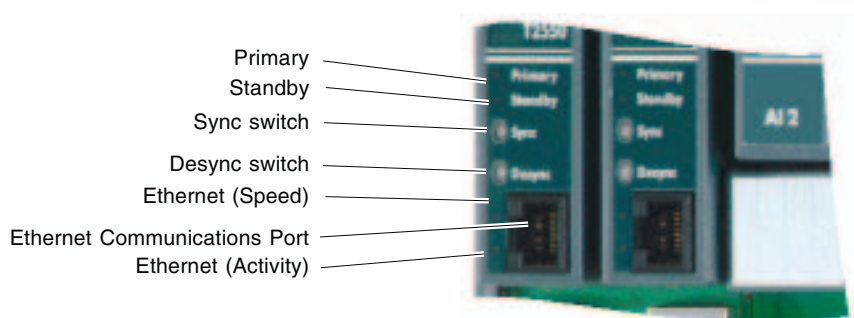

Figure 3.3 Changeover LEDs and switches

This group of components is located in the lower half of the instrument front panel, and is used to monitor and control the redundant / non-redundant mode selection. The group consists of four LEDs, 'Primary' and 'Standby', 'Ethernet (Speed)' and 'Ethernet (Activity)', and two switches 'Sync' and 'Desync'. The [Module Synchronisation section](#), below, gives a brief description of synchronisation.

3.3.1 Primary LED

This LED is illuminated green continuously if this IOC Module is currently the primary module and running a strategy. During start up and also while idle, this LED flashes on (600ms) and off (600ms), until a database has been loaded and is running successfully.

The LED is off, if this IOC Module is not the primary.

3.3.2 Standby LED

This LED is illuminated yellow continuously if this IOC Module is currently the secondary module of a synchronised redundant system, and is thus able to changeover to the primary if required.

If this T2550 is the secondary, the LED will flash whilst the T2550R Modules are synchronising.

The LED is off, if this IOC Module is not the active secondary.

3.3.3 Sync switch

If the Primary and Secondary T2550R modules are unsynchronised, operation of the Primary T2550R modules 'Sync' switch starts synchronising the T2550R modules.

If the Primary and Secondary T2550R modules are synchronised, operation of the Primary T2550R modules 'Sync' switch has no effect.

If the Primary and Secondary T2550R modules are unsynchronised, operation of the Secondary T2550R modules 'Sync' switch has no affect.

If the Primary and Secondary T2550R modules are synchronised, operation of the Secondary T2550R modules 'Sync' switch causes Primary/Secondary T2550R module changeover.

3.3.3 Sync switch (Cont.)

MODULE SYNCHRONISATION

Applicable only to redundant systems, synchronisation means the bulk transfer of all relevant data from that T2550R module which is designated the primary to that which is designated the secondary, followed by continuous maintenance of this copied data. This allows the primary and secondary T2550R modules to changeover should the primary module fail.

This synchronisation process takes place automatically, if both T2550R modules are powered-up together, and have previously been run as a redundant synchronous pair. Should either of the above conditions not be met, then, at power-up the primary and secondary T2550R modules adopt unsynchronised states. In such a case, the secondary module cannot changeover to the primary in the event of failure.

To synchronise the T2550R modules, the primary T2550R modules 'Sync' switch must be operated.

Once synchronisation has been achieved, the T2550R modules are said to be in primary synchronised state and secondary synchronised state. The secondary is now able to changeover to the primary if required.

TIME TO SYNCHRONISE

The time taken to complete the synchronisation process varies according to the complexity of the control strategy and on how heavily the Flash file system is used. Typically, the 'Load and Run' part of the procedure takes a number of seconds, however if the primary and secondary file systems are identical, synchronisation is almost instantaneous. During this period, the primary runs the control process as normal.

Note The redundant instruments may desynchronise or the secondary T2550R module may fail to load a Sequential Function Chart (SFC) if loading and unloading Sequences is not kept to a minimum during the synchronising process.

3.3.4 Desync switch

Operation of the primary T2550R modules 'Desync' switch causes synchronised T2550R modules to desynchronise, while the Primary T2550R module remains in control.

Operation of the secondary T2550R modules 'Desync' switch for longer than 3 seconds causes the secondary T2550R module to shutdown. When successfully shutdown, indicated when all LEDs are extinguished, the T2550R can be safely removed from the Terminal Unit.

3.3.5 Ethernet (Speed) LED

This LED is illuminated green continuously if this IOC Module is currently operating on a 100 MB Ethernet network.

The LED is off, if operating on a 10 MB Ethernet network.

3.3.6 Ethernet (Activity) LED

This LED is illuminated yellow continuously if this IOC Module is currently connected to hub, switch or other device connected with cross-over cable.

If general Ethernet communications traffic is detected, the LED will flash irregularly as traffic is received.

The LED is off, if no valid Ethernet connection is detected.

3.3.7 Ethernet Communications Port

This RJ45 communications port establishes communications for either 10 MB or 100 MB Ethernet network.

CHAPTER 4 START-UP

This chapter describes the start-up sequence for the T2550 IOC Modules. Topics covered include the differences between redundant and non-redundant systems and start-mode (hot/cold etc.).

The main topics covered are as follows:

- Redundancy Modes ([section 4.1](#))
- Start-Up Modes ([section 4.2](#))
- Starting A Single (Simplex) T2550S module ([section 4.3](#))
- Starting A Pair Of (Duplex) T2550R modules ([section 4.4](#))

Note The Profibus communications supports Cold Start only.

4.1 REDUNDANCY MODES

Redundant (Duplex) mode is where two T2550R modules (Primary and Secondary) are fitted and required to act in such a way that one can take over from the other in case of failure. In such a case, one T2550R module (normally the left-hand one) is called the ‘primary’ and the other the ‘secondary’. The secondary continuously tracks the primary so that it can take over with minimum disturbance to the controlled system. It also monitors communications to other nodes and the I/O modules.

Non-redundant (Simplex) mode is where there is only one T2550S module.

Note A second T2550S module is not supported in Simplex mode.

Redundant/Non-redundant mode is selected using the LIN Address Setting switch (SW1:S1) on the Duplex Terminal Unit, as shown in the *Terminal Unit Switches* section.

4.2 START-UP MODES

The required start-up mode is selected using the ‘Options’ switch (SW2), see *Terminal Unit Switches* section. This allows ‘Hot’, ‘Hot/Cold’, or ‘Cold’ to be selected. (Each start mode has a two switch configuration) [Figure 4.2.1a](#), below, shows a simplified flow diagram for the different modes.

Note The combination of SW2:S2 and SW2:S3 switches on the Duplex Terminal Unit and SW1:S9 and SW1:S10 on the Simplex Terminal Unit, also allows the automatic generation of a basic strategy, that will require further configuration.

4.2.1 Hot start (LIN Terminal Unit Only)

Hot start means that the T2550 instrument restarts from where it stopped running. A suitable time period (Cold Start Time) is configured in the ‘Header’ block of the control database, and if this period is exceeded after the database stops running, then a hot start is not permissible. The Cold Start Time for any process can be defined as: A pre-set duration, following power off or power failure (database stopped), after which a *Hot Start* is not possible, and a *Cold Start* must be initiated instead.

A brownout time can be set in the ‘Header’ block, and if power to the T2550 instrument is lost for this duration or longer, the brownout alarm will be set (also in the ‘Header’ block). This brownout time can be defined as a signal that a power variation or partial power failure longer than the defined Brown out Time has occurred. Any power variation or partial power failure shorter than the defined Brown out Time will continue without indication.

For this instrument, if the Hot start fails (because the database is corrupted or because the Cold Start Time has been exceeded) the database will be cleared and the instrument will enter an ‘Idle’ state and remain there until physically restarted, see [Hot/Cold start](#).

4.2.2 Cold start

Cold start means that the instrument re-starts with the previous database loaded, but with all parameters and values set to starting values appropriate to the process (that is, re-initialised). If the cold start fails the database will be cleared and the instrument enters an 'Idle' state and remains there until physically restarted.

COLD START PARAMETER FILE

In the event of a cold start, the instrument searches for a file with the same name as the .dbf file just loaded, but with the extension .CPF. If such a file is found it is executed. The .CPF file, created using any text editor, consists of Structured Text (ST) style assignment statements (one complete statement per line of text) that

- allocate the current cold start parameter values to database block fields
- define the Reset Data Set

Note A .CPF file is a parameter overlay file storing values that are initialised when a Cold Start is requested. LINTools allows interrogation of this file to determine the Cold Start parameters.

Fields that are normally 'read only' can be written to from the .CPF file by adding the '>' character to the beginning of the assignment statement. A .CPF file can also include ST comment lines, e.g. (* Comment *). The instrument header block includes a 'CPF alarm' to indicate if any problems were encountered whilst executing the .CPF file.

Sample .CPF file:

```
(* Production plant Cold Start Initialisation --- .CPF file *)
(* Ensure no automatic control until started *)
PIC-023.Mode := "Manual";
XCV-124.Mode := "Manual";

(* Ensure vent valves open *)
XCV-124.Demand := "False"; (* Open *)
XCV-123.Demand := "False"; (* Open *)

(* Reset profile to default *)
Profile.A0 := 23.4; (* Start temp Deg C *)
Profile.A1 := 34.5; (* First target temp Deg C *)
Profile.A2 := 2.0; (* Ramp rate Deg C / min *)

(* Initialise totalisation block*)
>COUNT-01.NTotal := 10;
>COUNT-01.NTotFrac := 0.5;
```

Reset Data Set

The Reset Data Set is a list of defined parameters that remain unaltered in the .dbf file when a runtime save is performed using the **Options.SaveDBF** in the header block. The Reset Data Set supports a maximum 2560 parameters. However, 3 parameters are reserved for Date, Time and Checksum, that are used to validate the data. The mode (MODE), local setpoint (SL) and output (OP) parameters from each Control block in the database are allocated by default, but additional parameters can also be added to the .cpf file. Any parameter in the Reset Data Set can be omitted by preceding the parameter with -, negative symbol.

Note To save a fixed value, e.g. a setpoint, enter the parameter in the .cpf file, e.g. TIC0101.SL := 64;. To save values from recently changed parameters, omit the parameter from the Reset Data Set using the -, negative symbol, e.g. -TIC0101.SL := 64;, and perform a runtime save from the header block, **Options.SaveDBF**.

The Reset Data Set for the LOOP_PID block uses extra parameters due to the more complex nature of the block. The Reset Data Set of the LOOP_PID block is *AutoMan*, *SP1*, *SP2*, *AltSPEn*, *ManOP* and *ReStrtOP*.

Note *ReStrtOP* is a hidden non-volatile parameter from which the volatile output parameters are derived on power up. It is normally set to 0 (zero) is generally saved to the .dbf file as 0 (zero).

4.2 START-UP MODES (Cont.)

4.2.3 Hot/cold start

This setting causes the instrument to attempt a hot start. If the hot start fails, however, instead of going straight into idle state as with 'hot start', the instrument attempts to carry out a cold start. If the cold start fails the database will be cleared and the T2550 IOC Modules enter an 'Idle' state and remain there until physically restarted.

4.2.4 Start-up routine

The following flowchart graphically describes the start-up routine.

Note The Profibus communications supports Cold Start only.

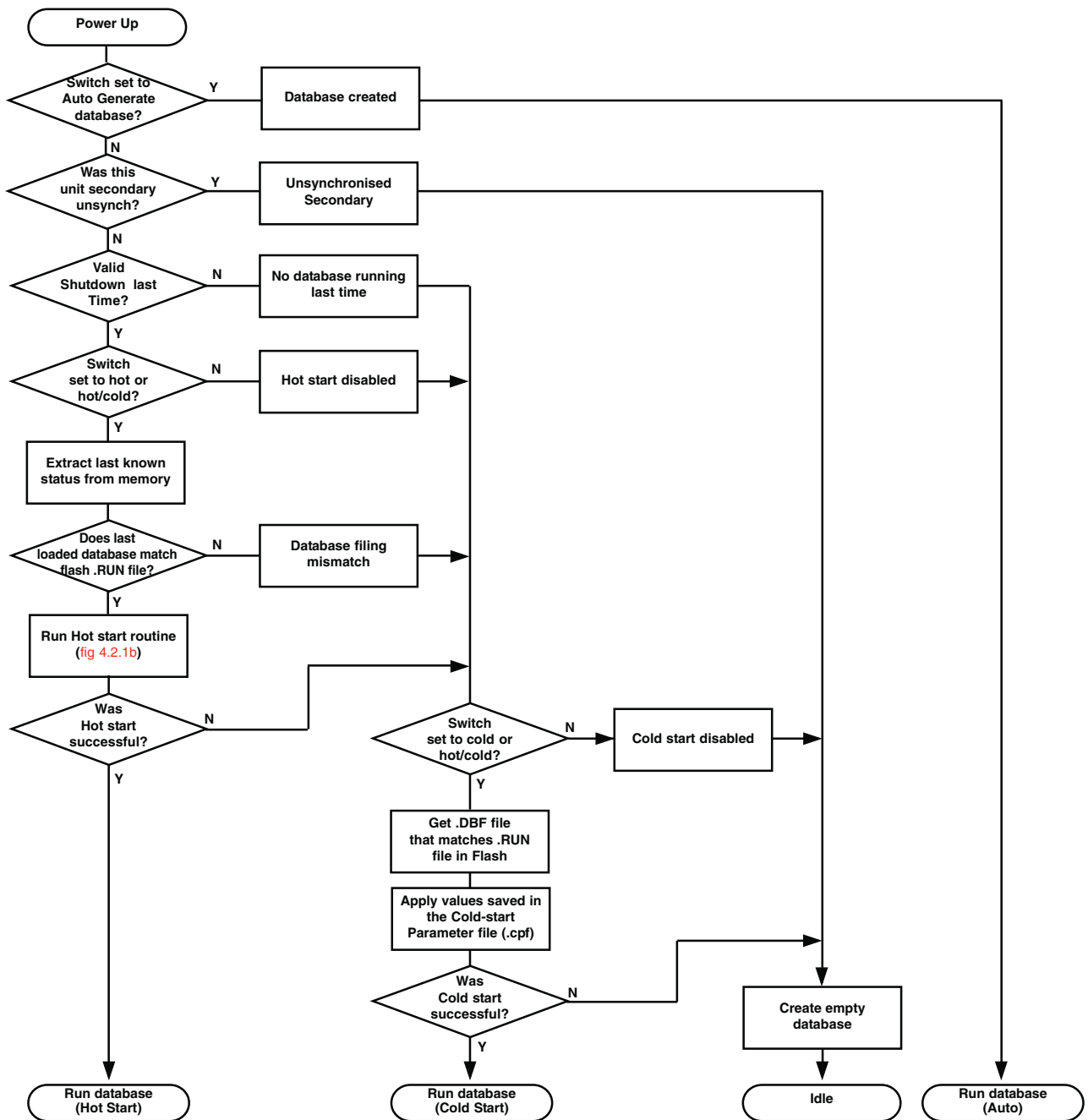

Figure 4.2.1a Simplified start-up flow diagram

4.2 START-UP MODES (Cont.)

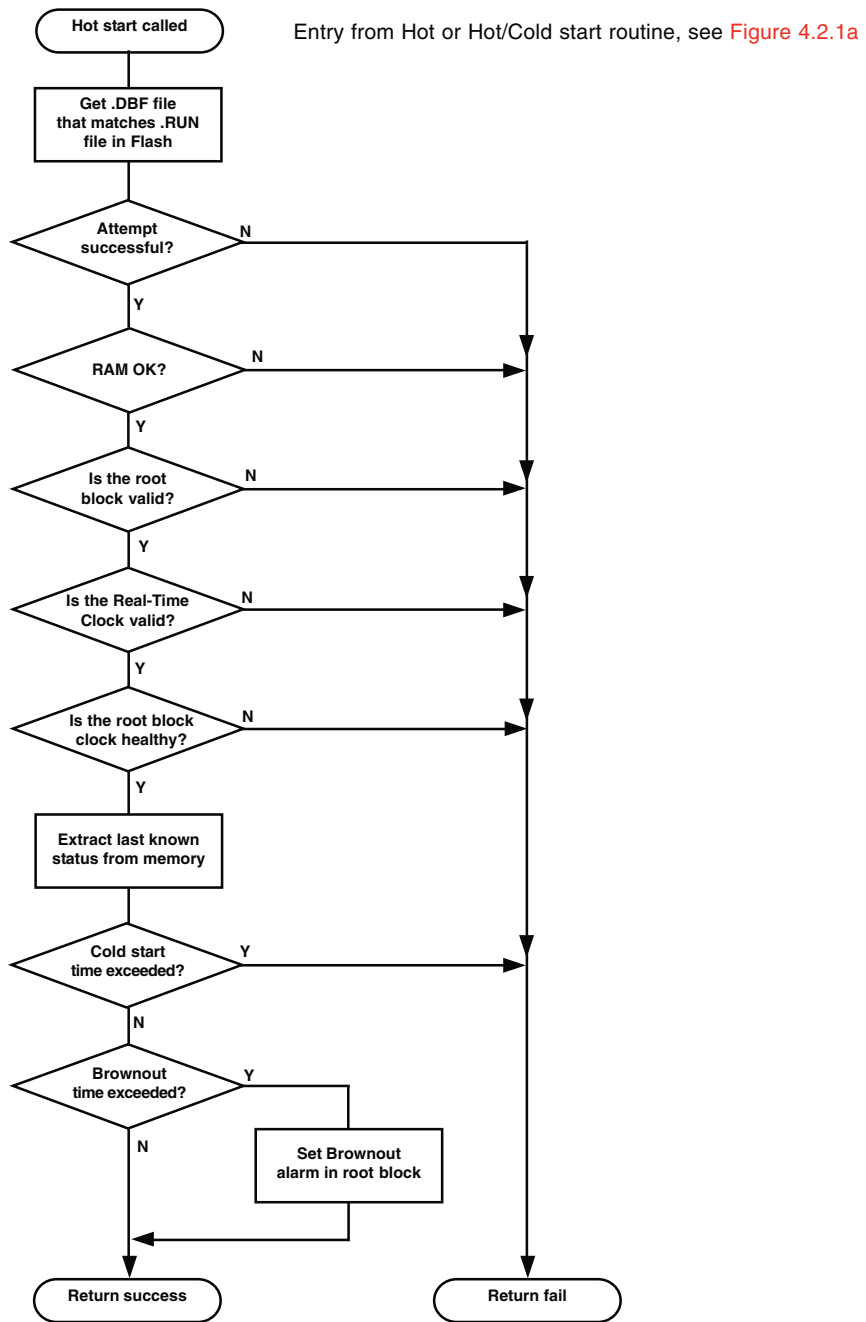

Figure 4.2.1b Hot or Hot/Cold start flowchart

4.3 STARTING A SINGLE (SIMPLEX) T2550S MODULE

4.3.1 Start-up routine

The Start-up routine is subject to the successful completion of the Power On Self Tests (POSTs). For further information concerning the Power On Self Tests (POSTs), see *Power On Self Tests (POSTs)* and *POSTs and Error Number* sections.

OFF STATE

In the Off state, all LEDs are extinguished.

STARTING STATE

When power is applied, the relevant 'Status' LED illuminates green immediately.

The 'Primary' and 'Standby' LEDs flash intermittently until the T2550S Module is initialised, at which point the 'Primary' LED illuminates, see *Error Conditions and Diagnostics* section.

The start-up procedure concludes with the T2550S Module attempting to establish Ethernet (ELIN) communications. During this period, the 'Primary' LED flashes on (600ms) and off (600ms).

OPERATING STATE

When the start-up sequence is complete, then as a minimum, the 'Status' LED is illuminated continuously green.

The 'Primary' LED will be illuminated green continuously if a database is running, or it will flash if a database is loading or the T2550S Module is idle.

The 'Communications' LED will also be illuminated yellow if the associated communications links are operating correctly. It will flash intermittently when receiving valid messages.

In addition, if any other communications are in progress, the appropriate Ethernet LEDs will be illuminated, either continuously or intermittently, see *User Interface* section for more details of the 'Communications' LEDs.

If the Simplex T2550S module is installed and back-up batteries are fitted, the 'Battery' LED is illuminated green as appropriate.

WATCHDOG RELAY

The Watchdog Relay is in its alarm state until the software has initialised correctly.

4.4 STARTING A PAIR OF (DUPLEX) T2550R MODULES

4.4.1 Start-up routine

This start-up routine is similar to that described for a single T2550R module, see [Starting a Single \(Simplex\) T2550S Module section](#), except in the control and action of the ‘Standby’ and ‘Duplex’ LEDs. This is due to the modules assessing the Primary/Secondary criteria.

POWERING UP DECISIONS

Figure 4.4.1 shows the states possible with a pair of T2550R modules in Redundant mode.

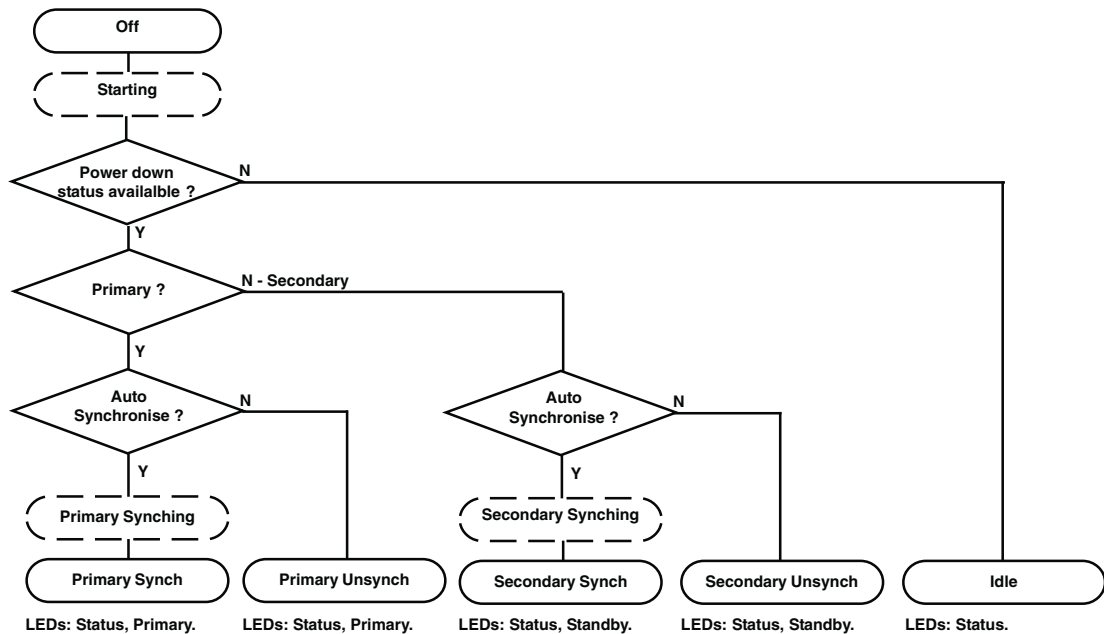

Figure 4.4.1 Power-up redundancy states for a pair of T2550R modules in Redundant mode

PRIMARY/SECONDARY CRITERIA

With T2550R modules in Redundant mode, it is necessary that one be defined as the primary; the other as the secondary. As described in the [Redundancy Modes section](#), the primary initially assumes control and the secondary tracks the primary such that it can assume control should the primary T2550R module fail. Which T2550R module powers-up as the primary is determined as follows:

- Decisions are made on the basis of information held in battery-backed memory. This information contains data relating to whether this T2550R module was primary or secondary prior to the last power off. If both T2550R modules power-up as they last powered down, then the T2550R modules will attempt to power up with the same primary and secondary assignments. If the power down information in the two modules is conflicting, or not available, because the battery is not connected, both processor modules will enter an idle state (decoupled), and will not load or run a LIN Database. The power down state is initialised so that the modules will start with default primary and secondary assignment at the next power cycle.

4.4.1 Redundant mode (Cont.)

REDUNDANCY DECISIONS

Normal Duplex (redundant) operation will take place only if the primary T2550R module believes that itself and the secondary T2550R module have an equal view of the ELIN network, while accessing the health of the I/O.

When acting as a redundant pair, the primary and secondary T2550R modules independently derive a communications status, indicated by the 'IP Resolution' LED. If the LED is steady, the IP address is healthy. Should this LED flash, an IP address fault has been detected, and, if the LED is extinguished, the IP address cannot be resolved or DHCP failure has occurred.

The decision to remain synchronised, desynchronise or changeover, is always made by the current primary T2550R module, and then only whilst the two units are synchronised, i.e. an attempt to synchronise will be allowed to complete, and only after completion will the decision be made. It is dependant on which T2550R module has the best view of the network. For example, if it is regarded by the primary T2550R module that;

- both modules hold the same outlook of the network, the primary and secondary modules remain synchronised.
- the primary T2550R module holds a better outlook of the network, the primary and secondary modules desynchronise and a changeover will NOT occur.
- the secondary T2550R module holds a better outlook of the network, the primary and secondary modules desynchronise and a changeover occurs.

However, if the communications status is unstable, the decision is deferred. This prevents spurious desynchronise or changeover decisions being made as faults are introduced to or removed from the network.

AUTOSYNCHRONISATION

Once the primary/secondary status of the T2550R module's has been determined, the system must decide whether synchronisation of the primary and secondary should be automatic or whether it should proceed only after a request from the operator ('Sync' switch). This decision is made as follows:

If the T2550R module's are powered-up within a short time of each other, AND they were running as a synchronised pair prior to power-down (data held in memory), then synchronisation will take place without operator intervention.

If either of the above conditions is not met (or if the data held in memory is not available) then both units will enter unsynchronised states in which case the secondary cannot take over from the primary. This state will continue until the 'Sync' switch on the primary T2550R module is operated.

SYNCHRONISATION

During synchronisation (automatic or manual), the primary T2550R module carries out the following:

- It duplicates all primary T2550R modules strategy files on to the secondary T2550R module.
- It instructs the secondary T2550R module to load the relevant database.
- It transfers current block data to the secondary T2550R module.

During the synchronisation process, the 'Standby' LED on the secondary T2550R module flashes (600ms ON, 600ms OFF). Once synchronisation is complete, it is continuously illuminated yellow, the 'Duplex' LED on the primary T2550R module is illuminated green and redundant operation starts, with the T2550 IOC Modules in their synchronised states. In these states, the T2550 IOC Modules will remain synchronised.

Note In redundant operating mode, the secondary T2550R module will not permit any LIN database messages or writing to its filing system. However it will respond to all other messages.

4.4.1 Redundant mode (Cont.)

TIME TO SYNCHRONISE

The time taken to complete the synchronisation process varies according to the complexity of the control strategy and on how heavily the Compact Flash filesystem is used. Typically, the 'Load and Run' part of the procedure takes a number of seconds, however if the primary and secondary file systems are identical, synchronisation is almost instantaneous. During this period, the primary runs the control process as normal.

Where primary and secondary filing systems have substantial differences (e.g. when attempting synchronisation for the first time), multiple synchronisations may be required to copy all the files to the secondary T2550R module. When such is the case, it can be detected from the 'Red_Ctrl' block 'sync' fields.

4.4.2 Two Processor Non-redundant (Simplex) mode

A two T2550S module non-redundant system is not supported, see [Starting a Single \(Simplex\) T2550S Module section](#).

CHAPTER 5 CONFIGURATION

This chapter presents and describes the recommended Configuration Tools and Configuration issues concerning the T2550 instrument.

The main topics of this chapter are:

- Tools: The Automatic I/O Build and Configuration Tools ([section 5.1](#))
- Automatic I/O Build ([section 5.2](#))
- LINtools ([section 5.3](#))
- Terminal Configurator ([section 5.4](#))
- Modbus Tools ([section 5.5](#))

Note *Modbus Tools is also used to configure T2550 Profibus Slave parameters.*

5.1 TOOLS: THE AUTOMATIC I/O BUILD AND CONFIGURATION TOOLS

Most configuration will be done before despatch, using the LINtools configuration tool. However, at start-up a basic LIN Database and the communications parameters can be automatically configured for the T2550 instrument using the Automatic I/O Build switch configuration on the Terminal Unit. There is also a basic Terminal Configurator resident within the instrument. (In redundant mode the program is resident only on the Primary T2550R module). It employs the standard LIN block structured approach. The *LIN Blocks Reference Manual* (Part no. HA 082 375 U003) gives full details of the software function blocks available for control strategies, and how to configure their parameters.

Using the recommended LINtools program also allows the creation of new LIN Databases, and the editing of existing configurations on-site and on-line, usually to accompany modifications to the processing plant. The *LINtools Help* (Part no. RM 263 001 U055) should be referred to for details of the reconfiguration procedures using the LINtools program. It employs the standard LIN block-structured approach. The *LIN Blocks Reference Manual* (Part no. HA 082 375 U003) gives full details of the function blocks available for control strategies, and how to configure their parameters.

Note *A user is not permitted to perform On-line Reconfiguration if the T2550 IOC Modules are synchronised.*

All processed data collected in the LIN Database can also be transferred via Modbus communications protocol, see *Communications Manual* (Part no. HA 028 014) and configured using the Modbus Tools, *Modbus Tools Help* (Part no. HA 028 988).

Note *The Modbus Tools MUST also be used to configure specific Modbus address registers, as described in [Configuring Profibus Communications using Modbus Tools](#), allowing this instrument to operate as a Profibus Slave.*

5.2 AUTOMATIC I/O BUILD

The instrument is capable of detecting what I/O hardware is currently fitted. This information is then used to automatically create the appropriate I/O channel blocks in a LIN Database, and configure them to match the real hardware. This automatically generated LIN Database does not result in a complete, usable control strategy, as all of the I/O channel blocks (apart from the digital input function blocks) require further configuration, e.g. thermocouple type requires a millivolt range, but it does provide the user with sufficient information on what I/O is present, forming a good starting point for the user to begin building the strategy.

5.2.1 Preparing for the Automatic I/O Build

Before the Automatic I/O Build can be started, all power to the unit must be isolated, and the Terminal Unit Hot/Cold Start switches must be configured correctly, see *Terminal Unit Switches* section, and all required I/O modules must be fitted in the appropriate slots.

Note All existing '.run' files will be deleted when this operation is executed.*

Only then should power be applied to the instrument, initiating the automatic generation of a LIN Database, and a corresponding '_auto.run' file. The automatically generated LIN Database includes appropriate Header, Module, Calibration, I/O, and other Diagnostic function blocks, see *Diagnostic Block*.

Note Each automatically generated I/O channel block is automatically configured to match the real hardware and assigned a unique meaningful 8-character name, see Table 5.2.1. I/O channel blocks are assigned to the slowest I/O User Task, User Task 3.

The LIN Database will run automatically, it is unnamed (unsaved), and will remain so, unless

- automatically saved, if the Options.SaveDBF bit in the TACTICIAN header block is set
- the 'Save as' command at the instrument level of the 'manufacturers Network Explorer' is used
- the 'Save' command in the 'Terminal Configurator' is used
- the LIN Database is open in LINtools, then attached to the instrument via the 'Online Reconfiguration' command, see [Uploading Instrument Control Strategy](#). The 'Save' command can then be used to save the instrument LIN Database.

Note The 'FAULT' LED (red) will flash while an unsaved LIN Database or changes to a LIN Database exist in the instrument. The only constraints on the name of the LIN Database is that it must be a unique 8-character string, although it is recommended that the name is the Instrument Type and the LIN Address, i.e. T2550_of.

5.2.1 Preparing for the Automatic I/O Build (Cont.)

The channel indices are affected by the type of the channel, e.g. '03X11_1A' specifies the eleventh *digital input* channel on the third module, *not* the eleventh channel on the module. A mixed-type module with three analogue inputs and three digital inputs in the third slot on a rack at node address 01, results in I/O channel blocks named '03M01_01', '03M02_01', '03M03_01', '03X01_01', '03X02_01' and '03X03_01'.

Block Type	Naming Convention	Description
Header Block	T2550_xx	xx is the node address
Module Block	Modyy_xx	Mod is the Module type, yy is the SiteNo, and xx is the node address
Diagnostic Block	[block template name]_xx	block template name may be condensed, xx is the node address
Calibration Blocks	CALn_xx	n is the Task number, and xx is the node address
Analogue Input Channel Index	yyMzz_xx	yy is the SiteNo, zz is the channel, and xx is the node address
Analogue Output Channel Index	yyPzz_xx	yy is the SiteNo, zz is the channel, and xx is the node address
Digital Input Channel Index	yyXzz_xx	yy is the SiteNo, zz is the channel, and xx is the node address
Digital Output Channel Index	yyYzz_xx	yy is the SiteNo, zz is the channel, and xx is the node address

Note All indices (SiteNo and Channel) start at 1, not 0. LIN node addresses less than 10 do not contain a preceding 0.

Table 5.2.1 Naming Conventions of the automatically generated blocks

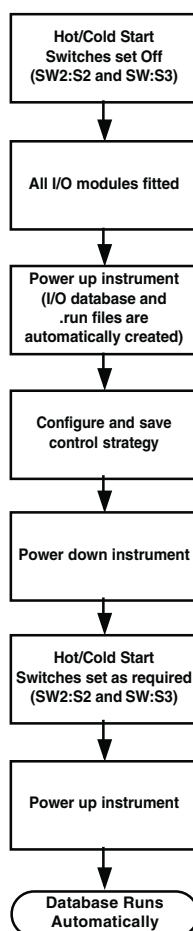

Figure 5.2.1 Automatic I/O generation routine

5.3 LINTOOLS

IMPORTANT *The recommended method of editing a LIN Database is via the LINTools software.*

The LINTools program provides the user with a view of the control strategy components that compose the configuration of a single device, and an easy way to manage those components. There may be more than one of each component, but not always all component types.

- I/O Modules Database (file extension .dbf)
- Databases (Function Block Diagram - FBD, file extension .dbf)
- Sequences (Sequential Function Chart - SFC, file extension .sdb)
- Action block methods (Structured Text - ST, and Ladder, file extension .stx and .sto)
- Data Recording (file extension .uxg)
- User Screen PageSets (file extension .uxp and .ofl)
- Setpoint Programs (file extension .uys)
- Modbus Gateway configurations (file extension .ujg and .gwf)

In summary, LINTools

- Provides a simplified view of the instrument configuration
- Provides Build and Download functions
- Assigns LIN names and node addresses to external databases

Note External databases (EDBs) are LN Databases running in other LIN instruments.

- Provides On-line Reconfiguration to a running LIN Database only

Note On-line Reconfiguration does not apply to other files, i.e. Modbus Gateway file (.gwf), Sequential Function Chart file (.sdb), or User Screen PageSets file (.ofl), etc..

5.3.1 On-line Reconfiguration

On-line Reconfiguration of an I/O system may involve adding and editing blocks and wires in a running strategy. Changes, such as adding new function blocks and wires are automatically made as 'Tentative'. However, when using on-line reconfiguration, LINTools will not permit changes to certain fields of I/O channel blocks unless specific criteria is met. To ensure that changes made to function block fields do not impact on the running strategy until the user decides, comes in the form of detaching the function block from the strategy.

On-line Reconfiguration allows the user to make 'Tentative' edits to a running control strategy before applying changes. During on-line reconfiguration, the user can edit a LIN Database loaded in LINTools, and 'Try' changes in the instrument to ensure the changes have the desired affect. The user can then either 'Apply' these changes, making them permanent in both LINTools and the instrument; 'Discard' the changes (restoring the last saved data); or 'Untry' the changes (removing the changes from the live instrument, but retaining them in the Computer, so that the changes can be altered in LINTools before again using the 'Try' command).

Caution

Any changes made directly to a running block cannot be 'Tried/Untried', but are applied immediately (e.g. changing the value of a function block's field).

In order to make 'Tentative' changes to a running function block, the user must choose to 'Unlink' that function block in LINTools, so any changes are not directly applied to the function block in a running control strategy. The user can then 'Try' the changes as normal. The instrument creates a new copy of the function block, with all of the changes, and runs it in place of the original. At this point the T2550 instrument will be running the altered LIN Database, however, the original function block is still present in the LIN Database, so can be restored if 'Untry' or 'Discard' is selected). The user can also 'Re-link' the function block, discarding all changes made to it, by selecting 'Undo Unlink' on the function block.

5.3.2 Preparing to run LINtools

Getting ready to run LINtools consists of two main topics:

- Connecting the instrument to a Computer.
- Creating a Project folder.

CONNECTING TO A COMPUTER

The instrument can be accessed over the Ethernet network via an Ethernet hub/switch connected to the 'Ethernet Communications port' on the primary T2550R module and to the Ethernet port on the Computer.

Note To configure a redundant mode instrument (two synchronised T2550R modules), the Computer must be linked to the primary T2550R module, not the secondary T2550R module.

CREATING A PROJECT FOLDER

The use of LINtools is restricted only by the requirement of a Project folder (or Project Database) containing appropriate Network and Instrument folders. A New Project folder is created via the **New Project wizard**, started from the **Start > Programs > ... > New Project** command. Thereafter use the context-sensitive menus to create the required Network and Instrument folders.

Note '...' indicates the file path of the installed software.

Each Network folder represents a network and type defined via the **New Network wizard** and contains all the Instruments within that network.

Each Instrument folder represents a type of instrument defined via the **New Instrument wizard** and contains all the files required for the successful operation of the control strategy by the instrument at the specified address.

Note Any automatically generated LIN Database can be saved to the correct Instrument folder using LINtools.

If using the manufacturers Project structure software, when all the Networks and Instruments have been created, use the **Build 'Project Name'** command to enter all the configured project information into the Project database.

Note The Build command can be used at any time, but Networks must be built before Instruments.

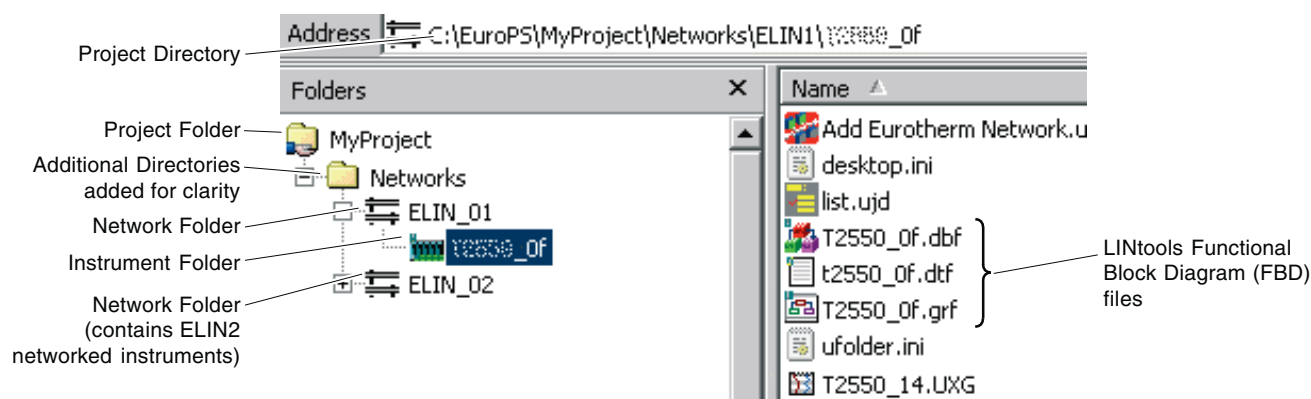

Figure 5.3.2 Project directory structure

5.3.3 Running LINtools

An empty LINtools instance can be started via the  Start > Programs > ... > LINtools Engineering Studio command.

Note '...' indicates the file path of the installed software.

Use the 'Open' command to locate an existing LIN Database on the Computer and then select the required file type and finally open, or simply double-click the LINtools Database file (.dbf), see *LINtools Help* (Part no. RM263001U003) for details of LIN Database configuration and Online Reconfiguration procedures using the LINtools program.

Note If the instrument is currently running an automatically created LIN Database (_auto.dbf) it can be copied to a Computer using the commands in the manufacturers Network Explorer, see *Uploading Instrument Control Strategy* section.

UPLOADING INSTRUMENT CONTROL STRATEGY

When a LIN Database has been automatically generated it only exists within the instrument. However, using the manufacturers Network Explorer running on a Computer allows the LIN Database to be stopped, and then saved, with an appropriate filename. Then using the copy to command, to copy this LIN Database to an instrument folder, so it can be edited using LINtools.

Once the automatically generated LIN Database has been copied and added to an instrument folder, it can be opened in LINtools. LINtools can only display a list of function blocks in order of creation. This function block list can then be converted in to a graphical representation to clearly show the wiring between each function block. The LIN Database file can now be edited, and when satisfied, saved and downloaded to the instrument, see *Downloading Instrument Control Strategy*. If the LIN Database was edited before it was downloaded, a dialog appears indicating that the LIN Databases are not the same. This must be confirmed before the download can start.

Note Once the copied LIN Database has been opened in LINtools, sufficient information is available to allow LINtools to perform On-line Reconfiguration of the instrument LIN Database.

IMPORTANT *On-line Reconfiguration changes may seriously effect the operation of your system.*

DOWNLOADING INSTRUMENT CONTROL STRATEGY

Any LIN Database currently running in an instrument can be edited using the On-line Reconfiguration, see *On-line Reconfiguration* section. However, the LIN Database file, .dbf, and any other files on the Computer included in the download list, can be downloaded at any time. Appropriate indication is displayed when the LIN Database on the Computer and the Instrument LIN Database do not correspond, allowing the user to decide whether to continue.

RECONFIGURING INSTRUMENT CONTROL STRATEGY

During On-line Reconfiguration, using the Apply command will save changes in the running LIN Database, but any other files, i.e. Modbus Gateway file (.gwf), Sequential Function Chart file (.sdb), or User Screen PageSets file (.ofl), etc., that have been edited using the relevant Tools, or are dependant on the LIN Database at load, MUST be downloaded. However, after files have been downloaded and the strategy is stable, either the application will have to be stopped and then loaded again, or the power to the instrument must be isolated and then re-applied.

IMPORTANT *On-line Reconfiguration only applies to LIN Database files, .dbf.*

5.4 TERMINAL CONFIGURATOR

IMPORTANT *This can be used to edit a LIN Database but is not recommended. The recommended method of editing a LIN Database is via the LINtools software.*

The Terminal Configurator provides the user with a basic program which can be used to configure and monitor a control strategy. It can

- Provide offline instrument configuration
- Provide Build and Download functions
- Assign LIN names and node addresses to external databases

Note External databases (EDBs) are LIN Databases running in other LIN instruments.

- Provide On-line Reconfiguration to a running LIN Database

5.4.1 On-line Reconfiguration

On-line Reconfiguration of the I/O system involves edits to running blocks (e.g. to add I/O modules or extra channels on the same I/O module), but changes are made as 'Tentative', i.e. capable of being Tried/Untried, since a change made to one I/O block can potentially affect many others. Changing channel type, for example, could cause a status error in all channel blocks assigned to it (i.e. non-zero value in the Status field). Therefore, when using on-line reconfiguration the Configurator will not permit changes to certain fields of I/O channel blocks unless specific criteria has been met.

On-line Reconfiguration allows the user to make 'Tentative' edits, as indicated on the Configurator screen, to a running strategy before applying these changes. In on-line reconfiguration mode, the user can edit a running LIN Database using the Configurator, and 'Try' the changes in the instrument. The user can then either 'Apply' the tried changes, making them permanent in the instrument; or 'Untry' the changes (removing the changes from the live instrument, but retaining them at the PC end, so that the changes can be altered using the Configurator before again using the 'Try' command).

Caution

Any changes made directly to a running block cannot be 'Tried/Untried', but are applied immediately (e.g. changing the value of a function block's field).

Note For further information refer to Terminal Configurator section.

5.5 MODBUS TOOLS

This LIN instrument type may be configured as a Modbus Master communicating to one or more Modbus instruments. A LIN instrument may alternatively be configured as a Modbus Slave instrument.

Note This software application supports more than one (up to 3) Modbus Gateway facility configurations.

The Modbus Tools defines the communications between LIN and Modbus instruments, but with additional specific configuration can be used to configure an instrument to communicate via the Profibus protocol, see [Configuring Profibus Communications using Modbus Tools](#).

The Modbus configuration data is defined in a Modbus GateWay File (.gwf). This is downloaded with the LIN Database (.dbf) into a LIN instrument. The data in the .gwf is used to define the transfer of data between LIN and Modbus instruments, or a T2550 operating as a Profibus Slave.

This data defines:-

- The operating mode (i.e. Modbus Master, Modbus Slave, or Profibus Slave)
- The serial line set-up (or TCP)
- The mapping between fields in function blocks and the registers of a Modbus instrument
- How field values are transferred between instruments. For example which Modbus functions to use, the addresses of Modbus registers and the format in which data is to be transferred.

Note If communicating via a Profibus network this instrument can only operate as a Profibus Slave. Specific communications parameters MUST be configured using the Modbus Tools, and the LIN Database MUST contain the GWProfS_CON block. This block references a specified GateWay file, .gwf, used to permit Profibus communications.

5.5.1 Preparing to run Modbus Tools

As the Modbus Tools can be accessed from within the *LINtools* program it requires the same preparation as LINtools, consisting of:

- [Connecting the instrument to a Computer.](#)
- [Creating a Project folder.](#)

The *Modbus Tools Help* (Part no. HA028988) should be referred to for details of Modbus Configuration procedures using the *Modbus Tools*.

5.5.2 Running Modbus Tools

An empty Modbus Tools window can be started via the  Start > ... > LINtools Advanced > MODBUS Tools command. Use the 'Open' command to locate the required Instrument and then select the required file type and finally open.

- Alternatively, simply double-click the LIN MODBUS Database file (.ujg) from the required Instrument folder.

Note The Modbus Tools Help (Part no. HA028988) should be referred to for details of Modbus configuration procedures using the Modbus Tools.

5.5.3 Configuring Profibus Communications using Modbus Tools

This LIN instrument can only operate as a Profibus Slave when communicating via a Profibus network and must be configured using the *Modbus Tools*.

It uses designated Modbus registers in the Modbus GateWay File, .gwf. These registers must be added and configured with the required Profibus Input data, Output data, and Demand Data available from the Tactician LIN Database.

When the registers have been configured, the GateWay file, .gwf, must be downloaded to the Instrument with the LIN database file, .dbf, allowing the instrument to communicate with a Profibus Master device via the Profibus protocol.

If configuring a T2550 as a Profibus Slave using a Profibus configuration tool, the Redundancy Status Word, available in the User Parameter Data section must be set appropriately. When set Off, the cyclic data is returned as configured. When set On, the first Word in the cyclic data is overwritten by the Redundancy Status Word.

If configuring the T2550 to use standard Profibus Slave watchdog function when communicating with a T800, or T940(X) Profibus Master, a copy of the T2550 .gsd file, euro0B29.gsd, must be edited. Open this file using a text editor, e.g. notepad, and add Eurotherm_Watch_Dog_enable, Eurotherm_bWD_Fact_1, and Eurotherm_bWD_Fact_2 parameters to the end of the file. Eurotherm_Watch_Dog_enable = 1 must be set to enable the Watchdog function. Eurotherm_bWD_Fact_1, and Eurotherm_bWD_Fact_2 can be edited in the range 1 to 155, and are multiplied to determine the device Watchdog Timeout value in 10mS units.

To ensure this instrument can successfully communicate with a Profibus Master,

- 1 Create a GWProfS_CON block in the instrument database, and in the *FileName* field enter a name for a Modbus Configuration file. This name refers to both the .ujg, and the .gwf.

Use the context menu to open a related Modbus Configuration file, .ujg. This file can be created and opened now using the context menu, or can be automatically created when the database is saved.

Note The Demand Data table will remain offline until Demand Data is accessed.

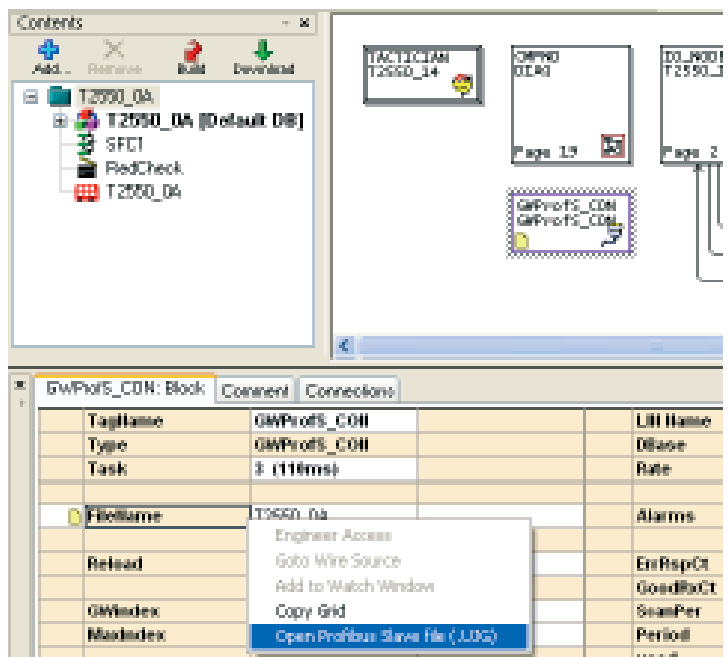

- 2 When the Modbus Tools is open, configure the Operating Mode, and Modbus registers and access the Instrument Options to configure the Communications Protocol and Device Address.
 - the Operating Mode parameters on the Properties page must be set to indicate the instrument is a Slave, communicating via a Serial Network on COM port.

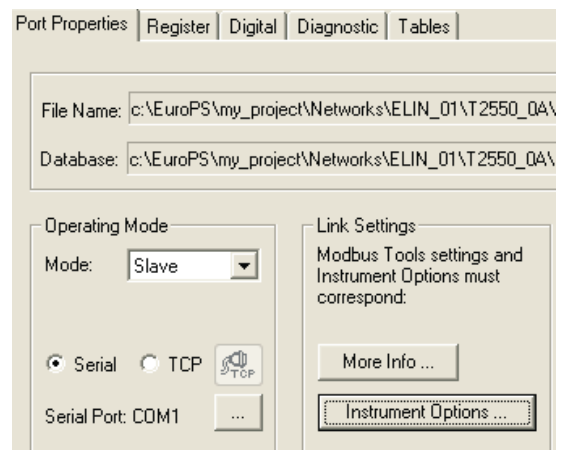

5.5.3 Configuring Profibus Communications using Modbus Tools (Cont.)

- the Instrument Options must be set as shown, i.e.the Serial COM port must be set to Modbus-S, and the Address set appropriately.

Note This sets the Profibus device Address when the Instrument is operating as a Profibus Slave.

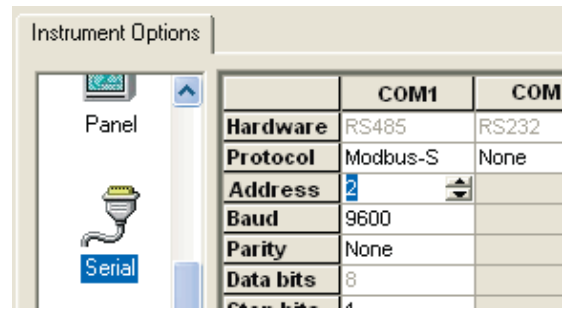

- the Modbus registers must be set at the Offsets shown.

Note It is recommended that Modbus register, Offset 1000, remains unused. This address register is used to transfer the Status word associated with the Profibus Slave device.

- When this configuration is complete, the list of files to download in LINtools MUST include the database file, .dbf, the GateWay file, .gwf, and any file used to support the correct operation of the instrument.

Offset	Field	Format	Decimal Places	Read/Write	Table	Description
0		16 Bit	0	R←W	2	
1		16 Bit	0	R←W	2	
2		16 Bit	0	R←W	2	
3-7						Occupied Registers 3-7 (5)
1000		16 Bit	0	R←W	4	Inputs to Profibus Master
1001	08M01_DA_AI	16 Bit	0	R←W	4	
1002	08M02_DA_AI	16 Bit	0	R←W	4	
1003	08M03_DA_AI	16 Bit	0	R←W	4	
1004	08M01_DA_AI	16 Bit	0	R←W	4	
1005	08M02_DA_AI	16 Bit	0	R←W	4	
1006	08M03_DA_AI	16 Bit	0	R←W	4	
1118	09M01_DA_AI	16 Bit	0	R←W	4	
1119	09M02_DA_AI	16 Bit	0	R←W	4	
1120	09M03_DA_AI	16 Bit	0	R←W	4	
1121	09M04_DA_AI	16 Bit	0	R←W	4	
2000	13M02_DA_AI	16 Bit	0	R←W	5	Outputs to Profibus Master
2001	08M01_DA_AI	16 Bit	0	R←W	5	
2002	08M02_DA_AI	16 Bit	0	R←W	5	
2003	07P02_DA_AO	16 Bit	0	R←W	5	
2004	08Y01_DA_DO	16 Bit	0	R←W	5	
2005	08Y02_DA_DO	16 Bit	0	R←W	5	
2006	08Y04_DA_DO	16 Bit	0	R←W	5	
2007	08Y05_DA_DO	16 Bit	0	R←W	5	
2008	08Y06_DA_DO	16 Bit	0	R←W	5	
2009	08Y07_DA_DO	16 Bit	0	R←W	5	
2010	08Y08_DA_DO	16 Bit	0	R←W	5	
2116	08X02_DA_DI	16 Bit	0	R←W	5	
2117	08X03_DA_DI	16 Bit	0	R←W	5	
2118	08X03_DA_DI	16 Bit	0	R←W	5	
2119	08X04_DA_DI	16 Bit	0	R←W	5	
2120	08X05_DA_DI	16 Bit	0	R←W	5	
2121	08X06_DA_DI	16 Bit	0	R←W	5	
3000	13M01_DA_AI	16 Bit	0	R←W	6	Demand Data
3001	10M01_DA_AI	16 Bit	0	R←W	6	
3002	10M02_DA_AI	16 Bit	0	R←W	6	
3003	11M01_DA_AI	16 Bit	0	R←W	6	
3004	11M02_DA_AI	16 Bit	0	R←W	6	
3005	12P01_DA_AO	16 Bit	0	R←W	6	
3006	12P02_DA_AO	16 Bit	0	R←W	6	
3007		16 Bit	0	R←W	6	

Modbus Register	Description
1000 to 1121	Band of Modbus registers for inputs to Profibus Master from Profibus Slave. Actual size determined by Input table size identified in the euro0B29.gsd file.
2000 to 2121	Band of Modbus registers for Outputs to Profibus Master from Profibus Slave. Actual size determined by Output table size identified in the euro0B29.gsd file.
3000 to 3121	Band of Modbus registers for Profibus Demand Data. The Modbus table relating to Offset 3000 is offline unless Demand Data is actually being accessed.

IMPORTANT To ensure successful Profibus communications, the Demand Data MUST be configured as the first module in the Profibus Configurator.

Table 5.5.3 Modbus registers

CHAPTER 6 CONTROL AND AUTOTUNING

The instrument strategy can be configured to control and tune a control loop, via LINtools Engineering Studio. This chapter discusses the use of the LOOP_PID block, but similar Proportional Band, Integral Time, and Derivative Time, PID, principles are also applicable to the 3_Term block and PID block.

Note Details of each block is described in the LIN Block Reference Manual, Part no. HA 082 375 U003.

Each single loop of control contains two outputs, Channel 1 and Channel 2, that can be configured for PID, On/Off or Valve Position (bounded or unbounded) control. In a temperature control loop Channel 1 is normally configured for heating and Channel 2 for cooling. Descriptions given in this chapter generally refer to temperature control but can also apply to other process loops.

The main topics covered are:

- What is a Control Loop ? (section 6.1)
- LOOP_PID Function Block (section 6.2)
- Effect of Control Action, Hysteresis and Deadband (section 6.3)

6.1 WHAT IS A CONTROL LOOP ?

This is an example of a heat only temperature control loop.

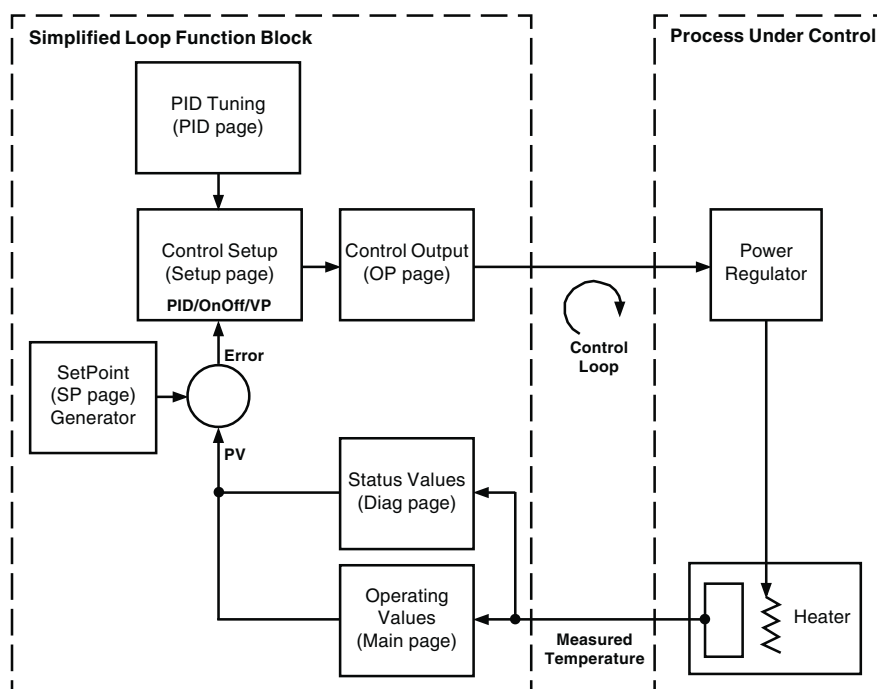

Figure 6-1 Single Loop, Single Channel Control Loop Block schematic

The actual measured temperature, or Process Variable (PV), is connected to the input of the instrument. This PV measurement is compared with a SetPoint (SP, or required temperature). If an error exists between the SP and measured temperature the instrument calculates an output value to call for heating or cooling depending on the process being controlled. In this instrument it is possible to select between a PID, On/Off, Boundless or Bounded Valve Position algorithm. The output(s) from the instrument (OP) are connected to devices in the plant/system, and adjust the heating, or cooling, that results in a change of the PV, that is again measured by the sensor, and the process is repeated. This is referred to as closed loop control.

6.2 LOOP_PID FUNCTION BLOCK

The instrument control loop is configured using the Loop function block and up to 7 (seven) additional Tune_Set blocks, allowing a total of eight sets of tuning parameters for an individual control loop.

Note Each set of PID tuning parameters, one additional set of tuning parameters per Tune_Set block, provides specific tuning for different levels of temperature, particularly useful in control systems where the response to the cooling power is significantly different to that of the heating power.

The LOOP_PID block consists of the following pages

- Main
To setup the operating parameters of the Control Loop. These are an overview of the main parameters such as Auto/Manual select, current PV, current output demand, selected SP value and working SP value.
- Setup
To configure control type for each channel of the selected loop
- Tune
To set up and run the Auto Tune function
- PID
To set up 3 term, Proportional Band, Integral Time, and Derivative Time (PID) control parameters
- SP
To select and adjust different setpoints, setpoint limits, rate of change of setpoint
- OP
To set up output parameters such as limits, sensor break conditions
- Diag
To diagnose Control Loop problems, such as sensor break detection, loop break detection
- Alarms
To setup alarm parameters used to indicate operational extents have been exceeded

Note Parameters are wired using the LINTools Engineering Studio, as part of a strategy, see LIN Block Reference Manual, Part no. HA 082 375 U003, for full block parameter details.

6.2.1 Main page

The Main page of the Loop block provides an overview of parameters used by the overall control loop. It allows,

- Auto or Manual operation to be selected
- To stop the loop from controlling for commissioning purposes
- To hold the integral action
- Read PV and SP values

AUTOMATIC/MANUAL MODE

Each type of control operates differently according to the current operating mode. Automatic indicates that PV is continuously monitored and compared to the SP. The output power is calculated and used to minimise any difference. Manual indicates that the operator controls the output power. The power delivered to the process may be edited directly from the instrument via the User Screen or via the communications network. However, the loop continues to be monitored, allowing a smooth change when Automatic mode is selected.

If On/Off control is configured the output power can be edited by the user but will only allow the power to be set to +100%, 0% or -100%, representing, heat ON/cool OFF, heat OFF/cool OFF, heat OFF/cool ON.

If PID control is configured the output can be edited between +100% and -100%, if cool is configured. The true output value is subject to limiting and output rate limit.

If Valve Position control is configured the raise and lower buttons on a User Screen, configured using the User Screen Editor, will directly control the raise and lower relay outputs during manual operation. By using digital communications it is possible to control the valve by sending nudge commands. A single nudge command, *OP.NudgeUp* or *OP.NudgeDn*, will move the valve by 1 minimum On-Time. In manual mode the natural state will be rest.

Note If sensor break occurs while the control loop is in automatic operation, a configured sensor break output power, *OP.SbrkOP* or *OP.SafeOP* if *Main.Inhibit* is configured, can be output. However, the user can now switch to manual control. In this case manual will become active and the user can edit the output power. On leaving manual, i.e. returning to automatic operation control, the controller will again check for sensor break.

If Auto Tune is enabled, *Tune.Enable* set Yes, while in manual mode, the Auto Tune will remain in a reset state, *Tune.Stage* shows Reset, until the control loop is switched to automatic control, automatically starting the Auto Tune process.

6.2.2 Set Up page

Set Up configures the type of control required for each channel.

TYPES OF CONTROL LOOP

The following control loop types can be configured,

■ On/Off Control

On/Off control is the simplest means of control and simply turns heating power on when the PV, is below SP and off when it is above SP. As a consequence, On/Off control leads to oscillation of the PV. This oscillation can affect the quality of the final product and may be used on non-critical processes. A degree of hysteresis, *Alarms.Hyst*, must be set in On/Off control if the operation of the switching device is to be reduced and relay chatter is to be avoided.

If cooling is used, cooling power is turned on when the PV is above SP and off when it is below.

It is suitable for controlling switching devices such as relays, contactors, triacs or digital (logic) devices.

■ PID Control

PID (Proportional Band, Integral time, and Derivative time), or 3 (Three) Term Control, is an algorithm that continuously adjusts the output, according to a set of rules, to compensate for changes in the PV. It provides more stable control but the parameters need to be set up to match the characteristics of the process under control.

The output from the control is the sum of the contributions from the PID terms. The combined output is a function of the magnitude and duration of the error signal, and the rate of change of the PV.

It is possible to disable the Integral time and Derivative time terms and control the Proportional Band only (P), or Proportional plus Integral (PI) or Proportional plus Derivative (PD).

Note PI control can be used, for example, when the sensor measuring an oven temperature is susceptible to noise or other electrical interference where derivative action could cause the heater power to fluctuate wildly. Whereas, PD control may be used, for example, on servo mechanisms.

In addition to the PID terms described above, there are other parameters that determine the control loop performance. These include Cutback terms, Relative Cool Gain, Manual Reset.

■ Valve Position Control

Valve Position (Motorised Valve) Control is an algorithm designed specifically for positioning motorised valves. It operates in boundless, Valve Positioning Unbounded or bounded mode.

Boundless VP (VPU) control does not require a position feedback potentiometer to operate. It is a velocity mode algorithm that directly controls the direction and velocity of the movement of the valve in order to minimise the error between the SP and the PV. It uses triac or relay outputs to drive the valve motor.

Tip! A potentiometer can be used in boundless mode but can only indicate the actual valve position, and is not included in the control algorithm.

Bounded VP (VPB) control requires a feedback potentiometer as part of the control algorithm.

The control is performed by delivering a 'raise' pulse, a 'lower' pulse or no pulse in response to the control demand signal via relay or triac outputs.

In manual mode operation, Bounded VP controls by the fact that the inner positional loop is still running against the potentiometer feedback, so it is operating as a position loop.

6.2.2 Set Up page (Cont.)

In manual mode operation, BoundlessVP control is an algorithm used as a velocity mode positioner. The algorithm predicts where the valve will move to based on the edit of the manual power. Effectively, when the raise or lower command is activated, the raise or lower output is turned on applying +100% or -100% velocity respectively. It is essential that the motor travel time is correct, so the Integral time can be calculated correctly.

Note Motor travel time is defined as valve fully open – valve fully closed, it is not necessarily the time printed on the motor because if the mechanical stops have been set on the motor, the travel time of the actual valve may be different. Also, if the travel time for the valve is set correctly, the position indicated on the controller will accurately match the actual valve position.

Every time the valve is driven to its end stops, the algorithm is reset to 0% or 100% to compensate for any changes that have occurred due to wear in linkages or other mechanical parts.

This technique makes boundless VP look like a positional loop in manual even though it is not, and enables combinations of heating and cooling, e.g. PID heat, VPU cool and have the manual mode work as expected.

Note Motorised Valve Output configuration will automatically configure the second channel after the first has been setup, e.g. if OP.Ch2Outpt is wired and configured as cooling, OP.Ch1Outpt is automatically wired and configured as heating.

6.2.3 PID page

The PID parameters are used to optimize the control of the loop.

Note If the loop is configured for On/Off Control, only the PID.LBTn is available.

■ Proportional Band, PB

The Proportional Band, PB, or gain, delivers an output that is proportional to the size of the error signal in engineering units or as a percentage of the range. It is the range over which the output power is continuously adjustable in a linear fashion from 0% to 100%, for a heat only control. An error signal below the PB causes an output of 100%, but an error signal above the PB causes an output of 0%.

The width of the PB determines the response to the error signal. If the error signal is too narrow (high gain) the system oscillates by being over responsive, if it is too wide (low gain) the control is sluggish. A control loop is operating at its optimum performance when the PB is as narrow as possible without causing oscillation.

The diagram below shows the effect of narrowing PB to the point of oscillation. A wide PB results in straight line control but with an appreciable initial error between SP and actual temperature. As the PB is narrowed the temperature gets closer to SP until finally becoming unstable.

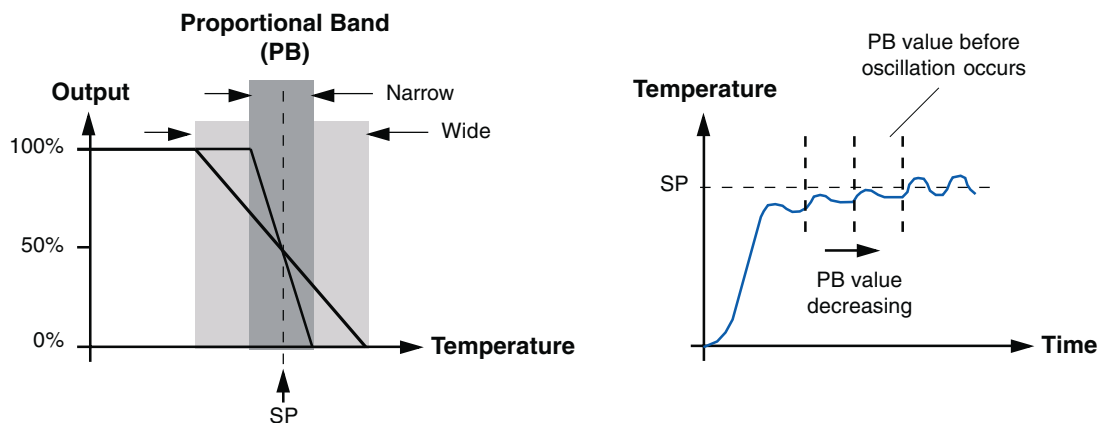

Figure 6-2-3a Proportional Band (PB) configuration

6.2.3 PID page (Cont.)

■ Integral Time, T_i

In Proportional only control, an error between SP and PV must exist for power to be delivered. Integral time, T_i , is used to achieve zero steady state control error.

The T_i term slowly shifts the output level as a result of an error between SP and measured PV. If the measured PV is below SP the Integral time action gradually increases the output in an attempt to correct the error. If it is above SP the T_i action gradually decreases the output or increases the cooling power to correct the error. The diagram below shows the result of introducing T_i action.

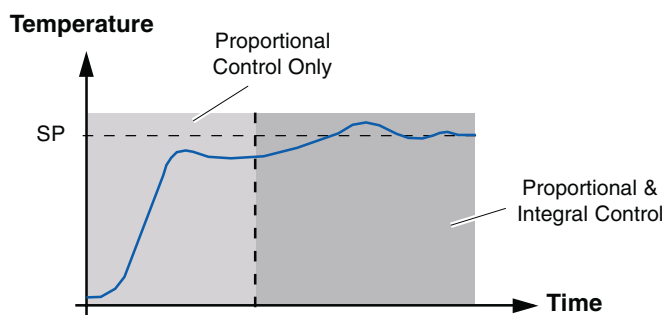

Figure 6-2-3b Integral Time (T_i) configuration

The units for the T_i term are measured in time (1 to 99999 seconds). The longer the T_i constant, the more slowly the output is shifted, resulting in poor response. If the T_i is set too small, it will cause the process to overshoot and even oscillate. The T_i action can be disabled by setting *PID.Tin Off*.

Temporarily disabling the T_i term can be useful when a control loop is expected to open, i.e. it may be necessary to turn heaters off for a short period or switch into manual at low power. In this case it may be an advantage to wire it to a digital input that activates when the heaters are turned off. When the heaters are switched on again the T_i term is already at its previous value minimising overshoot.

In a PID control (3-term control), the T_i term of the PID calculation can be frozen at the current value if *Main.IntHold* is set Yes. It will hold the T_i term at its current value but will not integrate any disturbances in the plant/system. Essentially, this is equivalent to switching to PD control with a manual reset value, T_i term value, preconfigured.

When the control loop is configured to use PID control, changes between manual and automatic can cause abrupt changes to the output value. By configuring Integral Balance, *PID.IntBal*, abrupt changes, bumps, can be prevented, and the output power gradually changed in accordance with the demand from the PID algorithm or by an user via a User Screen.

Note Output bumps can damage valves and destabilise the process.

6.2.3 PID page (Cont.)

■ Derivative Time, Td

Derivative time, Td action, or rate, provides a sudden shift in output as a result of a rapid change in error, whether or not this is caused by PV alone (derivative on PV) or on SP changes as well (derivative on error selection). If the measured PV falls quickly, the Td provides a large change to the output in an attempt to correct the change in error before it goes too far. It is most beneficial in recovering from small error changes.

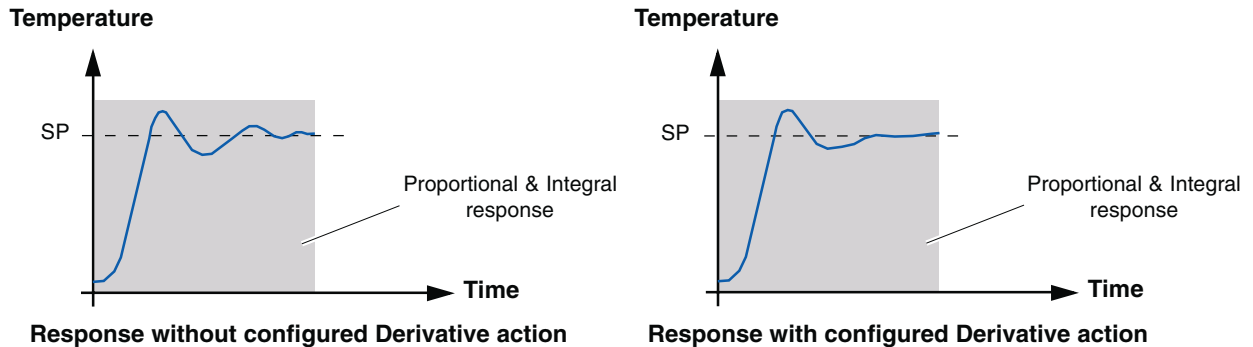

Figure 6-2-3c Derivative Time (Td) configuration

Note A reduction to wear on valve control can be achieved by configuring Td to react to PV changes, whereas, configuring the Td to react to changes to Error, difference between PV and SP, will reduce ramp overshoot, and allows rapid response to small SP changes in temperature control systems.

The Td modifies the output to reduce the rate of error changes. It reacts to changes in the PV by changing the output to remove the errors. Increasing the Td will reduce the settling time of the loop after a change.

Td is often mistakenly associated with overshoot inhibition rather than error response. In fact, Td should not be used to curb overshoot on start up since this will inevitably degrade the steady state performance of the system. Overshoot should be configured using the High and Low Cutback control parameters.

Td is generally used to increase the stability of the loop, however, there are situations where Td may be the cause of instability, e.g. if the PV is noisy, Td can amplify that noise and cause excessive output changes. In these situations it is often better to disable the Td and re-tune the loop. The Td can be disabled by setting *PID.Tdn Off*.

Td can be calculated on change of PV or change of error. If configured on error, changes in the SP will be transmitted to the output. For applications such as furnace temperature control, it is common practice to select Td on PV to prevent thermal shock caused by a sudden change of output as a result of a change in SP.

■ Relative Cool Gain, R2G

The Relative Cool Gain, R2G, is a tuning parameter corresponding to the gain of channel 2 control output, relative to the channel 1 control output.

R2G compensates for the different quantities of power available to heat, as opposed to that available to cool, a process, e.g. water cooling applications might require an R2G value of 0.25 because cooling is 4 times greater than the heating process at the operating temperature.

Note This parameter is set automatically when the Autotune process is performed.

6.2.3 PID page (Cont.)

- High and Low Cutback, CBH and CBL

The CutBack High, *PID.CBH*, and CutBack Low, *PID.CBL*, are values that modify the amount of overshoot, or undershoot, that occurs during large step changes in PV, e.g. under start-up conditions, and are independent of the PID terms. This means that the PID terms can be set for optimal steady state response, while the *PID.CBH* and *CBL* are used to modify any overshoot that may be present.

PID.CBH and *PID.CBL* involves moving the PB towards a cutback point nearest the measured value whenever the latter is outside the PB and the power is saturated, at 0 or 100% for a heat only controller. The PB moves downscale to the lower cutback point and waits for the measured value to enter it. It then escorts the measured value with full PID control to the SP. In some cases it can cause a ‘dip’ in the measured value as it approaches SP, see below, but generally decreases the time needed to bring the process into operation.

The action described above is reversed for falling temperature.

If *PID.CBH* and *PID.CBL* are set to Auto, the values are automatically configured to 3 x PB.

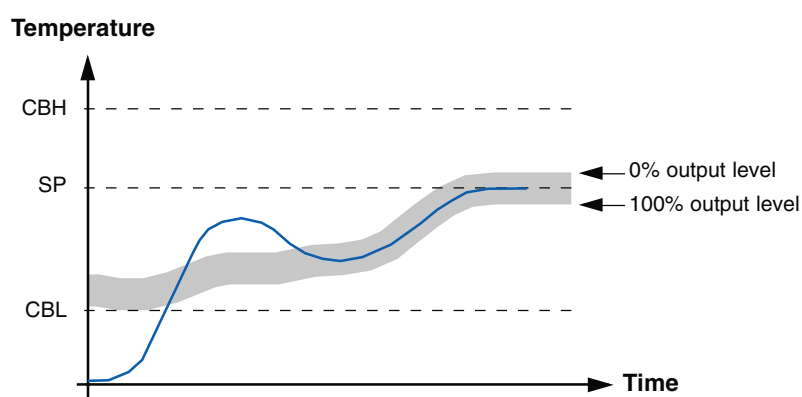

Figure 6-2-3d High and Low Cutback (CBH and CBL) configuration

- Manual Reset, MR

In a PID control (3 Term control), the T_i term automatically removes the steady state error from the SP. If the PID control is changed to PD control, the T_i term will be set to ‘OFF’. Under these conditions the measured value may not settle precisely at SP. The *MR* parameter represents the value of the power output that will be delivered when the error is 0 (zero). To remove the steady state error, the *MR* value must be configured manually.

6.2.3 PID page (Cont.)

■ Loop Break

The term Loop Break is used to show that the PV has not responded to changes in the output, generally within a configured time. The time of response will usually vary between processes, but by configuring the *LBT* (Loop Break Time) tuning parameter, the *Diag.LpBreak* will only show **Yes** if the PV does not respond before this time limit expires.

The *Diag.LpBreak* attempts to detect loss of restoring action in the control loop by checking the control output, the PV and its rate of change. If the PV has not responded to changes in the output within the configured time limit, *PID.LBTn*, a Loop Break has occurred, setting *Diag.LpBreak* to **Yes**. The control action is not affected unless it is specifically wired, in software or hardware, to the control.

Note This must not be confused with Load Failure and Partial Load Failure. The loop break algorithm is purely software detection.

It is assumed that while the requested output power is operating within the output power limits of a control loop, the control loop is operating in linear control and therefore a Loop Break has not occurred. However, if the output becomes saturated, the control loop is operating outside its linear control region, indicating a Loop Break has occurred.

Note If the output power remains saturated at the same level for a significant duration, it could indicate a fault in the control loop. The source of the Loop Break is not important, but the loss of control could have serious consequences.

Since the worst case time constant for a given load is usually known, a worst case time can be calculated using the minimum movement in temperature at the given load. This calculation corresponds to the rate of approach to the SP, and is used to determine that the Loop control will fail at the chosen SP, i.e. if the PV was drifting away from the SP or approaching the SP at a rate less than that calculated, the *Diag.LpBreak* will be set **Yes**.

If an Auto Tune is performed, *LBTn* is automatically set to $T_{in} \times 2$ for PI or PID loop control, and alternatively $12 \times T_{dn}$ for PD loop control. In On/Off control, loop break detection is also based on *LBTn* as $0.1 \times \text{SPAN}$ where $\text{SPAN} = \text{Range High} - \text{Range Low}$. Therefore, if the output is at limit and the PV has not moved by $0.1 \times \text{SPAN}$ in the time configured in *LBTn*, the *Diag.LpBreak* will be set **Yes**.

Note If the time configured in LBTn is 0(off), loop break detection will be disabled.

If the output is in saturation and the PV has not moved by $>0.5 \times P_{bn}$ in the time configured in *LBTn*, the *Diag.LpBreak* will be set **Yes**.

6.2.3 PID page (Cont.)

■ Gain Scheduling

In some processes the tuned PID set can be very different at low temperatures from that at high temperatures particularly in control systems where the response to the cooling power is significantly different from that of the heating power. Gain Scheduling allows a number of PID sets to be stored and provides automatic transfer of control between one set of PID values and another at different operating points of the process. The Loop block includes one set of PID values, but up to an additional 7 (seven) PID sets, one per Tune_Set block can be used. The total number of PID sets used by the control loop is defined in the *PID.NumSets* parameter.

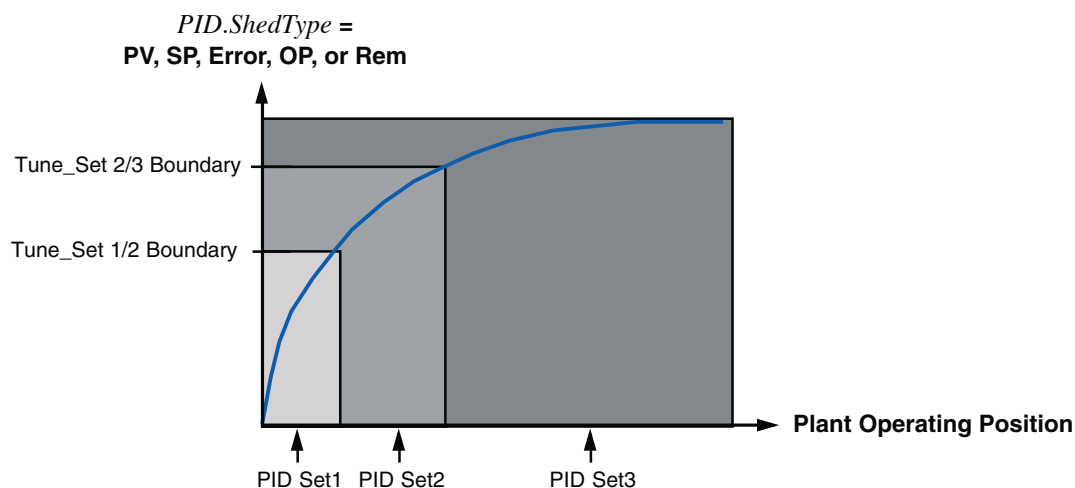

Figure 6-2-3e PID Set boundaries

Gain Scheduling is basically a look up table that can be selected using different strategies or types and provides boundaries, configured in the *Bound* field of each Tune_Set block, that define when the next PID set is used. As the boundary between PID sets is exceeded, under instruction from the Gain Scheduling type defined in *PID.ShedType*, the next PID set is used. The transfer to the next PID set is controlled to stop scheduling oscillation at the boundaries and provides a smooth change between PID sets. The next PID set will start,

- when selected by the operator, if *PID.ShedType* is set to Set. This can also be controlled via the soft wiring within the instrument to allow the operator to select the required PID set remotely.
- when the SP, PV, Error, OP, or Rem value reaches the value configured in the *Bound* field of a Tune_Set block, if *PID.ShedType* is set to SP, PV, Error, OP, or Rem respectively.

Note Auto tune will tune to the active scheduled PID.

6.2.4 Tuning Page

This page is used to automatically configure parameters that are used to set up and run the Auto Tune function.

Tuning involves configuring the Proportional Band, *PB*, Integral Time, *Ti*, Derivative Time, *Td*, CutBack High, *CBH*, CutBack Low, *CBL*, and Relative Cool Gain, *R2G*, parameters, applicable to heat/cool systems only.

The Loop block is added to the strategy with these parameters set to default values. In many cases the default values will give adequate stable straight line control, however, the response of the loop may not be ideal. This is because the process characteristics are fixed by the design of the process, and therefore it is necessary to adjust the control parameters to achieve best control. To determine the optimum values for any particular loop or process it is necessary to carry out a procedure called Loop Tuning.

Caution

If changes are made to the process that affect the Control Loop response significantly, it may be necessary to retune the control loop.

Users have the choice of tuning the loop automatically or manually. Both procedures require the loop to oscillate to provide a control signal.

LOOP RESPONSE

Excluding loop oscillation, loop performance can be described as,

■ Under Damped

In this situation the terms are set to prevent oscillation but do lead to an overshoot of the PV followed by decaying oscillation to finally settle at the SP. This type of response can give a minimum time to SP but overshoot may cause problems in certain situations and the loop may be sensitive to sudden changes in Process Value. This will result in further decaying oscillations before settling once again.

■ Critically Damped

This represents an ideal situation where overshoot to small step changes does not occur and the process responds to changes in control, e.g. PV does not oscillate close to SP.

■ Over Damped

In this situation the loop responds in a controlled but sluggish manner that will result in a loop performance that is not ideal and unnecessarily slow. The balancing of the P, I and D terms depend totally on the nature of the process to be controlled.

Example

In a plastics extruder, a barrel zone will have a different response to a die, casting roll, drive loop, thickness control loop or pressure loop. In order to achieve the best performance from an extrusion line all loop tuning parameters must be set to their optimum values.

6.2.4 Tune Page (Cont.)

INITIAL LOOP BLOCK SETTINGS

In addition to the tuning parameters, there are a number of other parameters that can effect the loop response. Ensure that the following parameters, but not exclusively, are set before any tuning is initiated.

- Setpoint

Before starting a tuning process, the control loop conditions should be set as closely as practicable to the actual conditions that will be met in normal operation, e.g. in a furnace or oven application a representative load should be included, an extruder should be running, etc.

- Heat/Cool Limits

The minimum and maximum power delivered to the process can be limited by the parameters *OP.OutputLo* and *OP.OutputHi*. In heat only control the default values are 0 and 100%, but in heat/cool control the defaults are 100 and 100% only. Although it is expected that most processes will be designed to work between these limits it is possible to limit the power delivered to the process, e.g. if driving a 220V heater from a 240V source the heat limit may be set 80% to ensure that the heater does not dissipate more than its maximum power.

- Remote Output Limits

The *OP.RemOPL* and *OP.RemOPH* parameters must be set within the Heat/Cool Limits, if used.

- Heat/Cool Deadband

In heat/cool control, use the *OP.Ch2DeadB* to set the distance between the heat and cool PBs. The default value is 0%, indicating that the heating will turn off at the same time as cooling turns on. The deadband must be set to ensure that the heat and cool channels will not run at the same time, particularly when cycling output stages are installed.

- Minimum On-Time

If either or both of the output channels is fitted with a relay, triac or logic output, the *OP.NudgeUp* and *OP.NudgeDn* parameters apply the On-Time, for the cycling time of a time proportioning output and should be configured correctly before tuning is started.

- Output Rate limit

This parameter, *OP.RateOP*, is active during tuning and can affect the tuning results.

- Valve Travel Time

If an output is connected to a motor valve positioner, *OP.C1TravT* and *OP.C2TravT* must be configured according to the application.

Before the Tuning process begins, it is recommended

- the tuning process is always started when PV and SP are not in close proximity. This allows start up conditions to be measured and CutBack High, *CBH*, and CutBack Low, *CBL* values to be calculated more accurately.
- the tuning should only be attempted during dwell periods and not during ramp stages. If a control loop is tuned automatically, set *Main.IntHold* to **Yes** during each dwell period while Auto Tune is active. It may be worth noting that tuning, carried out in dwell periods that are at different extremes of temperature can give different results owing to non linearity of heating or cooling. This can provide a convenient way to establish values for Gain Scheduling.
- the *OP.OutputHi* and *OP.OutputLo* parameters are configured, as required. These overall output limit parameters apply during tuning and normal operation.
- the *Tune.HiOutput* and *Tune.LoOutput* parameters are configured, as required. These output power limit parameters apply during the Auto Tune function.

Note The 'tighter' power limit will always apply, e.g. if *Tune.HiOutput* is set to 80% and *OP.OutputHi* is set to 70%, the output power will be limited to 70%. The measured value must oscillate to some degree for the tuner to be able to calculate values. The limits must be set to allow oscillation about the SP.

6.2.4 Tune page (Cont.)

AUTOMATIC TUNING

Automatic tuning operates by switching the output on and off to induce an oscillation in the PV, and calculates the PID tuning parameter values from the amplitude and period of the oscillation. This automatically configures each of the PID parameters with default values.

- Proportional Band, PB
This parameter is not tuned using this process.
- Integral time, Ti, and Derivative, Td
If using PI, PD or P only control, i.e. if Ti and/or Td is set to OFF, disabled, relevant parameters will not be tuned.
- CutBack High, *PID.CBH*, and CutBack Low, *PID.CBL*
These parameters can only be automatically tuned if a specific value, not AUTO, is configured before Auto Tune is started. If *PID.CBH* and/or *PID.CBL* is set to Auto, these parameters will remain at the default value 3 x PB.

Note Auto Tune will never return *PID.CBH* or *PID.CBL* values less than 1.6 x PB.

- Relative Cool Gain, *PID.R2G*
This parameter can only be automatically tuned if the control is configured as heat/cool. The tuning will always limit the calculated *PID.R2G* value to between 0.1 and 10. If the calculated value exceeds this limit, *R2G* remains at its previous value but all other tuning parameters are changed.
- Loop Break Time, *PID.LBT*
The tuning of this parameter depends on the Ti configuration. If Ti is set to OFF, disabled, this parameter is set to 12 x Td, but if Ti is enabled, *PID.LBT* is set to 2 x Ti.

Caution

During automatic tuning faults may occur. If a sensor break occurs, *Diag.SensorB* shows On and *Alarms.SensorB* shows TRUE, the Auto Tune will abort and the instrument will deliver the output power configured in *OP.SbrkOP*. Once the fault has been repaired and the fields cleared, the Auto Tune must be re-started.

Automatic tuning can be performed if more than one PID set is used in the control loop. The calculated PID values will be written to the PID set that is active on completion of the tune. Therefore, the user can tune and write the PID values within the boundaries of the appropriate PID set.

Note If the boundaries are close at the completion of the tune, it is not guaranteed the PID values will be written to the correct set, particularly if *PID.ShedType* shows PV or OP. In this situation the *PID.ShedType* should be set to 'Set' and the 'Active Set' chosen manually.

The Auto Tune algorithm reacts depending on the initial conditions of the plant, i.e. from where PV starts. In a heat/cool, or heat only control loop, automatic tuning can start when PV is,

- below the SP
- at the same value as the SP, i.e. within 0.3% of the range if *Setup.PB_Units* is set to % or ± 1 engineering unit, 1 in 1000, if *Setup.PB_Units* is set to Eng.
- outside the *OP.OutputHi* and *OP.OutputLo* or *Tune.HiOutput* and *Tune.LoOutput* as determined by the tightest parameter values.

6.2.4 Tune page (Cont.)

Tuning from below SP - Heat/Cool control loop

The point that automatic tuning is performed, Tune Control Point, is designed to operate just below the Target SP, Loop block - *Main.TargetSP*, the expected operating value of the process. Using a Tuning Control Point configured below the Target SP ensures the process is not significantly overheated or overcooled and is calculated as,

$$\text{Tune Control Point} = \text{Initial PV} + 0.75 (\text{Target SP} - \text{Initial PV})$$

Note The Initial PV is the PV measured after a settling period of 1 minute.

Example

If Target SP = 500°C and Initial PV = 20°C, the Tune Control Point is calculated at 380°C.

If Target SP = 500°C and Initial PV = 400°C, the Tune Control Point is calculated at 475°C.

Note An overshoot is likely to be less in the second example because the process temperature is already close to the Target SP.

When automatically tuning a heat/cool control loop and the Initial PV is below the SP, a number of cycles are run to calculate the PID tuning parameters.

- i Auto Tune is started, *Tune.Enable* set On (A), but both heating and cooling power remain off for 1 minute (A - B) to allow the algorithm to establish steady state condition, then calculate the Initial PV.
- ii First heat/cool cycle (B - D) establishes the first overshoot used to calculate *PID.CBL* if it is not set to Auto.
- iii Two cycles of oscillation (B - F) are produced to measure the peak to peak response, the true period of oscillation, and calculate the PID terms.
- iv An extra heat stage (F - G) is applied and all power is turned off to allow the plant to respond naturally. During this period the *PID.R2G* is calculated, then *PID.CBH* is calculated using the sum $PID.CBL \times PID.R2G$.
- v Auto Tune is complete, *Tune.Enable* set Off (H). The control loop is now operating at the Target SP using the automatically tuned PID term values.

Note This operation also applies if the Initial PV is above SP, but will start with full cooling applied from (B), and not full heating, as below.

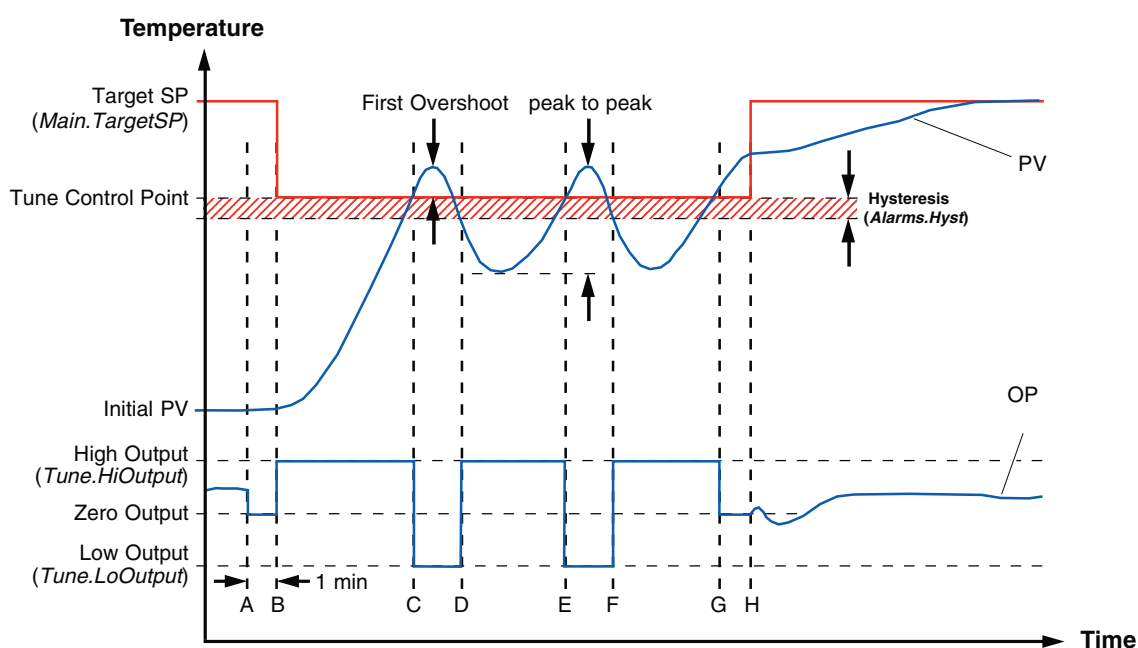

Figure 6-2-4a Tuning from below SP - Heat/Cool control loop

6.2.4 Tune page (Cont.)

Tuning from below SP - Heat only control loop

When automatically tuning a heat only control loop and the Initial PV is below the SP, a number of cycles are run to calculate the PID tuning parameters. The operation is similar to the heat/cool control loop, but because a cooling channel does not exist, it completes prematurely, ignoring the *PID.R2G*.

Note *PID.R2G* is set to 1.0 for heat only control loop

- i Auto Tune is started, *Tune.Enable* set On (A), the heating power remains off for 1 minute (A - B) to allow the algorithm to establish steady state condition, then calculate the Initial PV.
- ii First heat cycle (B - D) establishes the first overshoot used to calculate *PID.CBL* if it is not set to Auto and *PID.CBH* is set to the same value.
- iii Two cycles of oscillation (B - F) are produced to measure the peak to peak response, the true period of oscillation, and calculate the PID terms.
- iv Auto Tune is complete, *Tune.Enable* set Off (F). The control loop is now operating at the Target SP using the automatically tuned PID term values.

Note This operation also applies if the Initial PV is above SP, but will start with full cooling applied from (B), and not full heating, *PID.CBH* is calculated, not *PID.CBL*, and *PID.CBL* is set to the same value as *PID.CBH*. The operation is similar to the heat/cool control loop, but because a cooling channel does not exist, it completes prematurely, ignoring the *PID.R2G*.

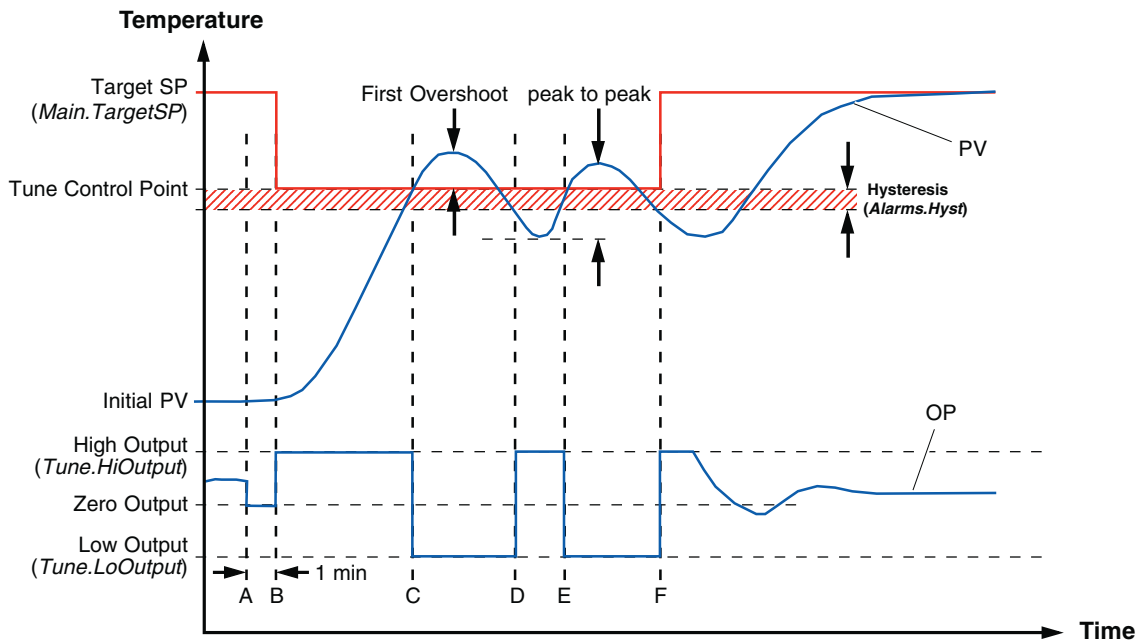

Figure 6-2-4b Tuning from below SP - Heat only control loop

6.2.4 Tune page (Cont.)

Tuning at SP - Heat/Cool and Heat only control loop

When automatically tuning either type of control loop and the Initial PV is configured at the same value as the SP, a number of oscillations are produced to calculate the PID tuning parameters. This operation does not calculate *PID.CBH* and *PID.CBL* because there is not an initial start up response to the application of heating or cooling.

Note *PID.CBH* and *PID.CBL* will never return a value less than $1.6 \times PB$.

- i Auto Tune is started, *Tune.Enable* set On (A). The output is frozen at the current value for 1 minute (A - B), and SP must remain within 0.3% of the range of the control if *Setup.PB_Units* is set to %, Percent, or ± 1 engineering unit (1 in 1000) if set to Eng. Range is defined using the *SP.RangeHi*, and *SP.RangeLo* parameters. If during this period the PV drifts outside these conditions Auto Tune will be aborted, and resumed from above or below SP depending on which way the PV has drifted.

Note A Tune Control Point is not used because the loop is already at SP.

- ii Cycles of oscillation (C - G) are produced by switching the output between the output limits, and are used to measure the peak to peak response, the true period of oscillation, and calculate the PID terms.
- iii An extra heat stage (G - H) is applied and all power is turned off (H) to allow the plant to respond naturally. During this period the *PID.R2G* is calculated.
- iv Auto Tune is complete, *Tune.Enable* set Off (I). The control loop is now operating at the Target SP using the automatically tuned PID term values.

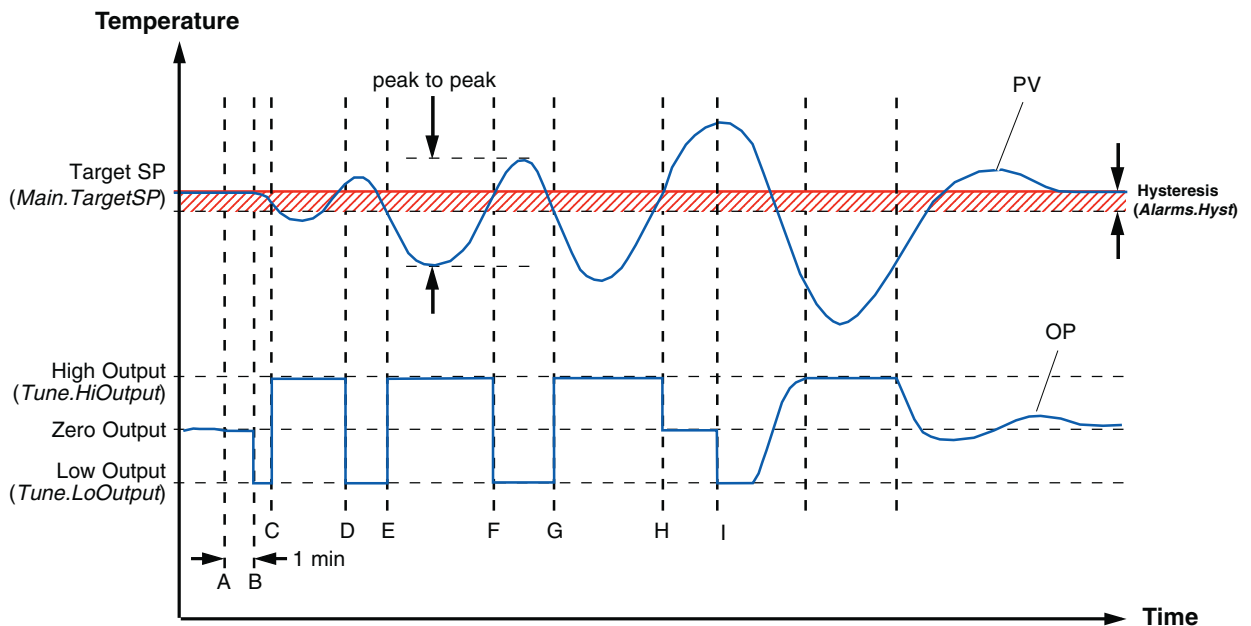

Figure 6-2-4c Tuning from below SP - Heat/Cool and Heat only control loop

6.2.4 Tune page (Cont.)

MANUAL TUNING

If automatic tuning gives unsatisfactory results, the control loop can be tuned manually. There are a number of standard methods for manual tuning, this is the Ziegler-Nichols method.

Note In a heat/cool control loop, channel 2 must be correctly configured for cooling before tuning is started to allow accurate tuning of the PID.R2G.

- i Adjust SP to the normal operating condition. It is assumed this will be above the PV so that heat only is applied.
- ii Set the Integral Time, *PID.Ti*, and the Derivative Time, *PID.Td*, to OFF.
- iii Set CutBack High, *PID.CBH*, and CutBack Low, *PID.CBL*, to Auto. These can be changed later, if required.

Note It is not important that PV does not settle precisely at the SP.

- iv Depending how PV is reacting edit the *PID.PB* value. If PV is stable, reduce and keep reducing *PID.PB* until just before PV starts to oscillate, allowing the loop to settle between each change. Record the *PID.PB* value and the time taken for PV to oscillate. If PV is already oscillating, measure the time taken for PV to oscillate, then increase the *PID.PB* until it just stops oscillating. Record the *PID.PB* value.

*Note The measured time taken for PV to oscillate is used to calculate the *PID.Ti* and *PID.Td* values for manually tuning the control loop, see table below.*

- v Configure the PID values according to the type of control used, see below.

Type of Control	Proportional Band <i>PID.PB</i>	Integral Time <i>PID.Ti</i>	Derivative Time <i>PID.Td</i>
Proportional Only	2 x PB	OFF(Disabled)	OFF(Disabled)
Proportional and Integral	2.2 x PB	0.8 x measured time	OFF(Disabled)
Proportional, Integral and Derivative	1.7 x PB	0.5 x measured time	0.12 x measured time

Tuning the Relative Cool Gain, *PID.R2G*

The *PID.R2G* parameter is used to compensate for the different quantities of energy needed to heat, as opposed to that needed to cool a process.

- i Observe the oscillating PV, an uneven waveform indicates the energy needed for each process is not compensated correctly.
- ii Adjust the *PID.R2G* value to produce a symmetrical waveform showing the energy needed for each process is compensated correctly.
- iii When the waveform is symmetrical, configure the PID values according to the type of control used, see above.

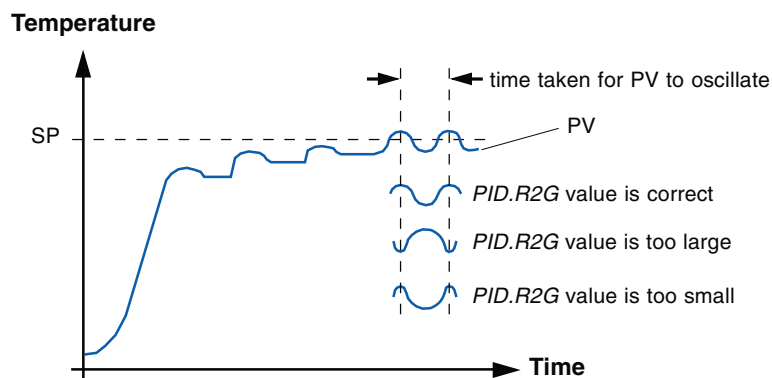

Figure 6-2-4d Relative Cool Gain waveform tuning

6.2.4 Tune page (Cont.)

Tuning the CutBack High, *PID.CBH*, and CutBack Low, *PID.CBL*

The *PID.CBH*, and *PID.CBL* parameters are used prevent unacceptable overshoot and undershoot at startup or large step changes in PV.

- i Adjust SP to the normal operating condition. It is assumed this will be above the PV so that heat only is applied.
- ii Set the Integral Time, *PID.Ti*, and the Derivative Time, *PID.Td*, to provide the optimum steady state control.
- iii Set CutBack High, *PID.CBH*, and CutBack Low, *PID.CBL*, to one proportional bandwidth converted into display units. This is calculated using *PID.PB* defined as a %, percentage, value in

$$PID.CBH \text{ and } PID.CBL = \frac{PB}{100} \times \text{Span of control}$$

Example

If PB = 10% and the Span of the control is 0 - 1200°C, then

$$PID.CBH \text{ and } PID.CBL = \frac{10}{100} \times 1200 = 120$$

If overshoot is observed following the correct settings of the PID terms increase the value of *PID.CBL* by the value of the overshoot in display units. If undershoot is observed increase the value of the parameter *PID.CBH* by the value of the undershoot in display units

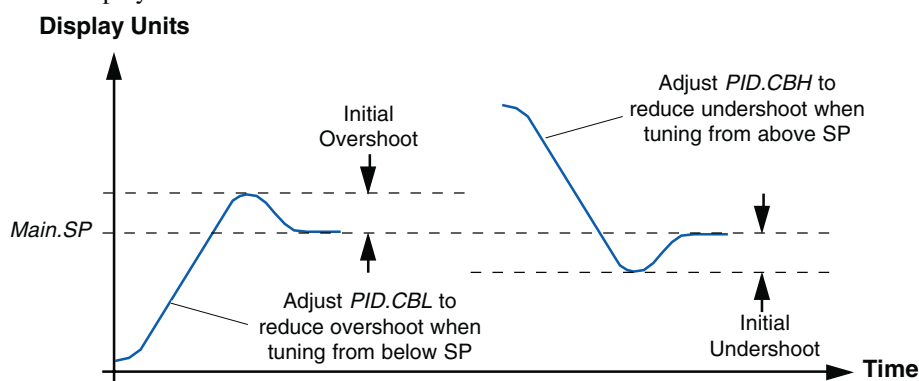

Figure 6-2-4d CutBack High, *PID.CBH*, and CutBack Low, *PID.CBL* waveform tuning

6.2.5 SP page

The SetPoint, SP, page of the Loop block provides parameters for configuring the SP used by the control loop.

The control SP, defined as the Working SetPoint (*Main.WSP*), is the value ultimately used to control the PV in a control loop, and can be derived from,

- *SP.SP1* or *SP.SP2*, can be configured by the user and switched into use by an external signal or via a user interface
- *SP.AltSP*, an external (remote) analogue source

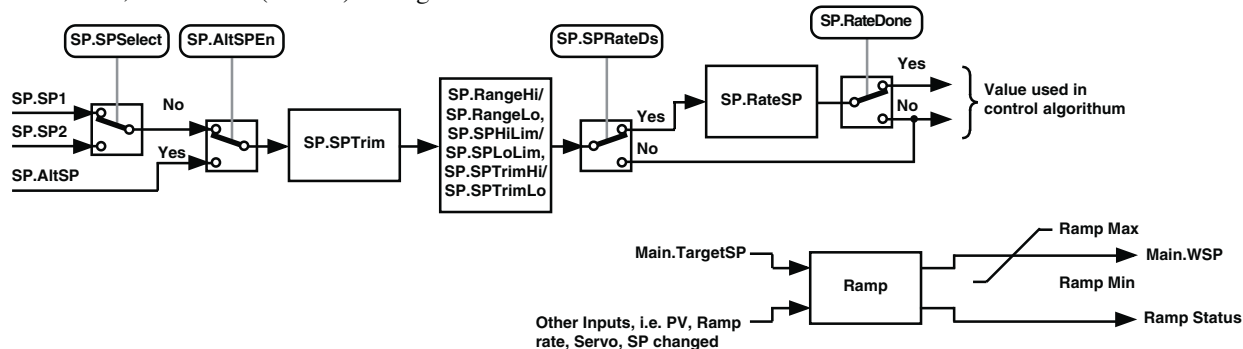

Figure 6-2-5a SetPoint, SP, page block diagram

6.2.5 SP page (Cont.)

When the control loop is configured, changes to the *Main.TargetSP* can cause abrupt changes to the output value. By configuring Setpoint Integral Balance, *SP.SPIntBal*, abrupt changes, bumps, can be prevented, and the output power gradually changed in accordance with the demand by an user via a User Screen.

This page also provides the facility to limit the rate of change of the SP before it is applied to the control algorithm. It will also provide upper and lower SP limits, *SP.SPHiLim* and *SP.SPLoLim*, for the local SPs, *SP.SP1* and *SP.SP2*.

Tip! *SP.RangeHi* and *SP.RangeLo* provides range information for the control loop in the control calculation to generate the Proportional Bandwidth, $\text{Span} = \text{SP.RangeHi} - \text{SP.RangeLo}$. These parameters ultimately affect all SP values.

User configurable methods for tracking are available, providing smooth transfers between SP values and between operational modes.

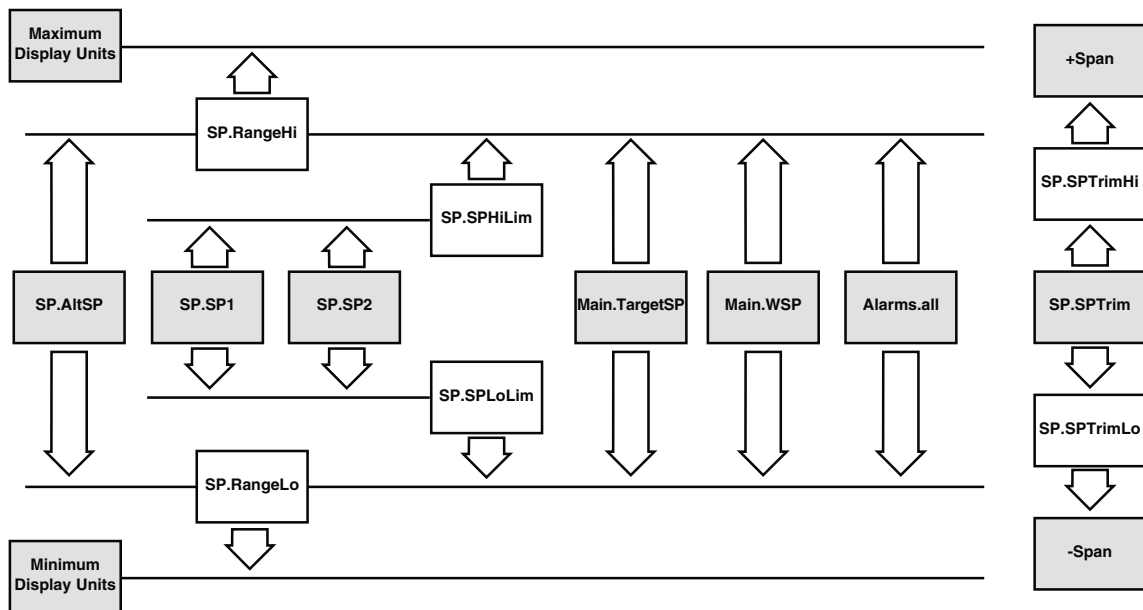

Figure 6-2-5b Setpoint Limits

■ Setpoint Rate Limit, *SP.RateSP*

The Setpoint Rate Limit, *SP.RateSP*, allows the rate of change of SP to be controlled and prevents step changes in the SP. It is a simple symmetrical rate limiter including any configured Setpoint Trim, *SP.SPTrim*, applied to the Working SP, *Main.WSP*. *SP.RateSP* is controlled by Setpoint Rate Limit Disable, *SP.SPRateDS*. If *SP.SPRate* is set Off, any change made to the SP will be effective immediately, but when a value is set any change in the SP will be effected at the value set in units per minute. *SP.RateSP* applies to *SP.SP1*, *SP.SP2* and *SP.AltSP*.

When *SP.RateSP* is active *SP.RateDone* will display **No**. When the SP has been reached the value configured in this parameter, *SP.RateDone* will change to **Yes**, but will be cleared if the Target Setpoint, *Main.TargetSP*, is changed.

When *SP.RateSP* is set to a value, not Off, *SP.SPRateDS* can be used to control, disable and enable, the *SP.RateSP*. This avoids constantly switching this parameter between Off and a value.

Note *SP.RateSP* is suspended and *Main.WSP* is set to 0 (zero) if the PV is in sensor break, *Diag.SensorB* set Yes and *Alarms.SBreak* set TRUE. When the sensor break is cleared, *Main.WSP* returns to the defined SP at the configured *SP.RateSP*.

6.2.5 SP page (Cont.)

- Setpoint Tracking, SP.SPTrack

Setpoint Tracking, *SP.SPTrack*, ensures the Local SP, *SP.SP1* or *SP.SP2*, adopts the Alternate Setpoint, *SP.AltSP*, value when switching from *SP.SP1* or *SP.SP2* to *SP.AltSP* to maintain bumpless transfer when returning to *SP.SP1* or *SP.SP2*. Bumpless transfer does not take place when changing from Local to Remote.

Note If a *SP.RateSP* value is configured, the SP will be effected at the value set in units per minute when changing from *SP.SP1* or *SP.SP2* to *SP.AltSP*.

The SP used by the control can be derived from,

- local SPs, *SP.SP1* or *SP.SP2*. These can be selected via *SP.SPSelect*, digital communications or by a digital input that selects *SP.SP1* or *SP.SP2*, e.g. to switch between normal running conditions and standby conditions. If *SP.RateSP* is set OFF, the new SP value is adopted immediately when the switch is changed.
- a Remote analogue source. The source could be an external analogue input into an analogue input module wired to *SP.AltSP* or a User Value wired to *SP.AltSP*. The Alternate Setpoint, *SP.AltSP*, is used when the *SP.AltSPEn* shows **Yes**.

- Manual Tracking

When the control loop is operating in manual mode the currently selected SP, *SP.SP1* or *SP.SP2*, tracks the PV. When the control loop resumes automatic control there will be no step change in the resolved SP. Manual tracking does not apply to the Alternate Setpoint, *SP.AltSP*.

- Servo to PV

After power cycling the instrument, the time taken to obtain the *Main.WSP* can be increased by configuring *SP.ServToPV*. When *SP.ServToPV* shows On, the measured PV, *Main.PV*, is used as a start point for the *Main.WSP*. This decreases the time required for the *Main.WSP* to arrive at the *Main.TargetSP*.

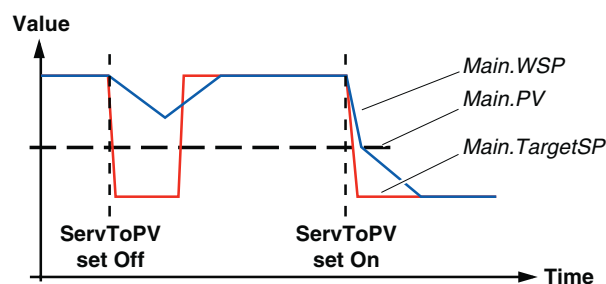

Figure 6-2-5c PV starting point

6.2.6 OP page

The Output, OP, page of the of the Loop block provides parameters for output control algorithms and manages the output in exception conditions, i.e. start up and sensor break. It selects the correct output sources to be used, determines the heat or cool operation and then applies limits. Power FeedForward and non-linear cooling are also applied. The outputs, *OP.Ch1Outpt* and *OP.Ch2Outpt*, are normally connected to an output module and converted into an analogue or time proportioned signal for electrical heating, cooling or valve movement. These parameters are limited using the upper and lower output limits, *OP.OutputHi* and *OP.OutputLo*. The following additional configuration may also be required,

- Individual output limits can be configured for each set of PID parameters when gain scheduling is used.
- The *Diag.SchdOPHi* and *Diag.SchdOPLo* can be set to values that override the gain scheduling output values.
- A limit can be applied from an external source, derived from *OP.RemOPH* and *OP.RemOPLo*, Remote output high and Remote output low. These parameters are wireable, e.g. they can be wired to an analogue input module so that a limit can be applied through some external strategy. However, if these parameters are not wired, $\pm 100\%$ limit is applied every time the instrument is powered up.
- The tightest set, between Remote and PID, is connected to the output if an overall limit is applied using parameters *OP.OutputHi* and *OP.OutputLo*.
- *Diag.WrkOPHi* and *Diag.WrkOPLo* read only parameters showing the overall working output limits.

Note The tune limits are a separate part of the algorithm and are applied to the output during the tuning process. The overall limits *OP.OutputHi* and *OP.OutputLo* always have priority.

6.2.6 OP page (Cont.)

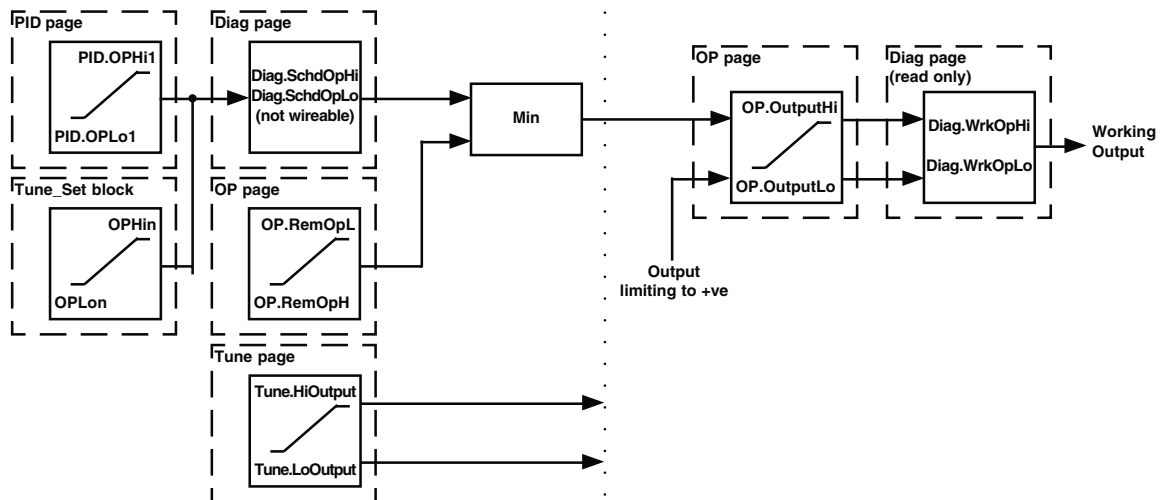

Note Each OPHin and OPLon are derived from a Tune_set block identified by the n, where n equals the PID set number.

Figure 6-2-5a Output Limits

■ Output Rate Limit, OP.RateOP

The Output Rate Limit, *OP.RateOP*, allows the rate of change of OP to be controlled and prevents step changes in the OP. It is a simple symmetrical rate limiter applied to the Working OP, *Main.WrkOP*, and remains active while the control loop is operating in manual mode. The *OP.RateOP* is performed by determining the direction the output is changing, and incrementing or decrementing the Working Output, *Main.WrkOP*, until *Main.WrkOP* is equal to the required Target Output, *Diag.TargetOP*.

The incremental or decremental value is calculated based on the sampling (update) rate of the algorithm, i.e. 110ms, and the configured *OP.RateOP* value. Any change in output less than the rate limit increment will take effect immediately. The direction and increment is calculated on every execution of the rate limit. Therefore, if the rate limit is changed during execution, the new rate of change will take effect immediately. If the output is changed while rate limiting is taking place, the new value will take effect immediately in the direction of the rate limit and in determining whether the rate limit has completed.

Note The *OP.RateOP* is self-correcting, i.e. if the increment is small and is lost in the floating point resolution, the increment will be accumulated until it takes effect.

OP.RateOP is controlled by Output Rate Limit Disable, *OP.RateDis*. If *OP.RateOP* shows Off, any change made to the OP will be effective immediately, but when a value is set any change in the OP will be effected at the rate set in %, per cent, per second.

When *OP.RateOP* is set to a value, not Off, *OP.RateDis* can be used to control, disable and enable, the *OP.RateOP*. This avoids constantly switching this parameter between Off and a value.

■ Sensor Break Mode, OP.SbrkMode

The Sensor Break Mode, *OP.SbrkMode*, determines the response of the control loop when a Sensor Break occurs. When a Sensor Break is detected by the measurement system, *Diag.SensorB* shows On and *Main.Alarms.Sbreak* set TRUE, the output can be configured to go to a pre-set value, defined by *OP.SbrkOP*, or remain at its current value, *OP.SbrkMode* set Hold.

When *OP.SbrkMode* shows SbrkOP, the output will ramp to the *OP.SbrkOP* value at the rate defined in *OP.RateOP*, unless *OP.RateOP* shows Off causing the output to step to the *OP.SbrkOP* value. When *OP.SbrkMode* shows Hold, the output of the loop will stay at its last good value. If an *OP.RateOP* value, not Off, has been configured a small step may be seen, because the *Main.WrkOP* will limit to the 2 second old value.

When a Sensor Break has been cleared, the power output will ramp from the current value and transfer smoothly to the control value.

6.2.6 OP page (Cont.)

■ Forced Output, OP.ForcedOP

A Forced Output, *OP.ForcedOP*, is a manually defined control loop output value adopted when switching from automatic control, *Main.AutoMan* shows Auto, to manual control, *Main.AutoMan* shows Man. By default, the output power is maintained and can be edited by the user. An OP value can be automatically applied after power cycling by defining the source using the *OP.ManStart*. When the *OP.ManStart* parameter is set On, *OP.ManMode* is used to define the source of power applied at startup, but if set Off the source of power applied depends on *Main.AutoMan*.

When the control loop output switches to manual mode, *Main.AutoMan* shows Man, the current *Diag.TargetOP* value steps, *OP.ManMode* shows Step, to the output value derived from *OP.ForcedOP*. If *OP.ManMode* shows Track or LastMop, the *OP.ForcedOP* value is not affected.

Note If *OP.ManMode* shows Track, and *OP.TrackEN* shows On, *OP.ManOP* is derived from a value tracking the *Main.WrkOP* during automatic control, providing a bumpless transfer to manual mode. Any subsequent edits to the *Diag.TargetOP* are tracked back into *OP.ManOP*. If *OP.ManMode* shows LastMOP, the *OP.ManOP* value uses the last value configured by the user.

■ Power FeedForward, OP.PwrffEnb

Power FeedForward is used to drive a heating element. It monitors the line voltage and compensates for fluctuations before they affect the process temperature, providing better steady state performance when the line voltage is not stable. It is mainly used for digital type outputs that drive contactors or solid state relays.

Power FeedForward is only applicable to a heating application and can be controlled by Power FeedForward Enable, *OP.PwrffEnb* shows On.

Note *OP.PwrffEnb* can be set Off, for any non-electric heating process or when analogue thyristor control is used because compensation for power changes is included in the thyristor driver..

Example

Consider a process running at 25% power, with zero error and then the line voltage falls by 20%. The heater power would drop by 36% because of the square law dependence of power on voltage. A drop in temperature would result. After a time, the thermocouple and control loop would detect this fall and increase the On-Time of the contactor just enough to bring the temperature back to SP. Meanwhile, the process would be running a bit cooler than optimum that can cause some imperfection in the product.

With Power Feed Forward enabled, *OP.PwrffEnb* shows On, the line voltage is monitored continuously and On-Time increased or decreased to compensate immediately. This prevents any temperature disturbance caused by a line voltage change.

Note Power FeedForward and Feed Forward are not the same.

6.2.6 OP page (Cont.)

■ Cooling Algorithm, *OP.CoolType*

Cooling Algorithm, *OP.CoolType*, is used to define the method of cooling a system that can vary between applications.

Example

An extruder barrel can be cooled by forced air from a fan, or by circulating water or oil around a jacket. The cooling effect is different depending on the method. The cooling algorithm can be set to linear where the control output changes linearly with the PID demand signal, or it can be set to water, oil or fan where the output changes non-linearly against the PID demand. The algorithm provides optimum performance for these methods of cooling,

- Oil Cooling. Being non-evaporative, oil cooling is pulsed in a linear manner. It is a deep and direct cooling method and needs a lower heat cool gain, *PID.R2G*, than fan cooling
 - Water Cooling. Water cooling does not operate well in areas running well above 100°C. The first pulses of water will flash off into steam giving a greatly increased cooling capacity due to the latent heat of evaporation. When the area settles down, less or even no evaporation is possible and the cooling is less severe. The Water cooling algorithm compensates for the transition out of the initial strong evaporative cooling.
 - Fan Cooling. This is much gentler than water cooling and not so immediate or decisive because of the long heat transfer path through the finned aluminium cooler and barrel. With fan cooling, a heat cool gain, *PID.R2G*, setting of 3 upwards would be typical and delivery of pulses to the blower would be linear, i.e. the On-Time would increase proportionally with percentage cool demand.
- FeedForward,

FeedForward is a scaled value that is added to the PID output, before any limiting. It can be used for the implementation of cascade loops or constant heat control. FeedForward is implemented such that the PID output is limited to trim limits, *OP.FFTrimLm*, and acts as a trim on a FeedForward value, *OP.FFOP*. The *OP.FFOP* is derived from the PV or SP, *OP.FFType* shows PV or SP, by scaling the PV or SP by the *OP.FFGain* and *OP.FFOffset*. Alternatively, if *OP.FFOP* shows Remote, a remote value will be used for the *OP.FFOP*, this is not subject to any scaling. The resultant *OP.FFOP* is added to the limited PID OP and becomes the PID output as far as the output algorithm is concerned. The feedback value that is generated must have the *OP.FFOP* removed before being used again by the PID algorithm, as shown below.

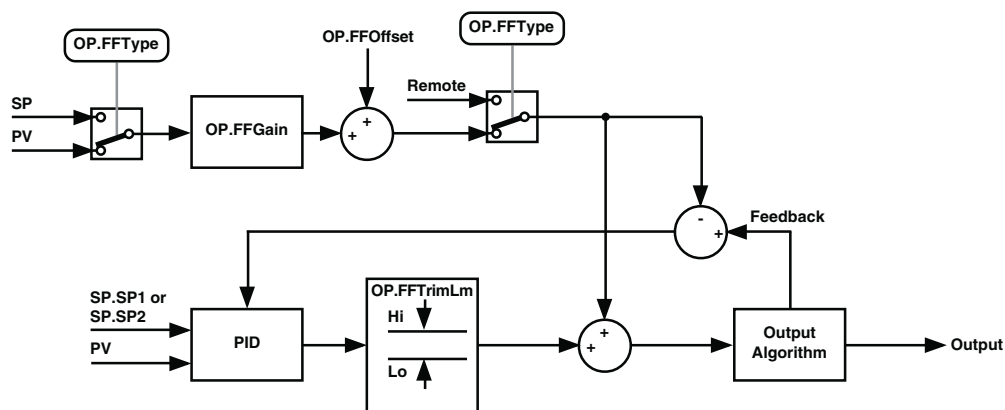

Figure 6-2-5b FeedForward block diagram

6.2.7 Diag page

The Diagnostic, Diag, page of the Loop block provides parameters that assist the commissioning of the control loop. These parameters are generally read only, but can be wired from to produce an application specific strategy, e.g. *Diag.LpBreak* can be wired to an output module to produce a physical output if the Loop Break Time, *PID.LBT*, is exceeded.

Additional gain scheduling parameters are also provided. These display the current values of the control time constants as set by the active PID list and determined by Gain Scheduling.

6.2.8 Alarms page

The Alarms page of the Loop block provides parameters that define the alarm limits applied during the operation of the control loop and will help during commissioning.

- High High Absolute, High Absolute, Low Absolute and Low Low Absolute, *Alarms.HiHi*, *Alarms.Hi*, *Alarms.Lo*, and *Alarms.LoLo*

A High High Absolute, High Absolute, Low Absolute and Low Low Absolute value, displayed in engineering units, define the limits of the process. If the configured value is exceeded the corresponding alarm field is set TRUE, i.e. *Main.Alarms.Hi* shows TRUE, if PV exceeds an *Alarms.Hi* set at 90. The configured Hysteresis value will be applied.

- High Deviation and Low Deviation, *Alarms.DevHi*, and *Alarms.DevLo*

A High Deviation and Low Deviation (*Error*) value, displayed in engineering units, define the limits that PV can deviate from SP before asserting an alarm, *Main.Alarms.DevHi* or *Main.Alarms.DevLo*. The configured Hysteresis value will be applied.

- Hysteresis, *Alarms.Hyst*

A hysteresis value, displayed in engineering units, is applicable to the High Absolute and Low Absolute Alarm limits and the High Deviation, Low Deviation (*Error*) Alarm limits. This value provides a band that defines when the alarm limits are set TRUE. Once an alarm has been annunciated, it is not cleared until the value causing the alarm has returned inside the limit by an amount specified by this parameter.

HiHigh, High, & Low, LoLow. High High, High, and Low Low, Low alarm levels. The action of these four multipurpose parameters depends on which type of alarm function is selected (via the *Type* parameter):

- **Absolute Alarms.** Alarms are set if the block input *PV* moves outside defined levels:

HiHighAl = TRUE when $PV > HiHigh$
HighAl = TRUE when $PV > High$
LowAl = TRUE when $PV < Low$
LoLowAl = TRUE when $PV < LoLow$

An alarm is not reset immediately *PV* returns to the alarm level - *PV* must be inside the level by a margin equal to the *Hyst* parameter before the alarm resets. This hysteresis permits clean transitions into and out of the alarm condition.

- **Deviation Alarms.** The high alarms are set when the positive deviation exceeds the defined levels. The low alarms are set when the negative deviation exceeds the levels:

HiHighAl = TRUE when $(PV - SetPoint) > HiHigh$
HighAl = TRUE when $(PV - SetPoint) > High$
LowAl = TRUE when $(SetPoint - PV) > Low$
LoLowAl = TRUE when $(SetPoint - PV) > LoLow$.

Hysteresis is applied to deviation values as it is to *PV* in absolute alarms.

6.3 EFFECT OF CONTROL ACTION, HYSTERESIS AND DEADBAND

6.3.1 Control Action, Setup.CtrlAct

When configuring temperature control *Setup.CtrlAct* should be set to Rev. If using PID control this means the heater power decreases as the PV increases, but if using on/off control, output 1, usually heat, will be on, 100%, when PV is below the SP and output 2, usually cool, will be on when PV is above the SP.

6.3.2 Hysteresis, Alarms.Hyst

Hysteresis applies to on/off control only and is set in the units of the PV. In heating applications the output will turn off when the PV is at SP. It will turn on again when the PV falls below SP by the hysteresis value, see below.

Hysteresis is used to prevent the OP from oscillating at the control SP. If Hysteresis is set to 0, any change in the PV when operating at SP will change the OP, possibly causing unacceptable oscillations. Hysteresis should be set to a value that provides acceptable life for the output contacts, but does not cause unacceptable oscillations in the PV.

Note If this performance is unacceptable, it is recommended that you try PID control.

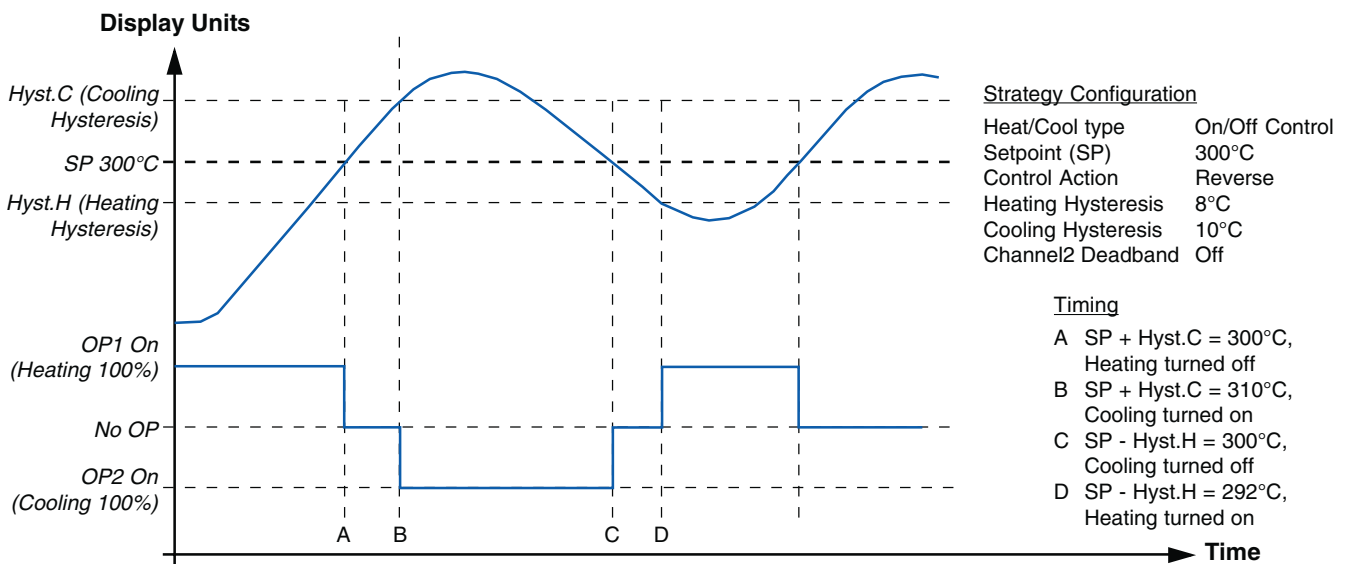

Figure 6-2-6a Hysteresis applied, Deadband not applied

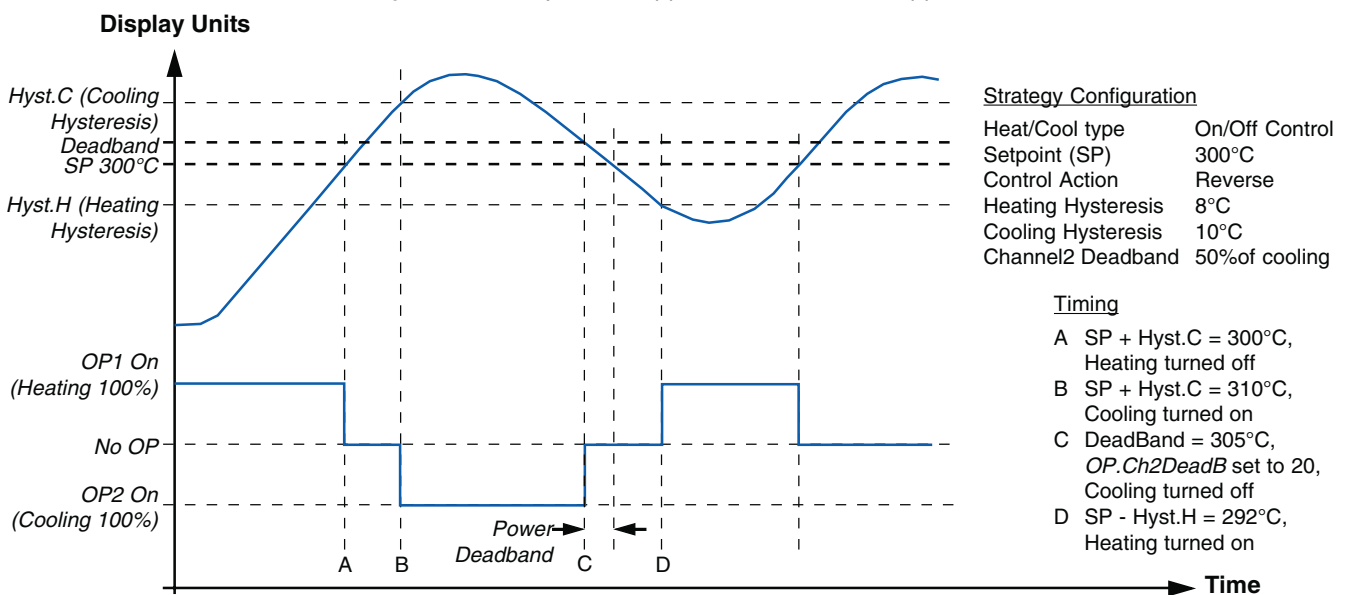

Figure 6-2-6b Hysteresis applied at 5%, Deadband applied at 50%

6.3.3 Deadband, OP.CH2DeadB

Channel 2 Deadband, *OP.CH2DeadB*, can operate on both on/off control or PID control. When used in these control types it has the effect of widening the period when no heating or cooling is applied. However, in PID control its effect is modified by both the *PID.Ti* and *PID.Td*.

OP.CH2DeadB is expected to be used in on/off control only. However, it can be used in PID control when actuators take time to complete their cycle, ensuring that heating and cooling are not being applied at the same time, see previous diagram.

CHAPTER 7 TASK ORGANISATION AND TUNING

The first section of this chapter describes these various software functions (tasks) and their scheduling within the instrument. The next section describes user tasks and their associated block servers. User Task software structure and block server operation is also outlined, as is User Task Tuning, by varying minimum repeat rates, is described.

The main topics covered are:

- Task Scheduling ([section 7.1](#))
- User Tasks ([section 7.2](#))
- User Task Tuning ([section 7.3](#))
- Data Coherence ([section 7.4](#))

7.1 TASK SCHEDULING

All in-built and user-programmed instructions are performed serially, i.e. one at a time.

7.1.1 Tasks

A Task is a unit of software that is responsible for carrying out particular duties at certain times, usually while the LIN Database is running. There are 24 recognisable Tasks in the T2550 instrument. Most Tasks are fixed and cannot be varied by the user. Others, the user tasks, are programmable, see [User Tasks](#).

7.1.2 Priorities

Each task has a priority based on its importance to efficient and safe operation. Priorities are numbered from 1 (highest) to 24 (lowest). A task, once started, will run to completion unless it is interrupted at any time by a task of higher priority. In this case the lower priority task suspends activities until the higher priority Task has finished, at which point it resumes running. These interruptions are hierarchical; several Tasks may be held in suspension by higher priority Tasks at any one time.

7.1.3 Functions

A list of Task functions is given in [Table 7.1.3](#), below.

The following 6 tasks are the block servers and are under the control of the configuration engineer.

USER TASKS 1 TO 4

These are responsible for running up to four user tasks. User Task 1, Fast I/O task (10ms) and User Task 3, Slow I/O Task (110ms) are synchronised to the I/O modules and are module type specific, see [Table 1.3.1](#). The associated I/O blocks can be assigned to User Task 1 or User Task3, as applicable.

Note Any blocks added to the database are automatically assigned to User Task 3 by default. However, the SFC_CON block must always operate on User Task 4.

CACHE SYNC SERVER

This Task is used to maintain synchronisation of cached blocks. The task is repeat driven every 110 msec, but this may be extended depending on the available CPU time available after servicing User Tasks.

CACHE CONN SERVER

This Task is responsible for processing LIN field writes into and out of cached blocks. The task is repeat driven every 110 msec, but this may be extended depending on the available CPU time available after servicing User Tasks.

7.1.3 TASK FUNCTIONS (Cont.)

Task	Schedule	Function
1 Tick	Every 5 msec	Provides system check.
2 Rx_ICM	Event driven	Processes messages received over the ICM.
3 Rx_LIN	Event driven	Processes messages received over the LIN.
4 ICM_Mgr	Every 50 msec	Monitors ICM link low level status. Applies timeouts to transmitted messages. Reprograms ICM hardware if errors are detected
5 PRMT	Event driven (<100msec)	Process Redundancy Management Task. Responsible for effecting and maintaining synchronisation between redundant processors.
6 Pr_Rx	Every 100 msec (approx.)	Processes message received using ELIN via Port Resolution Protocol (PRP).
7 EDBserv (X2)	Every 10 msec (approx.)	Manages ELIN communications with external databases via cached blocks.
8 Network	Event driven	'Housekeeping' for all transactions over the LIN.
9 File Sync	Event driven	Responsible for maintaining synchronisation of filing systems on redundant systems.
10 Mod_Rx	Event driven	Processes messages received via GW Modbus.
11 ModServ	Periodic	Modbus database management.
12 User Task (x4)	Every TaskRptn secs	Runs User Task 1 and User Task 3 synchronised to the fast and slow I/O task modules respectively. Both User Tasks run at an integer multiple (³¹) of the repeat rate, i.e. User Task 1 runs at N * 10ms, and User Task 3 runs at M * 110ms, where N and M are ³¹ . User tasks 2 to 4 run at a repeat rate set in header block.
13 Cache Sync Server	Min. default 100 msec	Responsible for maintaining synchronisation of cached blocks.
14 Cache Conn Server	Min. default 100 msec	Responsible for connections into cached blocks (i.e. LIN network field writes)
15 LLC	Every 100 msec (approx.)	Monitors LIN link low level status. Applies timeouts to transmitted messages. Re-programs LIN hardware if errors are detected.
16 NFS	Event driven	Network Filing system. Processes LIN filing requests.
17 TTermcfg	Event driven	Runs the Terminal Configurator accessed via a Telnet session.
18 Pr_Maint	Every 500 msec (approx.)	PRP database management.
19 Load	Event driven	Loads a database on remote request.
20 Panel	Event driven	Runs the Human Machine Interface.
21 Config	Event driven	Runs the Terminal Configurator via the serial port
22 BatLoad	Event driven	Responsible for batch load operations (e.g. loading or unloading an SFC).
23 Bgnd (scan)	Event driven	Collates alarm information. Performs database checksum testing.
24 Idle	Event driven	'Null task'. Provides environment for CPU execution, whilst no other tasks run.

Table 7.1.3 Task scheduling

7.2 USER TASKS

7.2.1 Terminology

USER TASK

A User Task is a defined set of function blocks in a database that are updated at a specific tick rate. This is normally associated with instrument control.

BLOCK SERVER

A Block Server is a fixed software task, within the T2550 instrument, that executes a User Task, or processes cached blocks.

7.2.2 Execution times

User Task execution times are repeat driven, User Task 1 (reserved for future use), and User Task 3 are synchronised to the fast and slow I/O task modules respectively. Both running at an integer multiple (³1) of the repeat rate, i.e. User Task 1 runs at $N * 10\text{ms}$, and User Task 3 runs at $M * 110\text{ms}$, where N and M are ³1.

User task 1 has the highest priority, followed (in descending order) by User Task 2, User Task 3 and User Task 4 (lowest priority).

Note All I/O blocks for any I/O module must be configured to User Task 3.

Each of the 4 User Tasks has a 'requested repeat rate'. This can be configured using LINtools (Task n Period dialog) or the Terminal Configurator (Block Full Description page).

All function blocks have a Task field, used to allocate each function block to one of the four available User Tasks. This field may also be used to configure the 'requested repeat rate' of the User Tasks. If the 'requested repeat rate' is changed via a function block allocated to a particular User Task, this change is made to the User Task, NOT the function block, and affects all other function blocks assigned to that User Task.

If using the LINtools Database Editor, selecting the Task field from the function block Object Properties Pane reveals the Task dialog. This dialog permits changes to the Task No. allocated to the function block. To enable changes to the Task Period, which is changes to the 'requested repeat rate', click the right (next) arrow button to display the Task Period dialog.

If the requested repeat rate is not configured (LINtools Task n Period dialog or Terminal Configurator Rate ms field set to 0) the default request repeat rate is applied, 10ms for User Task 1 and User Task 2, and 110ms for User Task 3 and User Task 4.

Note Do not configure any Task to a faster requested repeat rate than any higher priority task. Any such configuration will be ignored by the T2550 instrument, but will be run according to the rules stated in [Initialiting repeat rates section](#).

7.2.3 User task block servers

BLOCK SERVER INTERACTIONS

There are six block servers in the T2550 instrument, one for each of the User Tasks, and two for the cached blocks (see Table 7.1.3). The block servers are prioritised, repeat-rate driven, and fully coherent, see Data Coherence section. The T2550 instrument’s block structured LIN Database supports cached blocks by showing local ‘image’ of a remote function block, i.e. a function block running in another instrument on the LIN. The cached function block allows interaction with the remote function block. In a cached function block, the DBase field specifies the name of the remote LIN Database containing the ‘real’ function block.

Block Server 1 has the highest priority, and block server 6 the lowest. Interruption of one block server by another of higher priority, see Priorities section. The User Task block servers will only start at intervals specified by the corresponding Task repeat rate. If the task continues beyond the task repeat time, it will be suspended until the next task repeat time, e.g. User Task 1 is set to repeat every 10 ms, but lasts 10.25 ms, it will start again at the next scheduled repeat time.

Note User Task 1 is reserved for future use. User Task 3 is synchronised with the I/O modules and will start every 110ms. Refer to Table 1.3.1.

Figure 7.2.2a shows schematically how the block servers interact with each other according to their priorities. The darker bars represent running tasks and the paler bars represent suspended tasks.

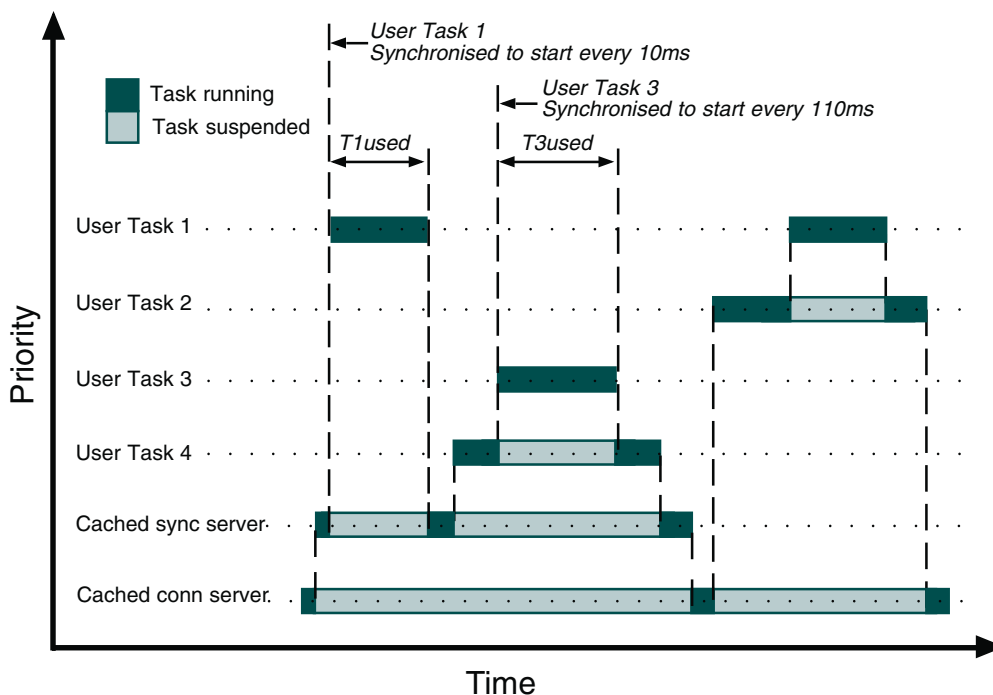

Figure 7.2.2a User task block server interactions

7.2.3 User task block servers (Cont.)

USER TASK BLOCK SERVER OPERATION

A higher priority user task block server always interrupts the running of a lower priority user task block server. Thus, whenever a given user task is running, all higher priority user tasks must have run to completion.

Figure 7.2.2b shows, schematically, the sequence of events that occurs during the running of a user task block server. These are as follows:

1. The user task is marked as 'busy'. During this 'busy' period lower priority tasks are suspended.
2. All connections sourced from higher priority tasks are copied into their destination blocks in this user task. This occurs as a single, indivisible, operation.
3. The blocks and their associated intra-task connections are then executed in order.
4. All connections sourced from this user task are now copied into their destination blocks in all higher priority user tasks, as a single, indivisible, operation.
5. The task 'busy' flag is removed.

Note This structure results in the least work being carried out by the highest priority task.

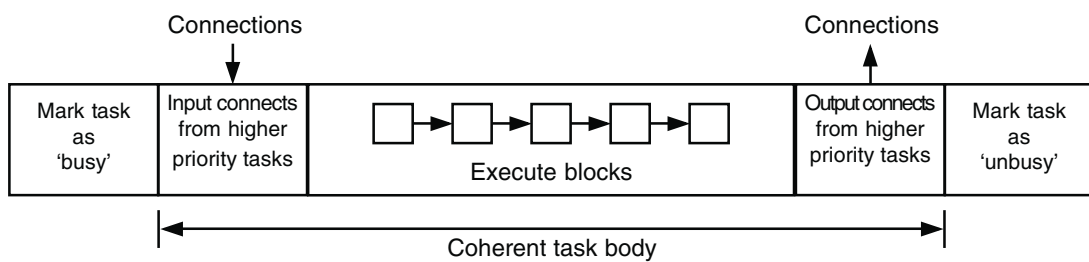

Figure 7.2.2b User task block server operation

7.3 USER TASK TUNING

7.3.1 Initiating repeat rates

At LIN Database startup, various checks are performed on the requested task repeat rates. Starting with the highest priority task, each block server initiates the following regulations,

- Firstly, ensuring any requested repeat rate is NOT faster than any higher priority block server task. Any lower priority block server task configured with a higher repeat rate is adjusted to match the next highest priority task.
- Then, ensuring that the requested repeat rate of the I/O synchronised block servers (User Task 1 and User Task 3 only), is an integer multiple of the I/O repeat rate value.

7.3.2 Automatic dynamic tuning

To compensate for the variable nature of user task execution times, the spread of CPU loading across user tasks and system tasks is monitored and user task repeat rates are altered, dynamically, to ensure a fair spread of CPU allocation.

The USERTASK block allows execution times and repeat times for all the user tasks and the cached block server to be monitored. The TACTTUNE block shows the percentage CPU usage by the various user and system tasks in the instrument. The prioritised nature of the user tasks should be allowed for when adjusting repeat rates (1 is the highest priority, 4 the lowest). The reported execution time for a user task may include a period of suspension whilst higher priority tasks execute.

Rapidly fluctuating repeat times for the lower priority tasks or a higher or unstable value of Stretch usually indicates an attempt to allocate too much total CPU time to the user tasks.

7.3.3 Manual tuning

The Stretch value in the USERTASK block indicates how much the dynamic tuning has had to slow the LIN Database. During normal operation the Stretch value should show a value of '1', indicating that the User Tasks are running at the requested rate, as configured in the Task Period field. Any small increases in the Stretch value, or occasional fluctuations caused by the abnormal loading of the User Tasks are acceptable. However, if the Stretch value increases significantly or is fluctuating erratically, the requested repeat rate will not be attained, causing the dynamic tuning to be inadequate. Examination of the USERTASK and TACTTUNE blocks will allow the identification of the CPU with the highest usage. Simply adjust the requested repeat rate to reduce the CPU load.

Note Some aspects of LIN Database execution can dynamically change the CPU usage, e.g. enabling an ACTION block or starting a Sequential Function Chart (SFC). These do not run continuously but affect the CPU loading when starting and while running.

7.4 DATA COHERENCE

7.4.1 Data flow between tasks

Data coherence is an important aspect of control strategies involving more than one user task. Data flow is defined as being coherent if during any single execution of a task the data input into it from outside the task is a 'snapshot' - unchanging during the execution of the task - and represents the values output from other tasks that have completed their execution.

Data coherence, by definition, refers to connections that are 'remote' (i.e. linking different tasks). Connections that are limited to within a task (i.e. 'local'), are simply dealt with by being copied from source to destination immediately before executing the destination function block.

For any task, there are three important types of remote connection. These types, and the way in which data coherence is ensured, are as follows.

CONNECTIONS INTO TASKS (FROM OTHER TASKS IN THE SAME INSTRUMENT (NODE))

In order to ensure that multiple uses (in this task) of the same value (from another task) always use the same iteration of the value, such values are copied prior to the execution of all the executable blocks of this task - i.e. a 'snapshot' is taken of all values external to this task.

Two types of connection apply - those from higher priority tasks to lower priority tasks, and those from lower priority tasks to higher priority tasks:

- Higher to lower priority. For coherence, whenever connections out of a task are used, all their values must result from the same iteration of that task. Owing to the priority structuring of the tasks, any connections from a higher priority task into a lower priority task meet this requirement. This is because a lower priority task cannot interrupt a higher priority task, which therefore always runs to completion. Hence, these connections are dealt with by a 'snapshot' copying at the start of the lower priority task.
- Lower to higher priority. A low priority task may be interrupted by a higher priority task before completion, and so be 'caught' with an incoherent set of output values. To avoid such invalid values being passed on, the last action of task execution is for the lower priority task to copy its set of coherent connections as a 'snapshot' to the higher priority task. In this way, the values passed on are always the last set of coherent values from a complete task execution.

CONNECTIONS INTO THIS TASK (FROM OTHER TASKS IN ANOTHER INSTRUMENT)

Connections between nodes are effected by the use of cached blocks. The process of cached block transmission, and reception at the destination end, is coherent for all the data within that function block.

At the destination end, the cached block exists on a cached block server. Connections from this cached block to other blocks effectively become inter-server connections within the same node, the coherence of which is guaranteed (as described in 'Connections into tasks...', immediately above).

7.4.1 DATAFLOW BETWEEN TASKS (Cont.)

CONNECTIONS OUT OF THIS TASK TO ANOTHER NODE

This type of connection results in data flow that is not coherent, because the data is transmitted across the network as individual field writes, rather than complete block updates. If coherence is required, the block(s) can be cached in the opposite direction, via an AN_CONN block for example. This is illustrated in Figure 7.4, where block A coherently connects to block B across the LIN via the AN_CONN block (bold lines), but the connection is non-coherent when routed via cached block B.

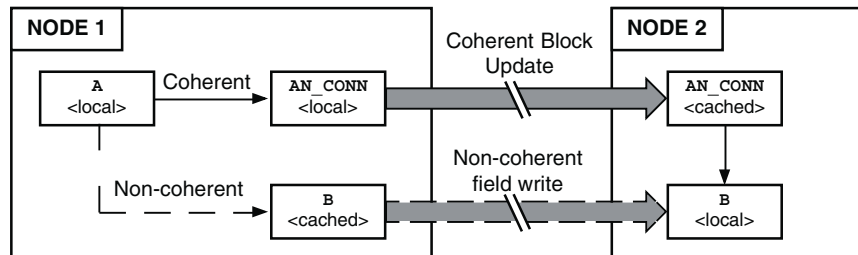

Figure 7.4 Coherent and non-coherent data flow across network

CHAPTER 8 EVENT LOG

This section describes the Event Log facility supported by this instrument.

The purpose of the Event Log is to record and store individually time stamped, Real-Time Clock, RTC, and instrument internal time, events generated in the instrument, and provide a means of indicating the impact of an event on the system.

Note This file is used to assist with diagnosing problems in the system.

8.1 THE EVENT LOG

Each event record is stored in a ASCII text file, using a single line for each event record. An I/O Subsystem with provision for two Processors use two Event Log files, 'event_l.udz' and 'event_r.udz' for left and right processors respectively. The 'event_l.udz' file is also used in Simplex I/O Subsystem. Eventually, as more event records are automatically added, the oldest event records are removed from the file. The file indicates the impact of the event on the system using the '!' character. Status, Warning, Error, and Major Error, are represented by 0, 1, 2 or 3 '!' characters respectively.

The following example shows a typical file resulting from the power-up and start-up of a database on the primary module of a duplex pair containing two GateWay instances.

Event Impact level	Real-Time Clock time stamp	Instrument Internal time stamp	Event Record Message
	08/01/00 01:42:11	(0x0000028A)	Power On / Reset
	08/01/00 01:42:11	(0x000002DC)	PRMT initial mode PRIMARY
	08/01/00 01:42:34	(0x000014B8)	Attempting Hot Start
!	08/01/00 01:42:34	(0x00001528)	GW System failed to Hot Start
	08/01/00 01:42:34	(0x00001528)	GW System started from GWF file
	08/01/00 01:42:34	(0x00001528)	GW Load from file = TMC.GWF
	08/01/00 01:42:34	(0x0000152C)	GW Load from file = TMCM.GWF
	08/01/00 01:42:35	(0x0000153C)	Database Started
	08/01/00 01:42:35	(0x00001543)	GW Start GWCON block = gwcon1
	08/01/00 01:42:35	(0x00001547)	GW Start GWCON block = gwcon2
	08/01/00 01:42:35	(0x0000156D)	PRMT block servers to PRIMARY
	08/01/00 01:42:35	(0x00001579)	Changeover state machine complete
	08/01/00 01:43:52	(0x00005166)	Locally generated Sync Request
	08/01/00 01:43:57	(0x000055F9)	Sync Completed Successfully
!!	08/01/00 01:44:22	(0x0000695D)	Secondary has inferior LIN status
	08/01/00 01:44:22	(0x0000695D)	Locally generated Desync Request
	08/01/00 01:44:22	(0x0000695D)	Desync Completed Successfully
	08/01/00 01:44:42	(0x000078FD)	GW Reload GWCON block = gwcon2
	08/01/00 01:44:42	(0x0000790B)	GW Stop GWCON block = gwcon2
	08/01/00 01:44:42	(0x00007910)	GW Load from file = TMCM.GWF
	08/01/00 01:44:42	(0x00007915)	GW Start GWCON block = gwcon2

Note The failure to Hot Start event record is a 'Warning', but Desync event record due to the disconnected LIN cable is an 'Error'.

Figure 8.1 Typical EventLog file, .udz, - example

8.1 The Event Log (Cont.)

The Event Log file, supports the recording of the following events,

■ Status

Status records, no ‘!’ characters, indicate normal operation events, e.g. power up, database start (hot start, cold start Hot/Cold start, Terminal Configurator, Network), database stop, Online Reconfiguration operations, normal synchronisation of a duplex pair, etc.

■ Warning

Warning records, one ‘!’ character, indicate minor abnormalities, e.g. hot start fails due to power off time exceeded, controlled changeover of a duplex pair, etc.

■ Error

Error records, two ‘!’ characters, indicate real faults on the system, e.g. automated changeover of a duplex pair due to a detected fault, running serial communications on unsupported versions of this instrument causing corruption of communications bus on power-up. If any Error is written to the Event Log file, the *Alarms.EventLog* and *Status.EventLog* fields of the database Tactician header block are setTRUE. This offers an output that can be linked a display to provide immediate identification of a problem that can have an effect on the system.

■ Major Error

Major Error records, three ‘!’ characters, indicate real faults in the execution of the instrument that must be investigated before continuing. If any Major Error is written to the Event Log file, the *Alarms.EventLog* and *Status.EventLog* fields of the database header block are setTRUE. This offers an output that can be linked a display to provide immediate identification of a problem that can have a serious effect on the system.

CHAPTER 9 DATA MANAGEMENT

This section describes the Data Management functionality supported by this instrument. Data Management functionality will only operate on hardware status level 4 or later, e.g. Hardware J4, Software Version 4, and a valid Licence, D10 to D90.

IMPORTANT *Hardware status level 4 and later contains flash memory that supports Data Management, but this will only be functional if the relevant licence is present. Use the Tactician Licence Tool to request a licence upgrade.*

The purpose of Data Management is to record, archive and visualise data values derived from a strategy during run-time. The data values are recorded to a file stored in the flash memory of the instrument, and can then be archived to a maximum of three FTP (File Transfer Protocol) Servers.

The main topics covered are as follows:

- Data Recording ([section 9.1](#))
- Data Archiving ([section 9.2](#))
- Data Management Configuration ([section 9.3](#))

Note Refer to the T2550 PAC Tutorial/User Guide, Part no. HA 029 723, for full details about Data Management configuration.

9.1 DATA RECORDING

Data recording is the process of writing data values derived from selected parameters in the instrument strategy to a Data Recording file, .uhh, see [Data Recording File, .uhh](#). To simplify the organisation of the recorded fields, they are configured in to groups, see [Data Recording Groups](#), and held in the internal flash memory of the instrument. The instrument can be configured to automatically push the .uhh files via the network to a defined FTP Server for archiving, see [Data Archiving](#).

Data recording is configured using LINtools, see *LINtools help file (Part no. RM 263 001 U055)*, and downloaded to the instrument with the database file, .dbf.

Note Instrument flash memory problems can be resolved by inspecting the RMEMDIAG block, see LIN Block Reference Manual, Part no. HA 082 375 U003.

9.1.1 Data Recording File, .uhh

The Data Recording file, .uhh, is an electronic tamper-resistant file that is used to record the values derived from the instrument during run-time. It is a non human-readable file format, that can only be interpreted by **Review** software.

9.1.2 Data Recording Groups

A Data Recording Group is a set of LIN block fields that are recorded to one sequence of files providing a method of organising recorded data, e.g. a single group can be created for each area of the plant/system. This provides the ability to group fields to best suit the process requirements. Each field is assigned to a group, identified by an RGROUP block. Each group records the configured field value at a specified rate. Fields may be assigned to multiple groups simultaneously, allowing the defined field to be recorded at different rates.

It is possible to record up to eight groups simultaneously, i.e. one RGROUP block per recording group, with a maximum of 127 data values per group.

9.2 DATA ARCHIVING

Data archiving applies to the process of copying recorded data from the instruments' internal flash memory to .uhh files on a defined FTP Server across a network via FTP, see [File Transfer Protocol \(FTP\)](#). The archived .uhh file can then be replayed using an off-line tool, **Review** software.

A maximum of three FTP servers can be defined in the **Instrument Options** page in the **Instrument Properties** dialog to provide a back-up service for archiving the .uhh files. When multiple FTP Servers are configured the .uhh files are archived to all defined FTP Servers.

Note Archiving problems can be resolved by inspecting the RARCDIAG block, see [LIN Block Reference Manual, Part no. HA 082 375 U003](#).

9.2.1 File Transfer Protocol (FTP)

File Transfer Protocol (FTP) is a commonly used Server/Client transfer mechanism. It allows the instrument to act as a FTP client to up to three FTP Servers for the purpose of transferring recorded files from the flash memory to a remote computer.

9.3 DATA MANAGEMENT CONFIGURATION

Data Management is configured using LINTools. Groups of recorded fields are defined in the instrument database, and can be individually customised using the Data Recording Configurator. Configuring individual fields provides a clear identification of each recorded field when displayed in **Review**. LINTools also provides the facility to define the FTP Servers used to archive the .uhh files, via the **Instrument Properties** dialog. Once the files are archived to the defined FTP Servers, **Review** can be configured to display .uhh files from the different groups and instruments.

To configure data management,

- 1 Define the data recording configuration using LINTools.
- 2 Define the data archiving configuration using the Instrument Properties in LINTools.
- 3 Define the data visualisation configuration using Review.

*Note Review can pull files directly from the instrument. It is not recommended but can be configured using the **Auto-Backup + Transfer** dialog in Review, and requires a **User Name**, 'history', and a **Password**, 'history'.*

- 4 Configure the FTP Servers.

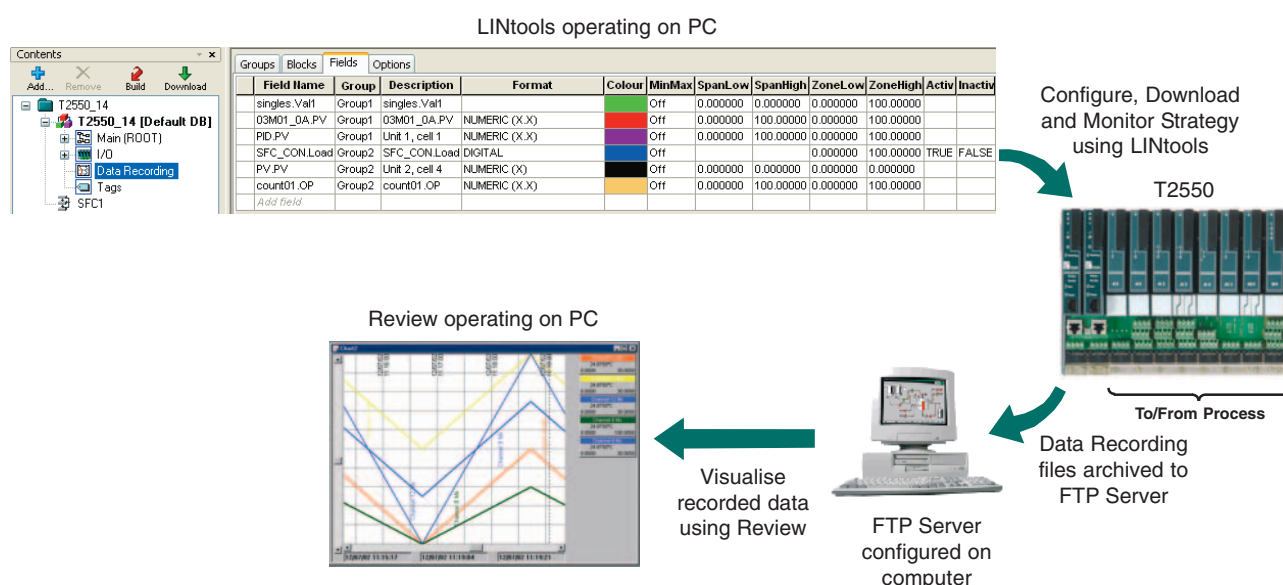

Figure 9.3 Data Management Configuration

CHAPTER 10 ERROR CONDITIONS AND DIAGNOSTICS

This chapter describes the various ways to tell if a fault has occurred in the T2550 instrument, (not in the process being supervised).

The main topics covered are:

- Error indication types ([section 10.1](#))
- LED error displays ([section 10.2](#))
- Power-up failures ([section 10.3](#))
- Power On Self Tests (POSTs) ([section 10.4](#))
- Diagnostic blocks ([section 10.5](#))

10.1 ERROR INDICATION TYPES

Error indications include:

- LEDs. The LEDs are the most immediate source of error and instrument status information concerning Basic I/O System (BIOS) start, watchdog functions and normal running. During BIOS start, the LEDs are momentarily illuminated to indicate the BIOS status. If a T2550 IOC Module start fails, the pattern that these LEDs adopt prior to the failure is helpful to service engineers, so it is recommended that this pattern is recorded (along with the unit serial number) before a service call is made.
- POSTs. The results of Power On Self Tests (POSTs) can be used to pinpoint error conditions in the instrument. Refer to *Power On Self Tests (POSTs) And Error Numbers section*.
- Diagnostic blocks. A range of function blocks can be included in the running Strategy Database to provide diagnostic information on various topics, including the redundancy mechanism, the ICM (Inter-processor Communications Mechanism), the I/O interface, and others.

10.2 LED ERROR DISPLAYS

The LEDs are the primary method of displaying errors.

10.2.1 LEDs

Figure 10.2.1 shows the T2550 IOC Module front panel LEDs. Table 10.2.1 specifies their functions.

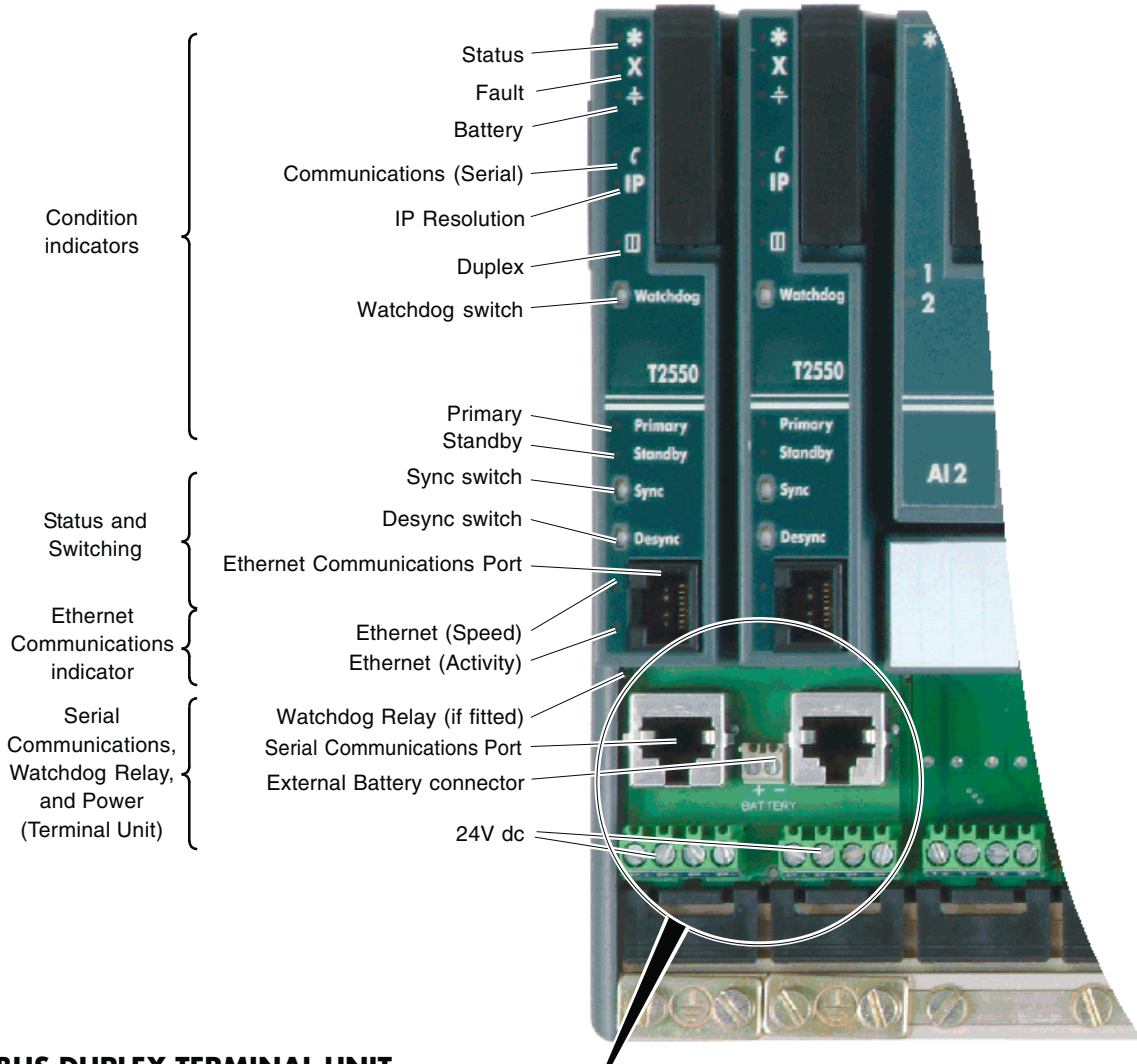

PROFIBUS DUPLEX TERMINAL UNIT

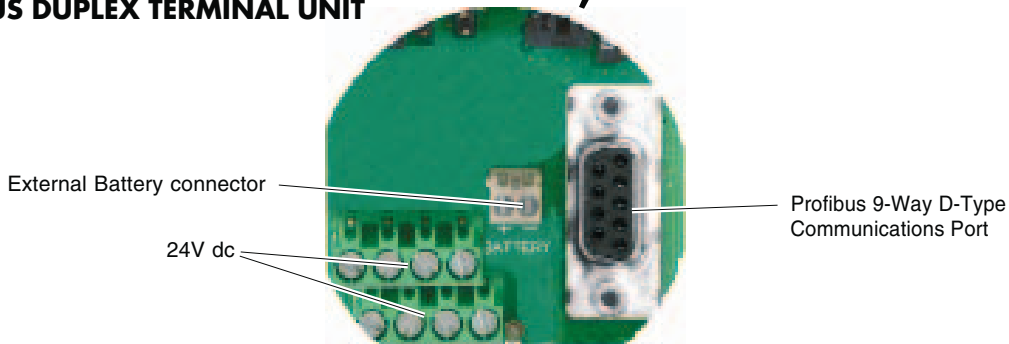

Note The Simplex Unit does not support the external battery supply, but does support battery backup via an internal battery mounted on the Simplex Terminal Unit.

Figure 10.2.1 Front panel layout (Redundant Configuration)

10.2.1 LEDs (Cont.)

LED	Colour	Function
Status	Green	Main Power input valid
	Off	Main Power input failed
Fault	Red	Module missing/faulty, incorrect type/base, any H/W fault, Watchdog Failure if ALL other LED's are extinguished, including Status LED
	Flashing	Database file unsaved, missing, or faulty. A '*.dbf' and corresponding '*.run' file do not exist on the T2550
	Off	No H/W faults detected
Battery	Green	Battery OK
	Flashing	Battery failed or not fitted
	Off	Battery deliberately not fitted
Communications	Yellow	T2550R module transmitting field communications
	Off	T2550R module not transmitting field communications
IP Resolution	Yellow	IP address resolved successfully
	Flashing	IP address being resolved or the cable is broken/disconnected
	Off	IP address cannot be resolved or DHCP failure
Duplex	Green	Primary and Secondary T2550R modules are coupled
	Flashing	Primary and Secondary T2550R modules are decoupled
	Off	Not operating in Redundant mode
Primary	Green	This is the Primary T2550R module and a running strategy
	Flashing	The Primary T2550R module is loading a strategy or idle
	Off	Not Primary T2550R module
Standby	Yellow	This is the Secondary T2550R module and is synchronised
	Flashing	The T2550R modules are synchronising
	Off	Not the active Secondary T2550R module
Ethernet (Speed)	Green	100 MB Ethernet (speed) configuration
	Off	10 MB Ethernet (speed) configuration
Ethernet (Activity)	Yellow	Connected to live Ethernet network
	Sporadic Flashing	Ethernet network traffic detected
	Off	Ethernet connection invalid
<i>Notes</i>		
1 All LED's flash at a rate of 600ms ON, 600ms OFF.		
2 If ALL LED's are extinguished, excluding the Fault LED, the instrument has Watchdogged. If the Options Switch SW2:S1 is set OFF, press the Watchdog switch to reset the instrument. This has no effect when a T2550R is not in a watchdog condition.		

Table 10.2.1 LED functions

10.2.2 Instrument failure modes

The LEDs directly indicate the following T2550 IOC Module failure or potential failure modes:

- Loss of Power
- Watchdog
- Communications failure
- Loss of primary status
- Decoupling
- Desynchronisation

When either or both T2550R modules, running as one of a redundant pair, fail, it usually changes its redundancy state in response to the failure, e.g. from primary to secondary, or from synchronised to unsynchronised and sometimes, coupled to decoupled.

LEDs are illuminated to assist with identifying the state each T2550R module is in, as well as the nature of any failure. (The 'Standby', 'Communications' and/or 'Duplex' LEDs will be on, off or flashing as indicated in [Table 10.2.1.](#))

10.2.3 Power failure

In the event of a power failure, the affected T2550 IOC Module enter a 'Power fail' state. This occurs when the 24V supply cannot power the T2550 instrument.

In the event of a 24V power failure the 'Status' LED on the T2550 IOC Module will be extinguished. If an external battery is fitted power will remain to allow Hot Start operation, but the cause must be located and repaired within the life span of the battery. An internal supercap will support the Hot Start facility for up to 24 hours.

10.2.4 Watchdog failure

In the event of a Watchdog failure, the affected T2550R Module enters a 'Watchdog fail' state.

If the Watchdog Retry switch (Duplex Unit - SW2:S1) is set ON, the T2550R module will automatically attempt to restart the CPU. If the Watchdog Retry switch is set OFF, ALL LEDs are extinguished excluding the 'Fault' LED, and the CPU will only restart after operating the 'Watchdog' switch on the T2550R module.

On watchdog failure in redundant mode, the surviving T2550R module adopts (or maintains) the PRIMARY UNSYNCHRONISED state. The database can only run if synchronised before changeover, halting it otherwise.

10.2.5 Inter-processor Communications Mechanism for redundancy failure

Note An Inter-processor Communications Mechanism (ICM) failure is not associated with any single T2550 IOC Module, and so is not classed as either primary or secondary fault.

An Inter-processor Communications Mechanism (ICM) failure occurs when the primary and secondary T2550R modules can no longer communicate with each other across the internal high-speed link, making database synchronisation impossible to maintain. An ICM failure causes the primary and secondary modules to decouple, but does not permit a changeover.

ACTION IN THE EVENT OF ICM FAILURE

In the event of an ICM failure the T2550 IOC Module will decouple. Decoupling is indicated by the flashing 'Duplex' LED on the modules, see **Decoupled Instrument section**. The strategy must be designed to send the supervisory system an appropriate alarm to annunciate this ICM failure state, (e.g. use the 'RED_CTRL' block's 'PrHWstat.ICM_Ok' and 'SeHWstat.ICM_Ok' bits).

If the ICM does fail, eliminate the cause of the failure, by first replacing the secondary T2550R module. If this solves the problem re-synchronise the T2550R modules. If the fault persists, the running, primary T2550R module is the most likely cause and should be replaced. Initially the original secondary should be re-fitted within 12 hours as it is unlikely to be faulty. The faulty primary T2550R module, should now be removed, causing the secondary to take over as sole primary but with a stopped database. If appropriate, restart the existing database by powering down and then up again. Otherwise, reload a 'default' database and restart it in the new primary T2550R module.

This last option is a Cold Start and requires manual supervision of the plant during the transition.

Note A fault in the Terminal Unit is a possible but unlikely cause of ICM failure.

10.2.6 LIN failure

This occurs when a T2550 IOC Module is not communicating over the LIN, because the cable is damaged or disconnected or there is a hardware (electronics) failure.

An interconnection failure causes the relevant 'Ethernet (Activity)' LED associated with the affected T2550 IOC Module to extinguish and the yellow 'IP' LED to flash.

A LIN failure in a synchronised primary T2550R Module causes primary/secondary changeover and loss of synchronisation, i.e. Primary synchronised adopts Secondary unsynchronised, and Secondary synchronised adopts Primary unsynchronised.

If an unsynchronised primary T2550R module suffers a LIN failure no changes of state occur.

In the event of a LIN failure in a synchronised secondary T2550R module, it adopts the Secondary unsynchronised state ('Standby' LED off), and the primary T2550R module correspondingly desynchronises to the Primary unsynchronised state. If the secondary was unsynchronised at the time of the failure, no change of state occurs.

EFFECT OF LIN FAILURE ON REDUNDANCY MODE CONTROL

LIN failure affects the ability to synchronise Primary and Secondary T2550R modules, for example, a LIN-failed secondary T2550R module cannot successfully be synchronised with the primary by pressing the primary's 'Sync' switch. Attempts to do this are inhibited by the redundancy control software, and is indicated by the yellow 'Standby' LED's lack of response.

10.2.7 Decoupled Instruments

This occurs when communications between unsynchronised primary and secondary modules are aborted because of a conflict regarding the unsynchronised state. This causes the two T2550R modules to become decoupled. There are various reasons for this decoupling, but generally it is due to a serious error, causing the modules to assume they should be more than unsynchronised.

A decoupled state is indicated by the flashing ‘Duplex’ LEDs on both T2550R modules. It can occur on a dual power up if the two T2550R modules wildly conflict in their outlook of how they both powered down, i.e., if the two modules power down, both as synchronised secondary modules, when powered up together, they may decouple - because the dual power up cannot resolve the differences between them.

<u>Primary</u>		
‘Duplex’ LED	Flashing green	Decoupled Instrument
<u>Secondary</u>		
‘Duplex’ LED	Flashing green	Decoupled Instrument

ACTION IN THE EVENT OF DECOUPLED INSTRUMENTS

In the event of the primary and secondary modules becoming decoupled, the T2550R modules are already unsynchronised, so rectify this by pressing the ‘Sync’ switch on the primary module. The strategy must be designed to send the supervisory system an appropriate alarm to annunciate this state, (e.g. use the ‘RED_CTRL’ block’s ‘PrSWstat.Decoupld’ and ‘SeSWstat.Decoupld’ bits).

Caution

The decoupled T2550R modules may not always re-synchronise after using the ‘Sync’ switch, so further investigation MUST ensure the cause is located and eliminated. If successful, both ‘Duplex’ LEDs illuminate steady.

10.2.8 Desynchronisation

Desynchronisation is generally caused when the Database is stopped. If the database in the primary T2550R module stops running, the green ‘Primary’ LED flashes and the two T2550R modules desynchronise. No changeover occurs and attempts to resynchronise are inhibited by the redundancy control software until the primary T2550R module starts running again.

Only when the decision to changeover has been accepted, see Start-up Routine section, can the secondary (example, right-hand) T2550R module assume control. Before the changeover can occur, the yellow ‘Standby’ LED of the secondary module is extinguished, and the green ‘Primary’ LED starts to flash while loading the strategy from the primary (example, left-hand) T2550R module. When the strategy has finished loading the previously secondary (example, right-hand) T2550R module assumes control indicated by the continuously illuminated green ‘Primary’ LED. The changeover is completed when the database on the previously primary (example, left-hand) T2550R module is stopped.

10.3 POWER-UP FAILURE

10.3.1 Power-up routine

A number of error conditions can occur during the power-up phase. This power-up routine is described earlier, and should be referred-to for detailed information. Various messages are generated by the T2550 IOC Module during power-up. These messages can be displayed by running a ‘Telnet’ session on a Computer via the ELIN network.

Figure 10.3.1a charts the power-up routine in a simplified schematic form, and Figure 10.3.1b shows the hot start ‘subroutine’ that may be called by the main power-up routine. The two flow diagrams also show various error conditions.

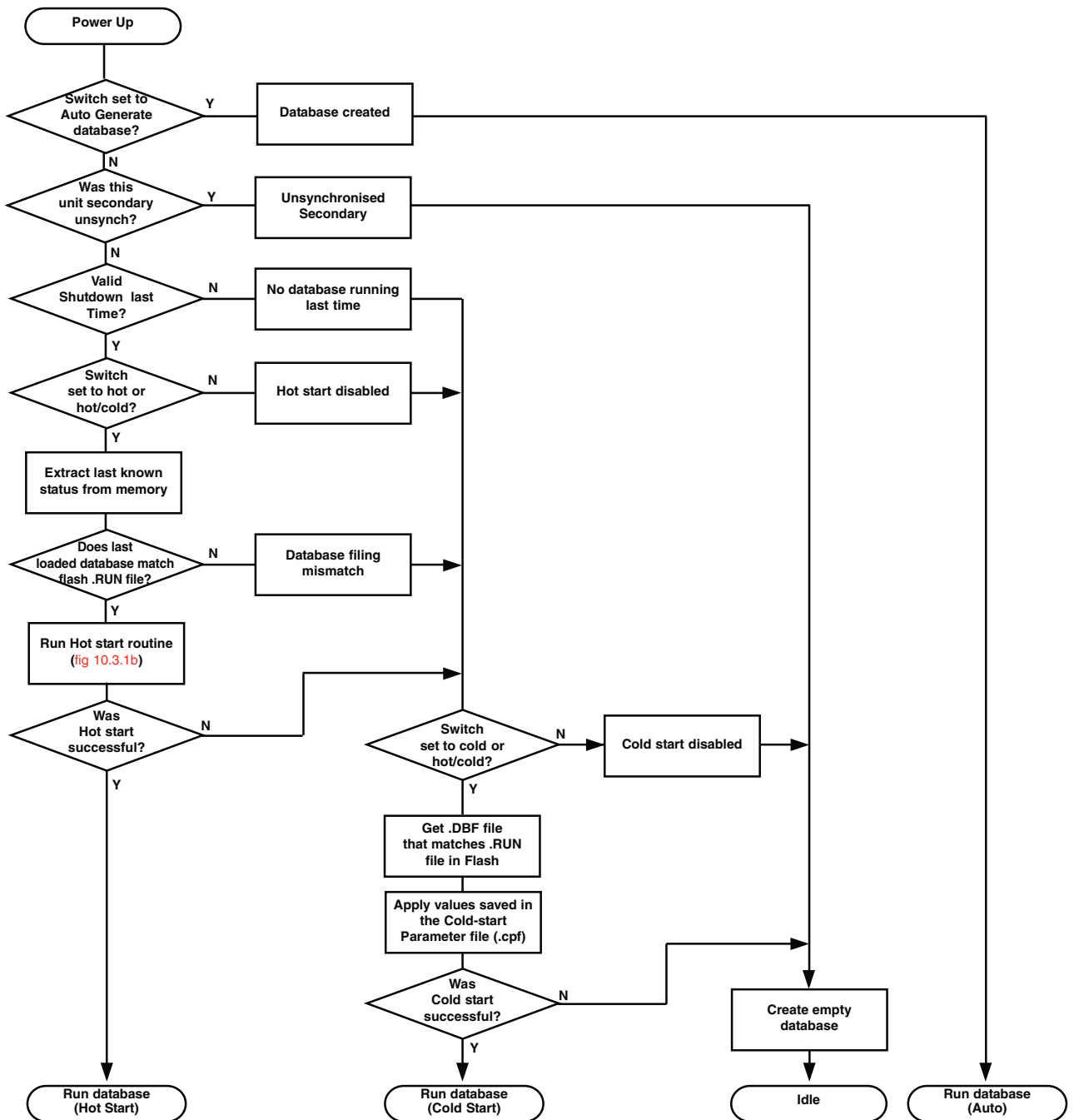

Figure 10.3.1a Power-up routine flowchart - simplified

10.3.1 POWER-UP ROUTINE (Cont.)

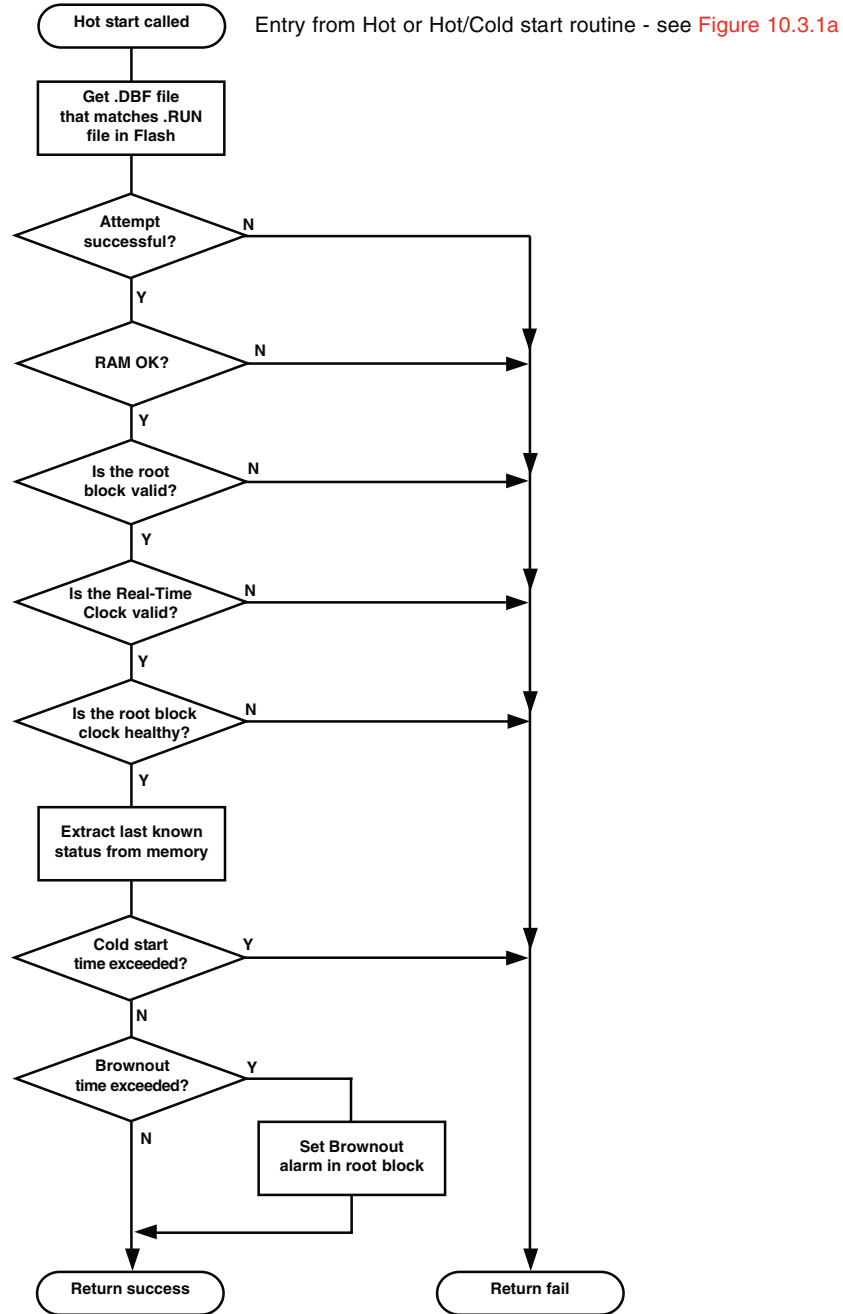

Figure 10.3.1b Hot/Cold Start routine flowchart - simplified

10.4 POWER ON SELF TESTS (POSTS)

Whenever a T2550 instrument is powered-up, it automatically performs the Power On Self Tests (POSTs). These are a series of diagnostic tests used to assess the installed instrument.

At switch on, the Basic I/O system (BIOS) starts running and checks that the Central Processor Unit (CPU)* is operating correctly. This stage of power-up is apparent by the lighting of all 'LEDs' shown in [Figure 10.2.1](#).

*Note * This CPU is a part of the internal electronics of the T2550 IOC Module.*

The start-up process initiates the Power On Self Tests (POSTs) with the loading of the application and system code from the Compact Flash card (accessible at the rear of the T2550 IOC Module). Firstly the Boot ROM is checked, running each POST to ensure the Compact Flash Card (accessible at the rear of the T2550 IOC Module) is functioning correctly, then the T2550 IOC Module is checked, again running each POST to ensure the application is operating correctly. Each POST is initiated, however this may not always be in the same sequence.

Should any POST fail, the LEDs display a pattern that may be of use to service engineers, but these are not fully interpretable by the user. The pattern is displayed for approximately 10 seconds before the instrument enters a watchdog state. However, the location of the POST failure is indicated by the 'Standby' LED, if illuminated, an Application POST has failed, whereas if it remains extinguished a Boot ROM POST has failed.

Note For full list of Power On Self Tests refer to the Power On Self Tests (POSTs) And Error Numbers section.

The T2550 instrument now attempts to start the software, determining first whether the Options switch (SW1:S1) on the Terminal Unit is set for redundant or non-redundant operation.

If redundant working is required, the primary/secondary status of each T2550R module is decided according to a specific criteria, see *Start-up routine* section, if necessary, using 'signature' data relating to last-time's power down, automatic synchronise states and so on.

A check is made to ensure that the ICM communications are valid, and if so, the primary T2550R module continues its power up sequence, according to the mode selected. If synchronisation is permitted the 'Standby' LED starts flashing on and off when the primary T2550R module starts to download data to the secondary T2550R module .

If the ICM test fails, or if non-redundant working is required, the T2550R module continues the power up sequence, according to the mode selected.

10.5 DIAGNOSTIC BLOCKS

Several diagnostic function blocks are available from the DIAG category, that can be installed in the LIN Database at configuration time to help in diagnosing any error conditions that may arise in the running strategy. The LINtools program can then be used, via the LIN network, to look at the fields in these blocks to find out what is happening.

The table below shows a list of diagnostic blocks that are automatically generated as part of the automatically created LIN Database, when the **Options switches** are set correctly, see *Terminal Unit Switches* section.

Note All function blocks are described in the LIN Block Reference Manual (Part no. HA082375U003).

BLOCK	FUNCTION
DB_DIAG	Database diagnostics block. Shows actual and maximum resource levels of the database by the current software. Displayed parameter values are only valid at runtime.
EDB_DIAG	External database diagnostics block. Shows connection information to one external database running in remote instruments and monitors the cached block update rate tuning algorithm.
EIO_DIAG	Ethernet I/O system diagnostic block. Shows the current state (Healthy/Unhealthy) of the expected and actual I/O modules at each site. It can display a maximum of 16 I/O sites on one screen.
ELINDIAG	ELIN diagnostics block. Statistics on the operation of the Ethernet Local Instrument Network (ELIN).
ICM_DIAG	ICM diagnostics block. Statistics on numbers and types of message passing between redundant T2550R modules.
IDENTITY	IDENTITY diagnostics block. Identifies the instrument containing this block.
LIN_DEXT	LIN High-level diagnostics extension block. Statistics on the operation of the Local Instrument Network (LIN).
OPT_DIAG	Options/Licence Control System diagnostics block. This block shows the user system attributes that may impose some limit of operation, or cause a licence violation alarm. The block is not essential to the LIN Database, and can be added while on-line.
RED_CTRL	Redundancy Control block. If Duplex systems are configured, this block shows Processor Redundancy Management Task (PRMT) parameters. It can also be used to trigger processor module synchronisation, desynchronisation, and primary/secondary processor swap.
SFC_DIAG	Sequence diagnostics block. If SFC is enabled, this block shows actual and maximum resource levels of the sequence by the current software. It displays parameter values that are only valid at runtime.
TACTTUNE	Tactician tuning block. System task monitoring in priority order.
USERTASK	User Task diagnostic block. Strategy task performance monitoring.

Table 10.5 Typical diagnostic blocks required

CHAPTER 11 SERVICE

This section describes the regular preventive changing of back-up batteries etc., and shows how to replace the Compact Flash Memory card and live operating Modules.

The main topics covered are:

- Preventive Maintenance Schedule (section 11.1)
- Replacement Procedures (section 11.2), including Compact Flash Memory card, Live T2550R Module, and Battery Replacement (Simplex Only).

For details of how to update and change the instrument's system software, boot ROM and libraries, please contact the nearest manufacturer's service centre.

Caution

All circuit boards associated with this unit are susceptible to damage due to static electrical discharges of voltages as low as 60V. All relevant personnel must be aware of correct static handling procedures.

11.1 PREVENTIVE MAINTENANCE SCHEDULE

The following periods are recommended to guarantee maximum availability of the instrument, for use in what the manufacturer considers to be a normal environment. Should the environment be particularly dirty, or particularly clean, then the relevant parts of the schedule may be adjusted accordingly.

The following are recommended:

1. Every two to four years, the service consumables listed below should be replaced. The recommended replacement period is a function of the average ambient temperature in which the instrument operates. At an ambient of 50 degrees Celsius, the recommended replacement period is two years. For an ambient of 20 degrees Celsius the recommended period is four years.

Service consumables are:

- a) Battery (Simplex T2550S module only) - Part no. PA250983.

Whenever preventive maintenance is performed, it is recommended that a visual inspection of the instrument be made, and any deposits of dirt or dust removed using a low-pressure compressed 'air duster' such as are available from most electronics distributors.

11.2 REPLACEMENT PROCEDURES

11.2.1 Firmware upgrade

The manufacturer can supply replacement Compact Flash Memory cards pre-programmed with the latest firmware version. This allows the user to upgrade the T2550 IOC Module just by replacing the card. In such cases, the user is responsible for reloading configuration files in the T2550 IOC Module.

Alternatively, the manufacturer's agents can upgrade the firmware version with the card *in situ* thus retaining the user configuration.

COMPACT FLASH CARD REPLACEMENT PROCEDURE

Figure 11.2.1 shows the replacement of the 'Compact Flash card' fitted to current units. This procedure allows databases, user configurations, IP address and Network name, to be transferred from one module to another, allowing the 'Mean Time to Replace' to be reduced to a minimum.

Note The Node address is not transferred by replacing the Compact Flash Memory card.

1. Remove the relevant T2550 IOC Module from the Terminal Unit, see *Installation*.
2. At the rear of the T2550 IOC Module, lift the front edge of the card, and pull it out of its connector.
3. Fit the replacement card.
4. Re-assemble the T2550 IOC Module.

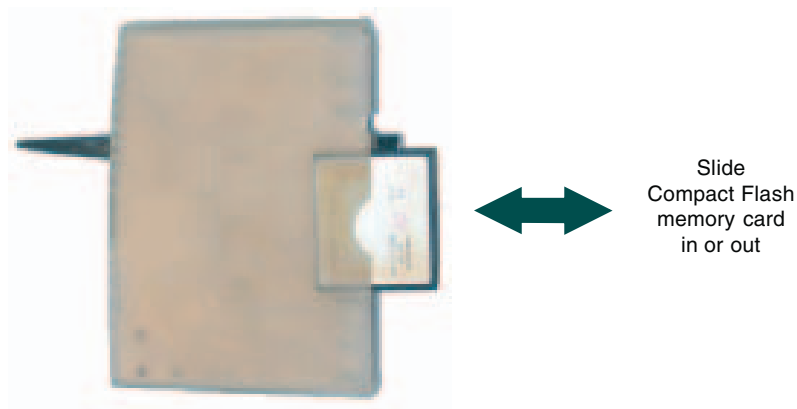

Figure 11.2.1 Replacing the Compact Flash Memory Card

11.2.2 Live T2550R Module replacement

Live replacement of a failed T2550 IOC Module can be carried out, without wiring disconnections. When operating in Redundant mode either T2550R module can independently drive the I/O modules allowing the replacement T2550R to load its strategy and current status from the current primary T2550R Module.

Note It is recommended that a backup of the strategy is made before replacing any T2550R module.

LIVE T2550R MODULE REPLACEMENT PROCEDURE

1. Ensure the T2550R Module to be replaced is NOT the current primary module.

Note Always ensure the module being replaced in a redundant system is operating as the secondary T2550R module. If the failed T2550R Module is the primary T2550R Module, press the 'Sync' switch to initiate the synchronisation process. This will ensure that both modules are synchronised allowing the primary and secondary T2550R module to changeover.

Operation of the primary T2550R modules 'Desync' switch may be required to desynchronise the T2550R modules and ensure the failed module is operating as the secondary. See User Interface section for details.

2. Shutdown the secondary T2550R module. To shutdown the secondary module, press and hold the 'Desync' switch for longer than 3 seconds.
3. When successfully shutdown, indicated when all LEDs are extinguished, the T2550R can be safely removed from the Terminal Unit.
4. Fit the replacement T2550R module, see Fit a Module section. When the module has automatically initialised, indicated by the secondary T2550R module LEDs, press the 'Sync' switch on the primary T2550R module to resynchronise both T2550R modules, which will permit redundancy changeover.

11.2.3 Battery replacement (Simplex only)

WARNING

The battery being replaced is likely to be partially charged, and must not be short-circuited, intentionally or inadvertently, as to do so carries a risk of explosion with possible emission of dangerous and corrosive materials.

BATTERY REPLACEMENT PROCEDURE

1. Remove the relevant T2550S module from the Simplex Terminal Unit, see *Installation*.
2. Carefully pull the battery from the socket.
3. Dispose of the battery according to local regulations regarding batteries.
4. Fit the new battery, in the appropriate position.
5. Re-assemble the unit.

Intentionally left blank

APPENDIX A SPECIFICATION AND COSHH

A.1 INSTALLATION CATEGORY AND POLLUTION DEGREE

This product has been designed to conform to BS EN61010 installation category II and pollution degree 2. These are defined as follows:

A.1.1 Installation category II

The rated impulse voltage for equipment on nominal 230V ac mains is 2500V.

A.1.2 Pollution degree 2

Normally, only non-conductive pollution occurs. Occasionally, however, a temporary conductivity caused by condensation shall be expected.

A.2 SPECIFICATION

This specification defines the T2550 instrument components:

- General, including the Base Unit ([section A.2.1](#))
- T2550 Terminal Unit ([section A.2.2](#))
- T2550 IOC Module Hardware ([section A.2.3](#))
- T2550 LIN IOC Module Software ([section A.2.4](#))
- T2550 Profibus IOC Module Software ([section A.2.5](#))

A.2.1 General specification

Physical

Dimensions

Base Unit:	162 mm wide x 180 mm high to 467 mm wide x 180 mm high depending on Base Unit option
Base Unit fixing centres:	Dependant on Base Unit option

Weight

Base Unit without modules:	0.6kg to 2.5kg max depending on Base Unit option
Base Unit with modules:	1.0kg to 3.0kg max depending on Base Unit option

Safety earth connections	By 2 M4 earth stud on lower flange of the Base Unit. Plus optional protective earth terminal strip
--------------------------	---

Environmental

Temperature	Storage:	-25 to +85°C
	Operation:	0 to + 50°C
Humidity	Storage/Operation:	5 to 95% RH (non-condensing)
RFI	EMC emissions:	BS EN61326 2002-02
	EMC immunity:	BS EN61326 2002-02
Safety Specification		BS EN61010-1/A2:1993
Vibration		To IEC1131-2 section 2.1.3
		(0.075mm peak amplitude 10 to 57 Hz; 1g 57 to 150 Hz)

A.2.2 T2550 Terminal Unit specification

Physical

Shows the physical properties of both LIN Terminal Units and Profibus Terminal Units.

Dimensions (approx.)

Duplex, LIN and Profibus:	50 mm wide x 110 mm high
Simplex:	25 mm wide x 110 mm high

Weight (approx.)

Duplex, LIN and Profibus:	0.1kg
Simplex:	0.1kg

General

Shows the physical properties of both LIN Terminal Units and Profibus Terminal Units.

Switches

Duplex - SW1, segment 1:	Redundant/Non-redundant mode select (duplex)
Duplex - SW1, segment 2 to 8:	Instrument Address
SW2, segment 1:	Watchdog retry (trip and try again mode)
SW2, segment 2 and 3:	Hot/Cold restart and Automatic Database Generation
Simplex - SW1, segment 1:	Not Used
Simplex - SW1, segment 2 to 8:	ELIN address (simplex)
Simplex - SW1, segment 9 to 10:	Hot/Cold restart and Automatic Database Generation

Links

LK1 and LK2:	Protocol selection. LK1 and LK2 must be fitted as stated
--------------	--

LIN Terminal Unit

Pins1-2	RS485 3-wire Modbus TCP/IP communications.
Pins2-3	RS485 5-wire Modbus TCP/IP communications.

Profibus Terminal Unit

Pins1-2	RS485 Profibus Network terminated.
Pins2-3	RS485 Profibus Network unterminated.

Power Requirements

Shows the physical properties of both LIN Terminal Units and Profibus Terminal Units.

Main supply:	24V dc nom. (18 to 36Vdc) at 50W per module, maximum. Two supplies 'OR'ed together to provide Redundant power supply on Duplex LIN or Profibus Terminal Unit. One supply on the LIN Simplex Terminal Unit.
Surge Current:	8A max.

Caution

If the supply voltage drops below 18V during start-up (as a result of current limiting for example) the instrument will fail to start. It will then attempt a re-start, causing the unit to enter a repeating cycle. Damage will be caused to the instrument if it is left in this state for more than 30 mins.

Backup supplies

External (option) (Duplex):	3Volt on Duplex LIN or Profibus Terminal Unit. Typical drain per processor = 300 μ A at <3.3V
Internal (Simplex):	LIN Simplex Terminal Unit ONLY, Lithium Manganese Dioxide battery. Maintains the Real-Time Clock for 1.5 years continuous use.

Other connections

Profibus Connection

Duplex, Profibus:	9-Way D-Type, supporting Profibus communications
-------------------	--

Note **Relay connections** available on an optional Terminal Unit. For each T2550R Module there is one Watchdog relay and two 'alarm' relays (operation configured by the user). For each relay, only the common and normally open contacts are used, these being short circuit under normal operating conditions, and open circuit under alarm or power-off conditions.

A.2.3 T2550 IOC Module hardware specification

General

Ethernet and Profibus Module

T2550R: 50mm wide x 90 mm high x 81mm deep - locked, 114 mm - unlocked

T2550S: 25mm wide x 90 mm high x 81mm deep - locked, 114 mm - unlocked

Flash memory

Removable flash memory: 32 MByte removable flash card

Hardware status: J4 and later (J1 and later for Profibus) 7 MByte Internal Flash memory used for Data Recording.

Note **The modules internal flash memory has a total of 8 MBytes, but 1 MByte is reserved for operation.**

Panel Indicators

Light emitting diodes (LEDs) for:

- Status (24V dc nom - Main supply)
- Fault indicator
- Battery
- Communications
- IP Resolution
- Duplex (redundant mode)
- Primary
- Standby
- Ethernet (speed)
- Ethernet (activity)

Control switches

Switches for:

- Watchdog Reset
- Synchronise/changeover
- Desynchronise

Ethernet Communications port(s)

Ethernet communications support

Connectors: One RJ45 connector per IOC Module.

Network medium: Ethernet Category 5 cables.

Protocols: LIN over Ethernet / IP (ELIN), Modbus-TCP RTU slave, FTP.

Speed: 10/100 Mbps

Network Topology: Star connection to a hub

Line length (max): 100 metres, extendable by repeater

Allocation of IP address: Manual, DHCP, Link-Local or BootP

Isolation: 50V dc; 30V ac.

Profibus Communications port

Profibus communications support

Connector: One 9-way D-Type connector per IOC Module.

Network medium: Standard Profibus cables.

Protocols: Profibus slave.

Isolation: 50V dc; 30V ac.

Note **Profibus IOC module only.**

Other connections

Watchdog Relay: Common and normally open contacts used

Note **For each T2550 module there is one Watchdog relay. For each relay, only the common and normally open contacts are used, these being short circuit under normal operating conditions, and open circuit under alarm or power-off conditions.**

A.2.4 T2550 LIN IOC Module software specification

LIN Block libraries (continuous database function block categories)

Batch:	Sequencing recipe/record and discrepancy checking
Communications:	Instrument Communication blocks. Specific blocks MUST be included in the database to permit communications
Conditioning:	Dynamic signal-processing and alarm collection
Configuration (Header):	Instrument identity (Header) blocks
Control:	Analogue control, simulation and communications
Convert:	Convert dissimilar database field types, particularly enumerated values
Diagnostic:	Diagnostics
I/O:	Analogue and digital input output manual override
Logic:	Boolean, latching, counting and comparison
Maths:	Mathematical functions and free-format expressions
Organise:	Organise system screens and grouping data for logging
Programmer:	Control, monitor and schedule programs generated by the SetPoint Programme Editor
Recorder:	Control and manage data recording
Selector:	Selection, switching, alarm and display page management
Timing:	Timing, sequencing, totalisation and events

Continuous database resources

Number of function blocks (maximum)	256
Number of templates (maximum)	50
Number of libraries (maximum)	28
Number of EDBs (maximum)	32
Number of FEATTs (maximum)	256
Number of TEATTs (maximum)	128
Number of Servers (maximum)	6
Number of connections	256
Control database size (maximum)	85 kByte

Notes

1. *Apart from database memory sizes, these figures are default maximums and are the recommended limits for typical situations. Subject to note 2, below, it is possible to exceed some of the above maxima, although if a database with more resources than the default maximum is loaded, then the maximum is set to the new value and there may then be insufficient memory to load the entire database or allow Online Reconfiguration. In such a case, the 'connections' disappear first. (FEATTs are not subject to this problem, since when a database is saved, there are not normally any FEATTs present, so the default maximum cannot be overridden.*
2. *If the EDB maximum is exceeded, some EDBs will malfunction. This is likely to affect the LIntools facility.*

A.2.4 T2550 LIN IOC Module software specification (Cont.)

LIN Block software license categories

Block Type	Category				Description
	Foundation	Standard	Control	Advanced	
Batch RECORD, DISCREP, SFC_DISP, SFC_MON SFC_CON		✓	✓		Batch control and management
Communications GW_CON, GW_TBL, GWPROFS_CON	✓				Communications control
Conditioning AN_ALARM, DIGALARM CHAR, UCHAR, FILECHAR FIITER, LEAD_LAG, LEADLAG, FLOWCOMP, INVERT, RANGE AGA8DATA, GASCONC, ZIRCONIA	✓	✓		✓	Signal processing control
Control AN_CONN, DG_CONN ANMS, DGMS, MAN_STAT, MODE, SETPOINT, PID_LINK, SIM 3_TERM, LOOP_PID, PID, TUNE_SET	✓	✓	✓		Loop control and management
Convert REALTIME			✓	✓	Conversion control and management
Diagnostic All blocks	✓				Fault control and management
I/O AI_UIO, AO_UIO, DI_UIO, DO_UIO, FI_UIO, MOD_UIO, TPO_UIO MOD_DI_UIO, MOD_DO_UIO CALIB_UIO	✓				I/O control and management
Logic AND4, OR4, XOR4, NOT COMPARE, COUNT LATCH, PULSE		✓			Logical calculation control
Maths ACT_2A23WT, ACT15A3W, ACTION, DIGACT, ACTUI818 ADD2, SUB2, MUL2, DIV2, EXPR		✓	✓		Mathematical calculation control
Organise AREA, GROUP	✓				Screen and Data management
Programmer SPP_RAMP		✓			Setpoint control and management
Recorder DR_ANCHP, DR_DGCHP RGROUP	✓	✓			Data recording control and management
Selector ALC 2OF3VOTE, SELECT, SWITCH	✓	✓			Signal selection control and management
Timing DELAY, DTIME, RATE_ALM, RATE_LMT, SEGE, TOT_CON, TOTAL, TOTAL2 SEQ, TIMER, TIMEDATE, TPO	✓	✓			Time control and management
Control Module VLV1IN, VLV2IN, VLV3WAY, MTR3IN, DUTYSTBY, AN_ALM_2	✓				Hardware represented block

A.2.4 T2550 LIN IOC Module software specification (Cont.)

Sequence Control Resources

Sequence memory

Program data:	59 kBytes
SFC Resources:	53 kBytes
N° of independent sequence tasks:	68 simultaneously active
SFC Roots:	15
Steps:	212
Action associations:	848
Actions:	424
Transitions:	318

Modbus

Modbus communications support

Configuration Tools:	The Serial parameters of the instrument must be configured using the Computer based Modbus Tools software. The instrument parameters can be configured using the Computer based Instrument Properties dialog
Memory Size:	14 kBytes
Maximum Tables:	80 Diagnostics Registers = 16 general purpose registers + 1 register for each table
Operating Mode:	Master, Slave
Transparent Modbus Access (TMA/TalkThru):	Via Modbus Gateway file
Format:	Direct 32 bit, Reverse 32 bit (D, and S)
Tick Rate:	5ms
Number of facilities:	3 Modbus Gateway facilities
Redundancy:	Full control
Interface:	2 (Serial (COM1/COM2) + TCP/IP (TCP)). Serial interfaces are electrically limited to communicate with a maximum of 64 slave devices, 1 per register in the .gwf. TCP can communicate with 16 slave devices and 16 additional master devices, via the ENET3 and ENET4 ports.

Profibus

Profibus communications support:

Configuration Tools:	The Profibus parameters of the instrument must be configured using the Computer based Modbus Tools software. The instrument parameters can be configured using the Computer based Instrument Properties dialog
----------------------	--

Note To support communications via a Profibus Network, the dedicated Profibus hardware, Terminal Unit and IOC Module, MUST be used and specific Modbus Address registers MUST be configured appropriately, see Configuration.

Memory Size:	14 kBytes
Maximum Tables:	80 Diagnostics Registers = 16 general purpose registers + 1 register for each table
Operating Mode:	Slave
Baud Rate:	Determined by Profibus Master device, 12000000 max.
Format:	Cyclic and Acyclic, Input data and Output data
Tick Rate:	5ms
Redundancy:	Full control
Interface:	1 (Serial (9-Way D-Type)). The Serial interface can communicate with a maximum of 126 devices including a single Profibus Master device.

A.3 COSHH - BATTERY SPECIFICATION

Lithium Manganese Dioxide batteries are only fitted to the Simplex Terminal Unit.

Product: Back-up Batteries			
Part Number: PA250983 (mounted on circuit board assembly)			
HAZARDOUS INGREDIENTS			
Name	% Range	TLV	Toxicological Data
Manganese Dioxide	65-75	Not Established	Toxic if ingested
Propylene Carbonate	10-25	Not Established	
Lithium	5-10	Not Established	Highly toxic, Flammable
1, 2-Dimethoxythane	1-10	Not Established	
PHYSICAL DATA			
Boiling point	Not applicable	Specific gravity	Not applicable
Vapour pressure	Not applicable	Solubility in water	Not applicable
Odour	Not applicable	Colours	Dark
FIRE AND EXPLOSIVE DATA			
Flash point (deg C) (Method used)	Not applicable	Fammable Limit LEL UEL	
Extinguishing media	As surrounding area	Not applicable	Not applicable
Special tire-tighting procedures	Not applicable		
Unusual fire and explosion hazards	Batteries might explode due to excessive pressure build-up which might not be self-venting. Toxic fumes might be generated.		
HEALTH HAZARD DATA			
Threshold limit value	Not applicable		
LD 50 Oral	Not applicable	LD 50 Dermal	Not applicable
Skin and eye irritation	Should cells leak, the leak material will be a caustic solution. Avoid contact.		
Over-exposure effects	Not applicable		
Chemical nature	See above. There are no risks in normal use.		
FIRST AID PROCEDURES			
Eyes and skin	If leakage occurs, wash the affected area with tepid water for at least 15 minutes. If eyes are affected, wash with tepid water for at least 30 minutes. Seek medical assistance.		
Ingestion	If ingestion of leak material occurs, DO NOT induce vomiting. Give plenty of milk to drink. Obtain immediate medical assistance, stating 'Lithium Manganese Dioxide battery'.		
Inhalation	Not applicable.		
REACTIVITY DATA			
STABILITY			
Stable	Yes	Unstable	<input checked="" type="checkbox"/>
		Conditions to avoid Mechanical damage, overcharging, short circuiting terminals, charging temperatures outside the range 0 to 65° C, direct soldering. Contact with strong oxidising agents.	
Hazardous decomposition products	Thermal degradation may produce hazardous fumes of Manganese and Lithium; oxides of carbon and other toxic by-products.		
Hazardous polymerisation	Will not occur		
SPILL OR LEAK PROCEDURES			
In normal use there is no risk of leakage. If batteries are abused, this may lead to the leaking of a caustic solution which will corrode aluminium and copper. The leaking material should be neutralised using a weak acidic solution such as vinegar, or washed away with copious amounts of water.			
Contact should be avoided			
DISPOSAL			
Batteries must be disposed of according to current local regulations. Batteries should not be discarded with normal refuse.			
SPECIAL PROTECTION INFORMATION			
Respiratory	Not applicable		
Ventilation	If batteries are leaking increase ventilation		
Protective Clothing	Use Butyl gloves and safety glasses when handling leaking batteries.		
Other	_____		

APPENDIX B POWER ON SELF TESTS (POSTS) AND ERROR NUMBERS

This chapter presents Power On Self Tests (POSTs) applicable to this instrument and all Error Numbers, that may be displayed if a PC is connected to the instrument. The main topics covered are as follows:

- Power On Self Tests (POSTs) ([section B.1](#))
- Error Numbers ([section B.2](#))

B.1 POWER ON SELF TESTS (POSTS)

The results of Power On Self Tests (POSTs) can be used to pinpoint error conditions in the instrument.

This section lists, see [Table B.1](#), the Power On Self Tests (POSTs) that may be displayed via the LEDs, see [Figure B.1](#) below, on the instrument following the illumination of ALL LEDs, to signify the start of the tests.

Note If a POST failure occurs, the failed POST state will be displayed for several seconds (approximately 10 seconds) before the T2550 instrument watchdogs.

Firstly the Boot ROM is checked, running each POST to ensure the Compact Flash Memory card is functioning correctly. Each POST is then repeated checking the operation of the T2550.

Note Some POSTs are run by the Boot ROM (indicated by an extinguished 'Standby' LED). When completed the POSTs are then run by the T2550 loaded from the Compact Flash Memory card (indicated by an illuminated 'Standby' LED).

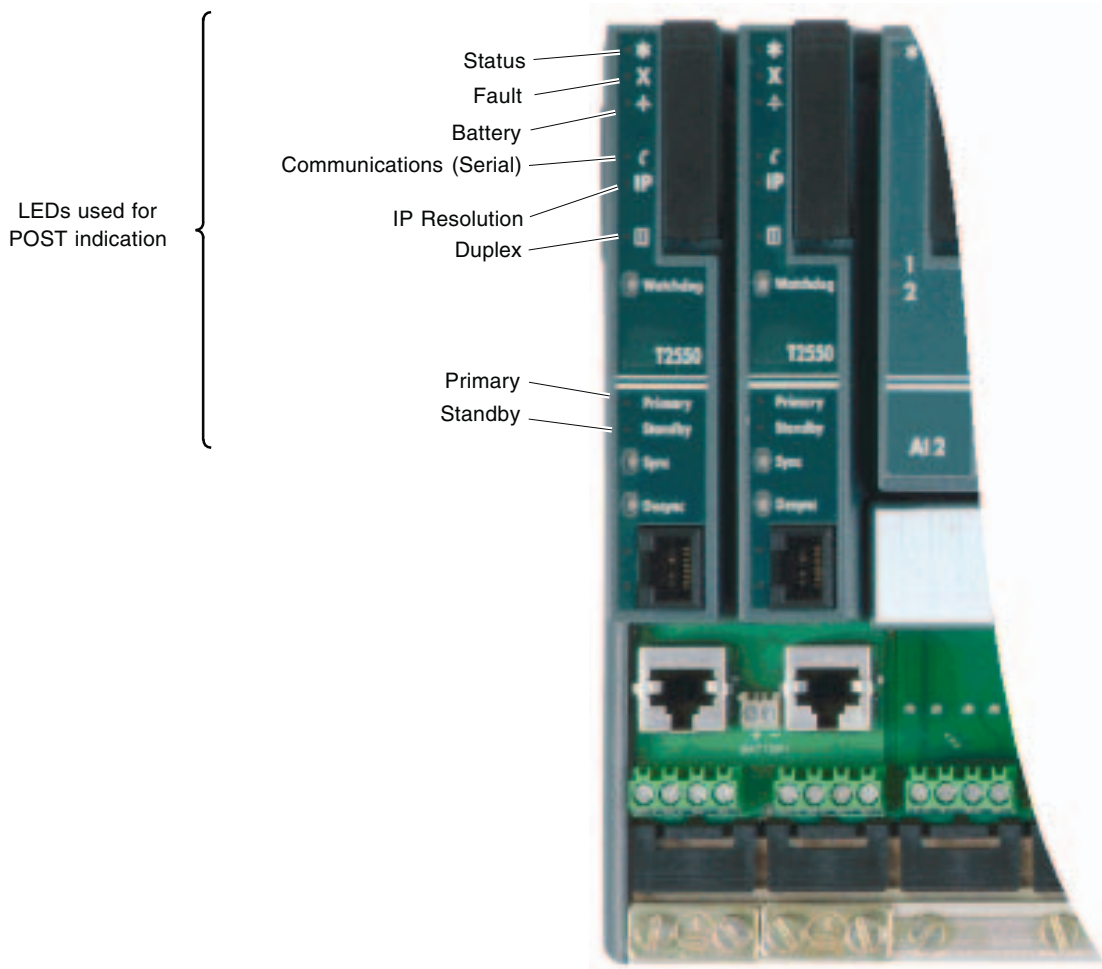























Figure B.1 Power On Self Test (POST) LEDs

B.1 Power On Self Tests (POSTs) (Cont.)

LED Pattern	Explanation	LED Pattern	Explanation	LED Pattern	Explanation
1	 <p>ALL illuminated indicates failure to use <i>SDRAM</i>. Possible cause of failure: <i>SDRAM</i> failure.</p>	8	 <p>Illuminated to show <i>Redundancy Hardware Driver</i> is being enabled.</p>	15	 <p>Illuminated when <i>Console Device</i> is initialised.</p>
2	 <p>Illuminated when <i>Serial Port Hardware</i> is initialised.</p>	9	 <p>Illuminated to show <i>SPI Driver</i> is being initialised.</p>	16	 <p>Illuminated indicates interrogation of <i>Compact Flash Card</i>. Possible cause of failure: <i>Compact Flash Card</i> fault/missing, or T2550 fault.</p>
3	 <p>Illuminated when <i>Network Hardware</i> is initialised.</p>	10	 <p>Illuminated to show <i>SPI Message Scheduler</i> is being enabled.</p>	17	 <p>Illuminated indicates the interrogation of <i>Card Information structures</i> on the <i>Compact Flash Card</i>. Possible cause of failure: <i>Compact Flash Card</i> fault, or T2550 fault.</p>
4	 <p>Illuminated to show <i>Periodic Timer Interrupt</i> is being enabled.</p>	11	 <p>Illuminated when <i>i2c Driver</i> is being initialised.</p>	18	 <p>Illuminated when <i>ATA Interface</i> is being initialised. Possible cause of failure: <i>Compact Flash Card</i> fault, or T2550 fault.</p>
5	 <p>Illuminated to show <i>Power Fail Interrupt</i> is being enabled.</p>	12	 <p>Illuminated when <i>RTC Driver</i> is being initialised.</p>	19	 <p>Illuminated when <i>ATA Driver</i> is initialised. Possible cause of failure: <i>Compact Flash Card</i> fault, or T2550 fault.</p>
6	 <p>Illuminated to show <i>Serial Port Interrupt</i> is being enabled.</p>	13	 <p>Illuminated indicates failure to match <i>LIN</i> addresses on consecutive reads. Possible cause of failure: <i>Terminal Unit</i> fault, or T2550 fault.</p>	20	 <p>Illuminated when the <i>ATA Block Device Driver</i> is generated. Possible cause of failure: <i>Compact Flash Card</i> fault, or T2550 fault.</p>
7	 <p>Illuminated to show <i>Network Hardware</i> is being enabled.</p>	14	 <p>Illuminated when the <i>hw_init_2 process</i> is complete.</p>	21	 <p>Illuminated when <i>Compact Flash Card Serial Number</i> is extracted. Possible cause of failure: <i>Compact Flash Card</i> not supplied by manufacturer.</p>

B.1 Power On Self Tests (POSTs) (Cont.)







LED Pattern	Explanation	LED Pattern	Explanation	LED Pattern	Explanation
<p>22</p> 	<p>Illuminated when <i>Disk Cache</i> for the Compact Flash Card is initialised. Possible cause of failure: Compact Flash Card fault, or T2550 fault.</p>	<p>25</p> 	<p>Illuminated indicates the <i>Filesystem</i> in the partition on the Compact Flash Card has been mounted. Possible cause of failure: Compact Flash Card fault, or T2550 fault.</p>	<p>28</p> 	<p>Illuminated to show interrupts for the <i>Ethernet interface</i> are being enabled.</p>
<p>23</p> 	<p>Illuminated when the <i>Partition Manager</i> for the Compact Flash Card is generated. Possible cause of failure: Compact Flash Card fault, or T2550 fault.</p>	<p>26</p> 	<p>Illuminated when <i>Sectors</i> on the Compact Flash Card are being <i>read or written to or from</i>. Possible cause of failure: Compact Flash Card fault, or T2550 fault.</p>		
<p>24</p> 	<p>Illuminated when the <i>Low Level Block Driver</i> for the master partition is called. Possible cause of failure: Compact Flash Card fault, or T2550 fault.</p>	<p>27</p> 	<p>Illuminated indicates the <i>Various Drivers</i> and <i>Filesystem Drivers</i> for the Compact Flash Card have been mounted. Possible cause of failure: Compact Flash Card fault, or T2550 fault.</p>		

Table B.1 Power On Self Test (POST) LED patterns

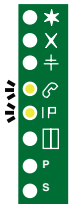
B.2 ERROR NUMBERS

This section lists the error messages that may be seen during the running of the instrument connected to a terminal, via the Ethernet port.

B.2.1 Error number structure

All error conditions have an associated 4-digit number, and usually a corresponding text message as well. Error numbers are hexadecimal 4-digit groups. The first two digits show the ‘package’ that was running when the error occurred, and the last two specify the particular error associated with that package.

RUNNING PACKAGES

Packages are defined as:

81	Base error codes (81xx) (table B.2.2a)	92	Process Redundancy Management error codes (92xx) (table B.2.2n)
82	File system (table B.2.2b)	99	External database (table B.2.2p)
83	Database system (table B.2.2c)	9A	MODBUS codes (table B.2.2r)
85	Objects system (table B.2.2d)	9B	Xec codes (table B.2.2s)
86	Trend system (table B.2.2e)	9C	Kernel items (table B.2.2t)
87	Control config (table B.2.2f)	9D	Objects (table B.2.2u)
89	Network error (table B.2.2g)	9E	Locks (table B.2.2v)
8B	Sequence database system (table B.2.2h)	A0	Machine Architecture Library (MAL) (table B.2.2w)
8C	Sequence runtime system (table B.2.2i)	A1	Application Master Comms (AMC) (table B.2.2x)
8D	Structured text system (table B.2.2j)	A4	Modbus Master Comms (MMC) (table B.2.2y)
8F	PCLIN/PC I/F package (table B.2.2k)	A6	Asynchronous I/O (table B.2.2z)
90	T1000 menu system (table B.2.2l)	AD	Profibus (table B.2.2aa)
91	Configuration files (table B.2.2m)	B2	Socket error codes (B2xx) (table B.2.2ab)

B.2.2 Error messages

Table B.2.2 lists error messages package by package.

Note. This is a complete list of all error messages generated by LIN-based systems, and therefore includes errors that are additional to those which can be generated by the instrument.

The error code FFFF means “unknown”.

8110	Timeout	8120	RTC invalid time.
8111	Received string too long (lost data)	8130	Licence Key is for different machine type
8112	Multiple tasks waiting for CIO	8131	No Licence Key in file
8113	Illegal initialisation parameters	8132	Wrong size Licence Key
8114	Rx message buffer overrun	8133	Corrupt Licence Key Header
8115	Comms hardware break detected	8134	Invalid character in Licence Key
8116	Rx character framing or parity error	8135	Error decrypting Licence Key
8117	Rx character buffer overrun	8136	Checksum error in Licence Key
8118	Tx Buffer full	8137	Licence Key not for this unit

Table B.2.2a Base error codes (81xx)

B.2.2 Error messages (Cont.)

8201	Not mounted	8212	File cannot be modified
8202	Invalid device	8213	Failed to duplicate file operation
8203	Physical error	8214	No handle to duplicate queue
8204	Not implemented	8215	File systems no longer synchronised
8205	Format error	8216	Synchronisation aborted
8206	Not present	8217	Response length error
8207	Device full	8218	File system timeout
8208	File not found	8219	File synchronisation not requested
8209	No handle	821A	Duplicate on secondary rejected
820A	Bad filename	821B	Non specific error
820B	Verify error	821C	Sync fail due to .DBF check
820C	File locked	821D	Sync fail due to .DBF load file name error
820D	File read-only or No key fitted	821E	Drive letter already assigned
820E	Unable to perform file check	821F	Filing out of memory
820F	Unable to defer another file during synchronisation	8220	Illegal link drive letter
8210	Illegal combination of open flags	8221	No such link exists
8211	Couldn't complete file operation as synchronisation is in progress	8222	Read/write file transfer to large
		8223	Read file error
		8224	Write file error

Table B.2.2b File system error codes (82xx)

8301	Bad template	834C	Connection Destination not I/P
8302	Bad block number	834D	No free connection resources
8303	No free blocks	834E	Bad conn. src/dest block/field
8304	No free database memory	834F	Invalid connection destination
8305	Not allowed by block create	8350	Hot/Cold start switch is disabled
8306	In use	8351	No database was running
8307	Database already exists	8352	Real-time clock is not running
8308	No spare databases	8353	Root block clock is not running
8309	Not enough memory	8354	Coldstart time was exceeded
8320	Bad library file	8355	Root block is invalid
8321	Bad template in library	8356	Too many control loops
8322	Bad server	8357	Coldstart switch is disabled
8323	Cannot create EDB entry	8360	Unsynchronised Block Types
8324	Bad file version	8361	DB/Filing system mismatch
8325	Bad template spec	8362	Unsynchronised Secondary
8326	Unable to make block remote	8363	Operation forbidden whilst CPUs synchronising/changing over
8327	Bad parent	8364	Pwr-up data inhibits run
8328	Corrupt data in .DBF file	8365	POST hardware failure
8329	Corrupt block spec	8366	Not fixed function strategy
832A	Corrupt block data	8367	Default strategy missing
832B	Corrupt pool data	836A	Not duplex instrument
832C	No free resources	8370	On Line Reconfig in progress
832D	Template not found	8371	No delta changes to try/discard
832E	Template resource fault	8372	No delta changes to untry/apply
8330	Cannot start	8373	On Line Reconfig not supported
8331	Cannot stop	8380	Duplicate block name whilst loading database
8332	Empty database	8390	This is an Invalid Unit (not permitted to run databases)
8333	Configurator in use or device busy	8391	This unit does not support Licence Control System
8340	.DBF file write failed	8392	Runtime save not supported on this unit.
8341	More than one .RUN file found	8393	Reconfig not permitted for this block type.
8342	.RUN file not found		
834A	Connection Source is not an O/P		
834B	Multiple connection to same I/P		

Table B.2.2c Database system error codes (83xx)

B.2.2 Error messages (Cont.)

8501	Out of F RAM - DO NOT save file
8502	Out of N RAM - DO NOT save file

Table B.2.2d Objects system error codes (85xx)

8602	Bad channel number
8603	Bad type code
8611	Bad handle or not hist
8613	File exists
8614	Exceeded global limit
8615	Unexpected end of file
8616	Read error
8617	Write error
8619	Bad filename
861A	Bad timestamp

Table B.2.2e Trend system error codes (86xx)

8701	Unnamed blocks
8702	Cannot save compounds
8703	No root block
8704	.GRF file write failed
8705	Compounds too deep
8706	Unused GRF block - deleted
8707	Unused GRF connection - deleted
8708	Missing GRF block - added
8709	Missing GRF connection - added
870A	Unknown DBF/GRF block mismatch
870B	Unknown DBF/GRF connect mismatch
870C	DBF/GRF file mismatch - use FIX

Table B.2.2f Control config error codes (87xx)

8901	Network timeout
8902	Rejected by local node
8903	Rejected by remote node
8904	Not implemented
8905	Not active on local node
8906	Not active on remote node
8907	Transmit failure
8908	Failed to get memory
8909	Decode packet
890A	Remote file system busy
890B	Illegal TEATT
890C	Wrong TEATT
890D	NServer is busy
890E	TEATT not owned
890F	Duplicate block
8910	TEATT rejected
8911	Port disabled
8912	No port configuration
8913	Bad network filename
8999	Network node invalid

Table B.2.2g Network error codes (89xx)

8B01	Object Overload
8B02	Text Overload
8B03	No Matching Step Name
8B04	No Matching Action Name
8B05	Step already Exists
8B06	Action already Exists
8B07	Link already Exists
8B08	Leave a Bigger Gap
8B09	Bad Time Format
8B0A	File Read Error
8B0B	File Write Error
8B0C	File doesn't Exist
8B0D	File not Open
8B0E	Create Action ?
8B0F	No Match with string
8B10	No More Matches
8B11	Match found in Transition
8B12	Match found in Action
8B13	Changed - Are you sure ?
8B14	Link Already Exists
8B15	Illegal Chars in Name
8B16	Action Did Not Compile
8B17	Fatal Memory Overflow - Quit Now!
8B18	Out of memory when compiling
8B19	Root action must be SFC
8B1A	Invalid actions found during compilation
8B1B	Invalid DB name
8B1C	No database loaded
8B1D	Map is invalid

Table B.2.2h
Sequence data base system error codes (8Bxx)

8C01	Database not Running
8C02	No Sequences Loaded
8C03	Sequence is being displayed
8C04	Cannot find an SFC_DISP block
8C05	Cannot find Source File
8C06	Sequence Not Loaded

Table B.2.2i Sequence runtime error codes (8Cxx)

B.2.2 Error messages (Cont.)

8D01 Syntax Error	8D0F "String" > 8 chars
8D02 Statement expected	8D10 End quotes expected
8D03 Assignment expected	8D11 Bad Number
8D04 THEN expected	
8D05 no ELSE or END_IF	8D20 Can't jump backwards
8D06 END_IF expected	8D21 Unresolved jump
8D07 ";" expected	8D22 Too many jump labels
8D08 Bad bracket matching	8D23 Jump target is blank
8D09 Identifier too long	8D24 ", " expected
8D0A Bad identifier	8D25 Transition must be single rung
8D0B Unrecognised symbol	8D26 Transition must be Normally Open coil
8D0C Code Buffer Full	8D27 Syntax error in literal
8D0D Expression expected	8D28 Incomplete Rung
8D0E Can't find this name	8D29 Bad label

Table B.2.2j Structured text error codes (8Dxx)

8F01 PCLIN Card not responding
8F02 PCLIN Request failed
8F04 EDB not known or not external
8F07 Unknown EDB
8F0A Unable to delete ED
8F14 Bad block number
8F15 Template mismatch
8F16 Block failed to attach
8F17 Block failed to detach

Table B.2.2k PCLIN/PC I/F package error codes (8Fxx)

9001 Invalid PIN
9002 PINs do not match - unchanged
9003 Invalid PIN - reset to 1234
9004 Access denied
9005 Invalid default security info
9006 Invalid DTU A security info
9007 Invalid DTU B security info

Table B.2.2l T1000 menu system error codes (90xx)

9100 Couldn't open config file
9101 Section not found
9102 Parameter not found
9103 Argument not found
9104 Config area too small
9105 Config file syntax error
9106 Config header corrupted
9107 Not a number
9108 Out of memory

Table B.2.2m Configuration files error codes (91xx)

9201 Unit is not currently synchronised
9202 Unit is currently synchronised
9203 (De)Sync already initiated
9204 Secondary has inferior I/O status
9205 Secondary has inferior LIN status
9206 Primary & Secondary have mismatched LIN protocol versions
9207 Primary & Secondary have mismatched LIN types
9208 Primary & Secondary have mismatched DCM libraries
9209 Primary & Secondary have mismatched ELIN protocol names
920A On-Line Reconfig changes are pending
920B Timeout waiting for status from secondary
920C Timeout waiting for secondary's state machine to terminate
920D Secondary failed to respond to sync start request
920E Secondary failed to achieve file synchronisation
920F Timeout waiting for file synchronisation
9210 Secondary failed to load database
9211 Secondary failed to run database
9212 Database sync cycle failed
9213 Secondary failed to complete synchronisation

Table B.2.2n Process Redundancy Management error codes (92xx)

9901 No EDB's left
9902 EDB already exists
9903 Invalid EDB

Table B.2.2p External database error codes (99xx)

B.2.2 Error messages (Cont.)

9A01	Invalid Second Register
9A02	Not a 32 bit field type
9A03	Invalid Scan Count
9A04	Incorrect Modbus function types
9A05	Invalid register position
9A06	Second register of 32 bit pair
9A07	Invalid register type

Table B.2.2r MODBUS error codes (9Axx)

9B01	Illegal unique task id
9B02	Task id already being used
9B03	No more task control blocks
9B04	Out of XEC memory
9B64	Task aborted
9B65	Task timeout

Table B.2.2s Xec error codes (9Bxx)

9C01	Already registered
9C02	Too many kernel users
9C03	Couldn't allocate the local storage that was required
9C04	Error changing priority
9C05	Need to supply an instance name
9C06	Failed to get platform info
9C07	Platform not known
9C33	Feature not implemented (QUE)
9C34	Insufficient memory supplied (QUE)
9C35	Size of data for read or write invalid (QUE)
9C36	Unable to write to queue
9C37	Unable to read from queue
9C38	Unable to allocate memory (QUE)
9C65	No Kernel instance to make intra-signal unique
9C66	Signal already exists
9C67	Failed to create signal
9C68	Failed to open signal
9C69	Failed to close signal
9C6A	Timeout waiting on signal

Table B.2.2t Kernel items (9Cxx)

9D01	Object already exists
9D02	Out of objects
9D03	Object does not exist
9D04	Bad invocation parameter
9D05	Object handle is now stale
9D06	Object handle is invalid
9D07	Too many users of object

Table B.2.2u Objects error codes (9Dxx)

9E01	Lock has entered an inconsistent state and cannot be granted
9E02	Lock was not granted in the required mode
9E03	Timeout attempting to acquire
9E04	Unable to convert mode of lock
9E05	Already hold a read lock
9E06	Already hold a writer lock
9E07	Do not hold a read lock
9E08	Do not hold a writer lock
9E09	Write lock detected during read unlock
9E0A	Reader lock detected during write unlock
9E0B	Unable to grant read to write conversion as a conversion of this form is already in progress
9E0C	Unable to represent user in lock control structures
9E0D	lck_Unlock invoked but not enabled
9E0E	Nesting requested but lock not a mutex
9E0F	Overflow of nested mutex
9E10	Unable to convert a nested mutex

Table B.2.2v Locks error codes (9Exx)

A001	Could not create user's event (MAL)
A002	Could not open user's event (MAL)
A003	Could not set user's event (MAL)
A004	Unable to grant system wide mutex due to it being in an inconsistent state
A005	Unable to grant system wide mutex due to a timeout
A006	Unable to grant system wide mutex reason unknown
A007	Unable to grant system wide mutex as not created
A008	Unable to suspend user (MAL)
A009	Unable to allocate memory (MAL)
A00A	Unable to change priority (MAL)
A00B	Error waiting on signal (MAL)
A00C	Error releasing signal waiters (MAL)

Table B.2.2w MAL error codes (A0xx)

B.2.2 Error messages (Cont.)

A101 Cyclic comms enabled on node(s)	A10A Conflict
A102 No memory left	A10B Task not running
A103 Bad info given	A10C Bug
A104 Data is referenced	A10D Manual cyclic only (pmc reject)
A105 No data group installed	A10E Cannot add cyclic request
A106 Pending message	A10F Slave rejected cyclics
A107 Fault external to AMC	A110 No pmc callback
A108 Not supported	

Table B.2.2x AMC error codes (A1xx)

A401 Out of / Bad resource(s)	A40F No Modbus TCP connection
A402 Bad info supplied	A410 Asynchronous Modbus TCP buffer appears invalid
A403 Pending message	A411 Cannot issue an asynchronous Modbus transaction over serial line
A404 Problem external to MMC	A412 Asynchronous Modbus transaction in progress to this node
A405 Not supported	A413 Modbus TCP device has disconnected
A406 Timeout	A414 Modbus TCP transaction mismatch
A407 Frame parity error	A415 Modbus TCP error reading/writing socket
A408 Corrupt message	A416 Asynchronous Modbus TCP not supported
A409 Link protocol error	A417 Out of Modbus TCP sessions
A40A Modbus exception recvd	A418 TCP connection in progress
A40B Tx fail	A419 No instrument number to Modbus node address
A40C No Modbus TCP configuration file	A41A Waiting to form Modbus TCP connection
A40D Modbus TCP device already configured	
A40E Modbus TCP node not configured	

Table B.2.2y MMC error codes (A4xx)

A601 Asynchronous I/O in progress
A602 No asynchronous I/O in progress
A603 Not yet implemented
A604 Tx operation complete but not all characters transferred
A605 Rx operation complete, but not all characters received
A606 Event not unique
A607 General CIO error
A608 No asynch. operation fetched
A609 Out of serial lines
A60A Unable to allocate the requested line
A60B Failed to submit asynchronous I/O
A60C Input/output timed out
A60D Indeterminate error during fetch
A60E I/O timed out but failed to cancel operation in progress

Table B.2.2z Asynchronous I/O error codes (A6xx)

B.2.2 Error messages (Cont.)

AD01	Cyclic data not available	AD20	Not used
AD02	Cannot make cyclic into acyclic	AD21	Unable to set master protocol params.
AD03	Profibus C1 not allowed	AD22	Unable to set master comms params.
AD04	Profibus C2 not allowed	AD23	Unable to set slave comms params.
AD05	Acyclic frag. limit exceeded	AD24	Failed to start profibus line task
AD06	Comms line requested is not profibus	AD25	Failed to stop profibus line task
AD07	Resource alloc failure	AD26	Bad slave diagnostic
AD08	PMC not initialised	AD27	Acyclics restarted
AD09	No more Cyclic data space	AD28	Master rejected acyclic req.
AD0A	No more cyclic tag space	AD29	Master acyclic resp. error
AD0B	Attempt to append while running	AD2A	Slave acyclic req. rejected
AD0C	Data attribs. not set	AD2B	Slave acyclic resp error
AD0D	Data group size / type mismatch	AD2C	Acyclic timeout
AD0E	Data group size / type unknown	AD2D	No slave acyclic resp.
AD0F	Data group wrong line number	AD2E	Failed to get diags.
AD10	Data group node addr. wrong	AD2F	Failed to get slave diags.
AD11	Data group addresses not contiguous	AD30	No slave diags. available
AD12	Not in assembling mode	AD31	Bad pointer parameter
AD13	Cyclics not configured	AD32	Parameter out of range
AD14	Cyclics not running	AD33	Slave cfg overflow
AD15	Attempt to change card state	AD34	Slave prm overflow
AD16	Bad data group list	AD35	C1 acyclic data too big
AD17	Changeover not complete	AD3C	C2 acyclic data too big
AD18	Acyclics not ready	AD37	Slave not running
AD19	Too many diag. clients	AD38	Pending acyclic
AD1A	Line already initialised	AD39	C2 RW not supported by slave
AD1B	Comms attribs ptr failure	AD3A	C2 unexpected connection close
AD1C	Comms attribs data failure	AD3B	Master card startup error
AD1D	Cannot achieve cycle time	AD3C	Not used
AD1E	Master baud rate not supported	AD3D	Could not get slave IO data
AD1F	Cannot kill cards DB	AD3E	Slave not running at changeover

Table B.2.2aa Profibus error codes (ADxx)

B201	Error doing select	B210	Record does not contain a valid length field
B202	Error accepting connection	B211	Unable to read record as insufficient buffer was supplied
B203	Out of connections	B212	Incomplete record encountered
B204	Error reading socket	B213	Connection closed
B205	Failed to initialise sockets	B214	Timed out receiving on socket
B206	Connection has been reset	B215	Error sendint over socket
B207	Unable to listen on socket	B216	Send would block on socket
B208	Could not allocate socket	B217	Could not establish blocking mode
B209	Could not get host information	B218	Sockets out of memory
B20A	Could not bind socket	B219	Peek buffer is full
B20B	Unable to connect socket	B21A	Global initialisation failed
B20C	Reference is not a valid connection	B21B	Connection timed out
B20D	Failed to send data over connection	B21C	Socket session still active
B20E	Insufficient buffer for connection data	B21D	The session name is being used
B20F	Cannot peek for records		

Table B.2.2ab Socket error codes (B2xx)

APPENDIX C TERMINAL CONFIGURATOR

This explains the complexities of using the Terminal Configurator program resident on the instrument.

The main topics of this chapter are:

- The Configurator ([section C.1](#))
- Running the Configurator ([section C.2](#))
- LIN Database configuration ([section C.3](#))
- Modbus configuration ([section C.4](#))

C.1 THE CONFIGURATOR

Most configuration will be done before despatch, using the LINtools software package. This chapter explains how LIN Databases and communications parameters are configured for the instrument using the Configurator program resident within the instrument.

The Configurator program is mainly for adjusting existing configurations on site, usually to accompany modifications to the processing plant and can also be used to 'Load', 'Start', 'Stop', 'Save' and 'Monitor' LIN Databases, to perform various filing operations and 'Try' and 'Untry' changes to the running control strategy.

It employs the standard LIN function block structured approach. The *LIN Blocks Reference Manual* (Part no. HA082375U003) gives full details of the software LIN function blocks available for the control strategy, and how to configure the parameters.

Note. Instruments operating in redundant configuration will not allow function blocks to be added or deleted unless Primary and Secondary are synchronised.

C.1.1 Configurable Items

The configurable items are configured using a menu/item selection procedure. Configuration of the LIN Database consists of carrying out one or more of the following:

- Installing function blocks in the running control strategy (MAKE)
- Creating duplicates of existing LIN function blocks (COPY)
- Deleting function blocks (DELETE)
- Inspecting and updating function blocks (INSPECT)
- Test changes to the running control strategy (TRY)
- Cancel the test, but keep the changes displayed on the Configurator (UNTRY)
- Accept changes to the running control strategy (APPLY)
- Cancel all changes to the running control strategy and return to last operational LIN Database (UNDO)
- Accessing the Utilities menu (UTILITIES), from which the user can START and STOP programs, SAVE and LOAD LIN Databases, and access the ELIN setup page

C.2 RUNNING THE CONFIGURATOR

This section describes accessing and quitting the Configurator using a ‘Telnet’ session with HyperTerminal®. If a different terminal program is used, its user documentation should be consulted (if necessary) for the equivalent procedures.

Note. HyperTerminal® is the only recommended method of accessing the Configurator. Other methods of accessing the Configurator may result in unforeseen consequences.

C.2.1 Initial menu access

Using Windows™ XP as an example,

1. Power up the PC and start HyperTerminal® (Programs > Accessories > ... > HyperTerminal®). A ‘new connection’ sign-on screen appears.
2. Enter a name for the link and accept using the OK button. This will now reveal a Connect to dialog.
3. In the Connect using drop-down, select the TCP/IP (Winsock) option. After selection the fields above this drop-down now displays a Host and Port number field.

Note. The Configurator will only operate correctly if the VT100 is defined in the Emulation field, File > Properties > Settings page.

4. After entering appropriate values to each of the required fields and confirming the changes, the sign-on screen will appear.
5. Press 1 to display the Initial menu, see Fig C.2.1b.

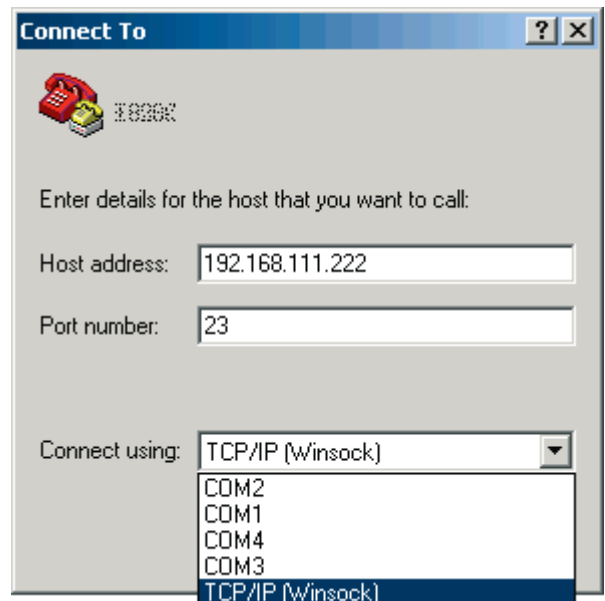

```
Telnet 149.121.165.188

Total Machine Control - 1/0 at 66 MHz
(Hardware Build: RS485)
Serial number = 1426
Ethernet (MAC) address = 00:E0:4B:00:45:DA
IP address = 192.168.111.222
Subnet mask = 255.255.255.0
Default gateway = 0.0.0.0
POST result (0000) = SUCCESS
Last shutdown because: Successful Power Down

1 ANSI-CRT
>>>
```

Figure C.2.1a Typical sign-on screen

- Ethernet (MAC) address Shows the address of the Ethernet interface. This value is unique and is permanently fixed for an individual instrument.
- IP address Gives the IP address currently assigned to this instrument.
- Subnet Mask Gives the subnet mask currently assigned to this instrument. An IP host uses the subnet mask, in conjunction with its own IP address, to determine if a remote IP address is on the same subnet (in which case it can talk directly to it), or a different subnet (in which case it must talk to it via the Default Gateway).
- Default Gateway Gives the IP address of the Default Gateway. It is the address via which this instrument must talk in order to communicate with IP addresses on other subnets. If undefined (0.0.0.0 or blank) then this instrument can only talk to other IP hosts on this same subnet.

Note. Refer to the ELIN User Guide (Part no. HA082429) for full details.

® Hyperterminal is a trademark of Hilgraeve Inc.

C.2.1 INITIAL MENU ACCESS (Cont.)

If Modbus is enabled, the Configurator *Initial menu* appears, see Figure C.2.1b. If Modbus is disabled, the *Main menu* appears instead, as shown in [Figure C.3](#).

```

INIT      Choose option

                >DATABASE - General configuration
                GATEWAY  - MODBUS configuration
    
```

Figure C.2.1b Initial menu

Note. If the Initial or Main menu appears, this indicates that the instrument has entered configuration mode.

Locate the cursor (>) at a menu item using the cursor keys, then press <Enter> to display the next level in the menu hierarchy. This is called *selecting* an item. In general, to access the next lower level of the menu hierarchy <Enter> is pressed. To return to the next higher level menu or close a ‘pop-up’ options menu the <Escape> key is pressed. <PageUp> and <PageDown> allow hidden pages in long tables to be accessed.

Note. The next lower level of menu hierarchy can be accessed directly by simply pressing the initial letter of the menu item, e.g. on the Configurator initial menu above, pressing ‘G’ will select the GateWay menu item.

Function	Key combination
Redraw screen	<Ctrl> + W
Cursor Up	<Ctrl> + U
Cursor Down	<Ctrl> + D
Cursor Left	<Ctrl> + L
Cursor Right	<Ctrl> + R
Page Up	<Ctrl> + P
Page Down	<Ctrl> + N
Stop automatic update	<Ctrl> + V

Table C.2.1a Cursor-control - equivalent key combinations

For keyboards without cursor-control keys, equivalent ‘control’ character combinations may be used, as indicated in Table C.2.1a. To use these, the <Ctrl> key is held down and the specified character typed.

Some tables allow a value to be entered directly, or via a called-up menu. For direct entry, the first character(s) of the chosen option is (are) typed, followed by <Enter>. Alternatively, the menu can be accessed with <Enter> or <Tab> as the first character after the field is selected.

C.2.2 The Initial menu

The Initial menu, [Figure C.2.1b](#), lists two options - *Database* and *Gateway*. Database allows access to the Main menu for configuring a LIN Database, see [Database Configuration section](#). Gateway allows access to the GateWay menu, for setting up a Modbus configuration.

C.2.3 Quitting the Terminal Configurator

The instrument automatically exits configuration mode when the ‘Telnet’ session is closed.

Note. If the Configurator is left running but unused, the user will eventually be locked out of the online operations, including Download, Start and Stop, and Online Reconfiguration.

C.3 LIN DATABASE CONFIGURATION

Most LIN Database configuration is completed before despatch, using the LINtools configuration tool. However, this basic Terminal Configurator is resident within the instrument allowing configuration of a LIN database from an appropriately configured PC.

When attempting to edit a control strategy that is running, only limited commands can be used, see [Configurable Items section](#). The commands are accessed from the 'Utilities' menu, and permit 'Tentative' changes in a running control strategy. The 'Tentative' changes can be tested ('TRY' command) and accepted ('APPLY' command) if the required output is received. Continual changes can be attempted or discarded ('UNTRY' command) until the required value is obtained.

START USING THE TERMINAL CONFIGURATOR

Following the successful start of a 'Telnet' session, and access from the Initial Menu, the Main menu appears.

Figure C.3 shows the Main menu.

MAIN MENU	Select option
	>MAKE - Create block
	COPY - Copy block
	DELETE - Delete block
	INSPECT - Inspect block
	NETWORK - Network setup
	UTILITIES - Engineering utilities
	ALARMS - Current Alarms

Figure C.3 Configurator Main menu

C.3.1 MAKE command

Installs function blocks in the control strategy. Select MAKE to display the SET MENU, the instrument resident library of function block categories, as detailed in the *LIN Block Reference Manual* (Part no. HA082375U003).

[Figure C.3.1a](#) shows part of the screen display when LOGIC is selected, as an example.

Note. Every control strategy must contain a 'header' block, the only LIN function block initially available for a new control strategy.

Select a category to list its function blocks. Select the function block to be installed. The function block *Overview* appears listing the function block parameters, default values and units in a double 3-column format. [Figure C.3.1b](#) shows the (default) overview for the PID block as an example.

Note. Any function blocks added while the control strategy is running, online, are made as 'Tentative'. They will not become part of the running control strategy until either 'TRY' or 'APPLY' is selected from the Utilities menu.

LOGIC	Select type
	> PULSE
	AND4
	OR4
	XOR4
	LATCH
	COUNT
	COMPARE

Figure C.3.1a Logic category menu

C.3.1 MAKE command (Cont.)

BLOCK OVERVIEW

Refer to [Figure C.3.1b](#), which shows the main features of a typical function block overview, used to monitor and update function block parameters. (Overviews can also be accessed via the COPY and INSPECT main menu options.) The overview is equivalent to a LINtools *Object Properties pane* and its fields have the same meanings, although data entry is different.

Note. Parameters being updated by incoming connections from other function blocks are not specially indicated in a function block overview.

Title Bar	OVERVIEW				Block: "NoName"	Type: PID	DBase:
	----- Tentative -----						
Tentative indication	Mode	AUTO			Alarms		
	FallBack	AUTO					
	PV	0.0	Eng		HAA	100.0	Eng
	SP	0.0	Eng		LAA	0.0	Eng
	OP	0.0	%		HDA	100.0	Eng
Data Fields	SL	0.0	Eng		LDA	100.0	Eng
	TrimSP	0.0	Eng		TimeBase	Secs	
	RemoteSP	0.0	Eng		XP	100.0	%
	Track	0.0	%		TI	0.000	
					TD	0.000	
Underline Cursor	HR_SP	<u>100.0</u>	Eng		Options	00001100	
	LR_SP	0.0	Eng		SelMode	00000000	
	HL_SP	100.0	Eng				
	LL_SP	0.0	Eng		ModeSel	00000000	
	HR_OP	100.0	%		ModeAct	00000000	
	LR_OP	0.0	%				
	HL_OP	100.0	%		FF_PID	50.0	%
	LL_OP	0.0	%		FB_OP	0.0	%

Figure C.3.1b Overview - PID block

TITLE BAR

Contains fields common to all overviews: *Block*, *Type*, and *DBase*. Details of these fields are to be found in the *LIN Blocks Reference Manual* (Part no. HA082375U003). A blank *DBase* field denotes that the LIN Database is local.

Note. A function block is not added to the control strategy until (at the minimum) a block name has been assigned, i.e. tagname, and either the LIN Database has been restarted or APPLY operated in the Utilites menu. Using the TRY command will temporarily add the function block, until it is cancelled, using the UNTRY command.

OVERVIEW DATA FIELD ENTRY

To update a parameter field, locate the flashing 'underline' cursor () at the field using the arrow keys, then proceed as described next for the different data field types. Some data fields display further nested levels of data when entered, as detailed in the following sections. Press <Enter> to access a deeper level; press <Escape> to return to a higher level.

C.3.1 MAKE command (Cont.)

1 User-defined names.

Type in a name (8 characters max.) and press <Enter> to overwrite existing data. To insert characters, locate the cursor at the character to follow and type the insertions. A ‘beep’ warns that excess characters have been typed. To abort the current entry and leave the LIN Database unchanged, move the cursor to a function block field above or below the current field *before* pressing <Enter>, or press the <Escape> key.

Pressing <Enter> with the cursor on the first character of the *Block* or *DBase* fields (before starting to type) accesses a *Full Description* page (Figure C.3.1c shows an example). This page gives general information about the function block and has a common format.

FULL DESCRIPTION	Block: INP01	Type: ANIN
Request refresh		0.1040
Actual refresh		0.105
Server number		3
DBase:		=Alpha
Rate ms		10
Execute time		1234

Figure C.3.1c FULL DESCRIPTION page for block (example)

- Block Block tagname (Read/write)
- Type Block type (Read-only).
- Request refresh Configured time period (secs) for running the LIN function block. (Read-only).
- Actual refresh Time period (secs) since the function block was last run. (Read-only).
- Server number Function block’s time scheduled task priority (Read/write). There are four User Tasks numbered from User Task 1 (highest priority) to User Task 4 (lowest priority).
- DBase: Name of the function block’s LIN Database. A blank field denotes the LIN Database is local, i.e. is resident in this instrument. (LIN Database names and their LIN addresses are specified via the main menu NETWORK option, see [Network section](#)) (Read/write).

Note. Remote LIN Database names entered in the DBase field must be prefixed by an ‘equals’ sign (=).

- Rate ms Rate is the minimum update period (i.e. maximum rate) at which an individual cached function block is transmitted across the Local Instrument Network (LIN). The default is 10ms minimum, i.e. 100Hz maximum. Rate can be set between 10ms and 64s.

Note. Rate values are minimum update times only. Heavily loaded networks may not be able to reach the faster update rates.

- Execute time This is the time taken in microseconds to execute a LIN function block (including connections etc.).

Note. If the control strategy is running (online), the ‘DBase’ and ‘Rate ms’ fields cannot be edited. Only local function blocks can be made.

C.3.1 MAKE command (Cont.)

2 Parameter values.

Type in a value and press <Enter> to update the LIN Database. (Read-only parameters do not accept new values.) The instrument automatically adds a following decimal point and padding zeros if needed, but before a decimal point a zero must always be typed, e.g. 0.5, not .5.

Pressing <Enter> with the field selected, before starting to type, accesses a *Full Description* page for the parameter (Figure C.3.1d shows an example).

FULL DESCRIPTION	Field: PV	Block: PID_1	Type: PID
Value	80.1		Real32
Input	SIM 1.OP		

Figure C.3.1d FULL DESCRIPTION page for parameter (example)

Field, Block, Type Read-only fields

Value Parameter value, editable as for the Overview. (Read/write)

Real32 Value type (Real32 = floating point number) (Read Only)

Input Defines the source of any connection to the parameter from another function block, as Block Tagname.Output Mnemonic. A blank function block field means no connection. To make or edit a connection, type in the source function block tagname and output mnemonic, e.g. SIM 1.OP, or SEQ.DIGOUT.BIT3), then press <Enter>. Invalid data is 'beeped' and is not accepted. The field is not case sensitive. To delete a connection, type <space> then press <Enter>. (Read/write)

Note. See CONNECTION TYPES... (below) for information and advice on types of LIN Database connections.

3 Parameter units.

Type in a value and press <Enter>. All other related units in the LIN Database automatically copy the edited unit. Pressing <Enter> with the field selected, before starting to type, accesses the parameter *Full Description* page (as for the value field).

C.3.1 MAKE command (Cont.)

4 Options menu fields

Press <Enter> to display a pop-up menu of options for the field. Figure C.3.1e shows an example (PID Mode) in part of an *Overview* page.

OVERVIEW		Block: PID_1	Type: PID	DBase:	
Mode	AUTO			Alarms	
FallBack	> MANUAL			HAA	100.0 Eng
	AUTO		Eng	LAA	0.0 Eng
PV	REMOTE		Eng	HDA	100.0 Eng
SP	F_MAN		%	LDA	100.0 Eng
OP	F_AUTO		Eng		
SL			Eng	TimeBase	Secs
TrimSP			Eng	XP	100.0 %
RemoteSP	0.0		Eng	TI	0.00
Track	0.0		%	TD	0.00
HR_SP	100.0		Eng	Options	00101100
LR_SP	0.0		Eng	SeMode	00000000
HL_SP	100.0		Eng	ModeSel	00000000
LL_SP	0.0		Eng	ModeAct	00000000
HR_OP	100.0		%	FF_PID	50.0 %
LR_OP	0.0		%	FB_OP	0.0 %
HL_OP	100.0		%		
LL_OP	0.0		%		

Figure C.3.1e Pop-up options menu (example)

A quicker alternative to accessing the pop-up options menu is to type the required option, or enough of its *initial letters* to uniquely specify it, directly into the selected field and then press <Enter>. E.g. entering just **M** selects MANUAL; entering **F_M** selects F_MAN (Forced Manual).

5 Alarms field.

Press <Enter> to display a 4-column *Alarms* page listing alarm name (e.g. HighAbs), acknowledgement (e.g. Unackd), status (e.g. Active), and priority (0 to 15). Update the acknowledgement or priority fields (the only editable ones) by typing in a value and pressing <Enter>. (Any single letter can be used for the acknowledgement field.) Figure C.3.1f shows an example *Alarms* page.

Alarms	Block: PID_1	Type: PID	
Software	Unackd	Active	15
HighAbs	Unackd	Active	15
LowAbs			0
HighDev		Active	10
LowDev			2

Figure C.3.1f Alarms page (example)

C.3.1 MAKE command (Cont.)

6 Bitfields

Contain eight (or sixteen) binary digits showing the logic states of a corresponding set of up to eight (or sixteen) parameters. To edit the bitfield directly, type in a bit-pattern then <Enter> it. Alternatively, press <Enter> to display a *Full Description* page listing the parameter TRUE/FALSE or HIGH/LOW states (in the same format used for LINtools *Object Properties pane* bitfields). Figure C.3.1g shows an example. Alter a logic state by locating the cursor on the state, typing in T(rue) or F(alse), and pressing <Enter>. (A bit may be read-only.)

FULL DESCRIPTION	Field: ModeAct	Block: PID_1	Type: PID
NotRem	<u>TRUE</u>		
HoldAct	FALSE		
TrackAct	FALSE		
RemAct	FALSE		
AutoAct	TRUE		
ManAct	FALSE		
FAutoAct	FALSE		
FManAct	FALSE		

Figure C.3.1g Full Description page for bitfield (example)

To connect an input to a bitfield, press the → key and type in the LIN function block name/field name from which the connection is to be made. A connection can be deleted simply by replacing the LIN function block name/field name in the bitfield with a <space>.

Caution

Any connections deleted while the control strategy is running (online), are marked as 'DeleteReq'. It can be edited further by adding a different connection to the bitfield. However, this new connection will not be used, and the existing connection remains part of the running control strategy until either 'TRY' or 'APPLY' is selected from the Utilities menu.

Note: See CONNECTION TYPES... (below) for information and advice on types of LIN Database connections.

7 Two- and four-digit 'combined' hexadecimal status fields.

Hex fields are marked with a '>' sign and have the same format and significance as those found in LINtools specification menus. The digits show the logic states of a corresponding set of parameters, up to four per hex digit. To edit the field directly, type in new values then press <Enter>. Alternatively, press <Enter> to display a *Full Description* page listing the parameter TRUE/FALSE states and edit this list (as described for Bitfields, above).

CONNECTION TYPES IN A LIN INSTRUMENT DATABASE

There are three types of connection used in a LIN Database: local connections, connections writing to a cached function block, and connections from a cached function block to a local function block. The following explains how and when they are evaluated.

1 Local connections.

These are connections between two function blocks that are both local to the LIN Database. The connection is always evaluated immediately prior to the execution of the destination LIN function block's update procedure, regardless of whether the source data has changed between iterations. With this sort of connection, any attempt to write to the connection destination is immediately 'corrected' by the next connection evaluation.

C.3.1 CONNECTION TYPES IN A LIN DATABASE (Cont.)

- 2 Connections to cached function block.
 These are connections whose destination function block is a cached copy of a function block in another instrument. The source of the connection can be either a local function block or another cached function block. Such connections are evaluated only if the source and destination data do not match. All cached function blocks in the LIN Database are processed at regular intervals, and whenever a change is detected a single field write is performed over the communications link.
- 3 Connections from cached function block to local function block
 These are connections where the source function block is a cached copy of a function block in another instrument, and the destination function block is local to the LIN Database. All cached function blocks in the LIN Database are tested at regular intervals, and if a change in the function block data is detected, then all such connections out of the cached function block into local function blocks are evaluated. The connections are not evaluated if the source data has not changed. These connections minimise the load involved in synchronising the LIN Databases of a duplex pair, whilst ensuring the coherence of the data between the primary and secondary instruments.

Caution

With this third type of connection, tasks are allowed to write to the connection destination, leaving the source and destination of the connection with different values. You should ensure that your strategy does not write to connection destinations.

C.3.2 COPY command

Creates duplicates of existing function blocks. Select COPY from the main menu to display all the function blocks in the control strategy, in semi-graphical format as shown in Figure C.3.2. The function blocks are displayed from left to right in order of creation. Move the cursor (>) to a function block and press <Enter>. The function block is duplicated and added to the strategy, and its Overview page automatically appears ready for parameterising. The duplicate retains all the original parameter values except for the *Block* field, which has the default tagname “NoName”. Input connections are not copied; nor are I/O function block site numbers.

```

COPY  Select block
      +-----+-----+-----+-----+-----+
      >T2550   SIM_1   TIC_100  PID_1   FIC_101
      +-----+-----+-----+-----+-----+
    
```

Figure 8.3.2 COPY display (example)

Pressing <Escape> returns the COPY display, where the copied function block can be seen added to the list. Press <Escape> again to return to the top level menu.

Note. Any function block copied while the control strategy is running, on-line, are made as 'Tentative'. They will not become part of the running control strategy until either 'TRY' or 'APPLY' is selected from the Utilities menu.

C.3.3 DELETE command

Deletes function blocks from the control strategy.

Note. Before deleting a function block all connections to and from it must be cleared. This is achieved simply by clearing the source fields of each affected connection, including the source fields of any input connection.

Select DELETE from the main menu to display all the function blocks in the control strategy, in the same format as for the COPY option, see [Copy command section](#). Select a function block and press <Enter>. The function block and any connections *from it* are deleted, and the main menu returns to the screen.

Note. Any function blocks deleted while the control strategy is running (online), are marked as 'DeleteReq'. They will not be removed from the control strategy until either 'TRY' or 'APPLY' is selected from the Utilities menu.

C.3.4 INSPECT command

Allows function blocks in the control strategy to be inspected and updated. Select INSPECT from the main menu to display all the function blocks in the control strategy, in the same format as for the COPY and DELETE options already described. Select a function block and press <Enter> to display its overview page, ready for monitoring/updating.

Pressing <Escape> returns the INSPECT display, where other function blocks can be selected for inspection. Press <Escape> again to return to the top level menu.

Note. All function blocks can be inspected while the control strategy is running, online.

C.3.5 NETWORK command

Allows a LIN database to be assigned to a specific LIN node address. This permits locally generated function blocks to be configured as ‘cached’ function blocks by changing the *DBase* field in the function block Title bar, see *Make* command. (The overview page of the cached function block *DBase* field specifies the remote LIN Database name.)

Note. It is good practice when using cached function blocks, to cache at least one block in each direction. This allows the status of the communications link between the nodes to be monitored from both ends via the cached blocks’ software alarms. This ‘bidirectional caching’ also eliminates the fleeting software alarms that may otherwise be seen during changeover in a redundant mode system.

Select NETWORK from the main menu to display the *Network setup* page (initially blank). Figure C.3.5 shows the top part of an example page with several LIN Databases already assigned.

Network setup	
Alpha	> 01
Beta	> 02
dBase_1	> 03

Figure C.3.5 Network setup page (example)

To assign a new LIN Database name and address, locate the underline cursor at the left hand column of a blank row, type in a unique name (7 characters max.) and press <Enter>. The name appears added to the list together with a default node address >00. Move the cursor to the default address and type in the required node address (two hex digits). Press <Enter> to assign the LIN Database to the specified node address.

Note. Non-unique or invalid names are ‘beeped’ and not accepted. Do not use 00 or FF as node addresses.

To edit an existing name or address, locate the cursor at a field, type in the new value, and press <Enter>. Invalid entries are not accepted.

To delete a complete name and address entry, edit its name field to a *space* character. Configurations downloaded from LINtools will have a Network page set up automatically.

Note. External Databases (EDBs) cannot be created while the control strategy is running, online.

C.3.6 UTILITIES command

Allows program control, I/O calibration, and filing. Select UTILITIES from the main menu to display the Utilities Options page, shown in Figure C.3.6.

UTILITIES	Select option
>START	- Start runtime system
STOP	- Stop runtime system
SAVE	- Save database
LOAD	- Load database
FILE	- File page
TRY	- Try Changes
UNTRY	- Untry Changes
APPLY	- Apply Changes
UNDO	- Undo Changes
ELIN	- Elin Setup

Figure C.3.6 UTILITIES options menu

START, STOP COMMAND

Select START or STOP from the UTILITIES options menu and press <Enter> to start or stop the control program running in the instrument. If the control strategy program is in progress, ‘Running’ appears below the first line in the Configurator, but will change to ‘Stopped’ if the control strategy is halted.

Note. When you START a LIN Database in RAM it is automatically saved to the file in E: drive called filename.dbf, where filename is indicated in the filename.RUN file. It is then reloaded and started.

SAVE COMMAND

Saves and saves a control program to a specified memory area. Select SAVE from the UTILITIES options menu - the default filename specification, **E:<filename>.DBF** is displayed. (The prefix **E:** directs the save to the local E: drive area of the instrument; this is the only available memory area. To save a database to a remote instrument, prefix the filename specification by the node address of the instrument separated by a double colon, e.g. **FC::E:<filename>.DBF**).

Type in a new specification if needed, then press <Enter> to execute the save. After a short pause the T280 instrument signals completion with the message: ‘**Type a key to continue**’. Typing any key returns the UTILITIES menu.

An invalid filename specification aborts the save, and an error message is sent, e.g. ‘**Save failed - Invalid device**’.

Notes.

- 1. When you START a LIN Database in RAM it is automatically saved to the file in E: drive called filename.dbf, where filename is indicated in the filename.RUN file. It is then reloaded and started.*
- 2. Modifications to a LIN Database are carried out on the RAM image only, not directly to the filename.dbf file in E: drive. They are copied to E: drive (overwriting the existing filename.dbf file) automatically as you restart the LIN Database, or when you do a SAVE operation.*

C.3.6 UTILITIES command (Cont.)

LOAD COMMAND

Retrieves a control program from a specified memory area and loads it to the instrument RAM.

Note. A LOAD operation can be performed using the 'Load' option during online reconfiguration.

Select LOAD from the UTILITIES options menu - the default filename specification, **E:<filename>.DBF** is displayed. Edit the specification if needed (to alter the filename or its source, as described in 'SAVE utility' above), then press <Enter>. After a short pause the instrument signals completion as described for the SAVE option. Typing any key returns the UTILITIES menu.

An invalid filename specification aborts the load, and an error message is sent, e.g. **'Load failed - File not found'**.

FILE COMMAND

Permits access to the instrument file page, allowing files to be deleted or copied, and the E: device to be formatted. The file page displays files in the E-device and also in a configurable remote **??::?:** device. To access a remote device, move the cursor to the **??::?:** field and type in the required node and device letter, e.g. **FA::M:**. Press <Enter> to display its files (up to a maximum of 20). Press <Escape> to return to the UTILITIES menu.

Move the cursor up and down the file list and tag files with an asterisk (*) using <Enter>. Then move the cursor to the top column-head field and press <Enter> to display the function menu: *Copy, Delete, Find*, and - for E-device only - *Format*. Finally, select a function and press <Enter> to carry it out.

Note. The Find function has wild-card characters (?) to help you locate filenames containing known character strings).

TRY/UNTRY CHANGES COMMAND

LIN Database changes can be Tried and Untried on a running LIN Database from the Configurator. If the control strategy has 'Tentative' changes, 'Changes' appears below the first line in the Configurator, but will change to 'Trying' when testing the strategy. Any such changes made whilst the LIN Database is running are 'Tentative', as indicated on the Configurator screen and are not applied until APPLY is selected. These 'Tentative' changes can be discarded by selecting UNTRY, before APPLY has been selected. UNTRY has no effect once APPLY has been used.

Note. If changes have been applied, and a synchronisation is attempted, it will fail unless the LIN Database running in the primary instrument has been saved using either the root LIN function block's full save option, or it is stopped, saved and started from the Configurator program.

Select TRY or UNTRY from the UTILITIES options menu and press <Enter> to try or untry the 'Tentative' changes to the control strategy running in the instrument.

APPLY/UNDO COMMAND

LIN Database changes can be executed online from the Configurator. Any such changes made whilst the LIN Database is running are 'Tentative' and are not applied until APPLY is selected. These 'Tentative' changes can be discarded by selecting UNDO, before APPLY has been selected. UNDO has no effect once APPLY has been used.

Note. If changes have been applied, and a synchronisation is attempted, it will fail unless the LIN Database running in the primary instrument has been saved using either the root function block's full save option, or it is stopped, saved and started from the Configurator program.

C.3.6 UTILITIES command (Cont.)

ELIN SETUP PAGE COMMAND

The *ELIN Setup* page allows the instrument's 'network.unh' file to be configured.

Note. The Network configuration can be edited using the Instrument Properties dialog via the Project Environment or the instrument folder. The 'network.unh' file can also be edited using an appropriate text editor, e.g. 'notepad.exe'.

```

Elin Setup (network.unh file)
-----
LIN PROTOCOL SETUP
Protocol Name      RKN
All Subnet Enable OFF
Elin Only Enable  ON

LOCAL IP SETUP
Get Address Method Fixed
IP Address         149.121.128.209
Subnet            255.255.252.0
Default Gateway   149.121.128.138

REMOTE SUBNET NODE LIST
149.121.173.1

TELNET
Login Id
Password          *****
    
```

Figure C.3.6 ELIN Setup page (example)

LIN PROTOCOL SETUP This area of the screen allows specification of the items in the '[LIN]' section of the 'network.unh' file.

LOCAL IP SETUP Allows the specification of those items in the '[IP]' section of the 'network.unh' file. The IP address etc. is entered using data obtained from the network administrator.

REMOTE SUBNET NODE LIST Allows the user to enter the IP addresses of all the nodes with which it is required to communicate. (The '[PR]' section of the 'network.unh' file.)

Once all the required entries have been made, the ESC key should be operated. A confirmation message asks if the 'network.unh' file is to be updated. If 'Y', the file is updated and a power cycle is requested.

CROSS SUBNET WORKING With 'All Subnet Enable' set 'OFF' (default), the instrument will not communicate ELIN cross subnet. This can be overridden in the network.unh file by setting 'All Subnet Enable' to 'ON'. This defines the behavior when the instrument is powered on. The ability to communicate cross subnet can be modified at run time by using the 'Options.AllSubnt' bit in the instrument's header block. Set to TRUE, this bit enables cross-subnet working. When set to FALSE, cross-subnet working is disabled.

Note. This bit may be set FALSE, remotely, from a cross-subnet connection. If this is done, communications will be lost, and it will thus not be possible to reset it to TRUE from the cross-subnet connection.

C.3.7 ALARMS command

Select ALARMS to view the currently active alarms in the instrument. Move the cursor up and down the list; press <Enter> to acknowledge an individual alarm. Press I to inspect the LIN function block containing the alarm.

C.4 MODBUS CONFIGURATION

Most Modbus configuration is completed before despatch, using the Modbus configuration tool. However, this basic Terminal Configurator is resident within the instrument and permits both offline configuration and online reconfiguration.

Following the successful start of a 'Telnet' session, and access from the Initial Menu, the Gateway Modbus Configuration menu appears, see [Figure C.4](#).

```
GATEWAY  MODBUS  Configuration
-----
>GWindex  - Select GW index
MODE      - Operating mode
INTERFACE - Select interface
SETUP     - Configure interface
TABLES    - Register and bit configuration
```

Figure C.4 Modbus Configurator Main menu

C.4.1 GWindex command

This command only appears in products that support multiple GW indices, see [Figure C.4.1](#).

Select the GWindex number to be viewed by the Configurator. This is limited from 1 to the maximum number of GW indices supported by the instrument, e.g. 3 for the T2550. The filename from where the GW index number was loaded appears in the Filename field.

```
GWindex Select GWindex
-----
GWindex  1
Filename  ABCDEFGH
```

Figure C.4.1 GWindex menu

C.4.2 MODE command

Sets the operating state of the instrument to *Modbus Slave* or *Modbus Master*.

```
MODE  Operating mode
-----
Mode  > Slave
      Master
```

Figure C.4.2 OPERATING MODE menu

C.4.3 INTERFACE command

Sets the Interface Type and Interface Instance of the instrument via enumerated lists, see [Figure C.4.3](#).

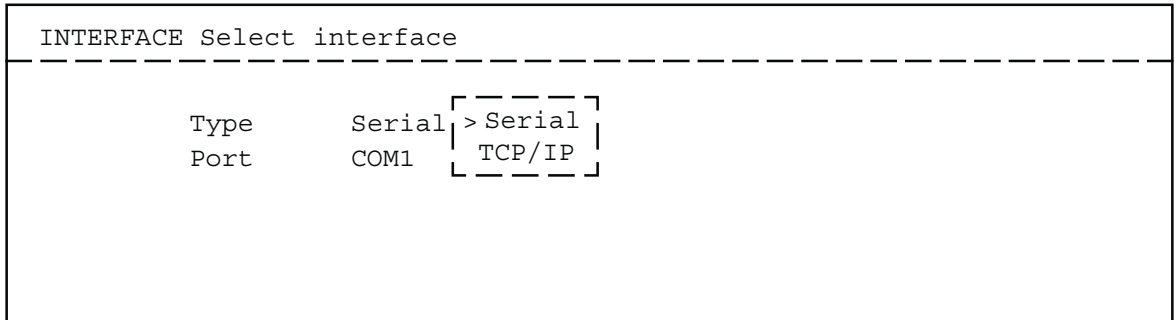

Figure C.4.3 INTERFACE menu

Select the Interface Type, Serial or TCP/IP, used to communicate with the Modbus instrument and then define the Port it is connected to.

Note. Individual Modbus specifications are described in the appropriate instrument handbook.

C.4.4 SETUP command

Configures the selected Interface Type and Interface Instance of the instrument defined in the INTERFACE menu. Selecting SETUP displays a menu that is dependant on the INTERFACE and MODE configurations.

- Serial master

If the Serial is selected in the INTERFACE menu and Master is specified in the MODE menu this SETUP menu will show the Baud rate, Parity, Stop bits, and Time out fields.

- Serial slave

If the Serial is selected in the INTERFACE menu and Slave is specified in the MODE menu this SETUP menu will show the Baud rate, Parity, Stop bits, Time out, and Slave No. fields.

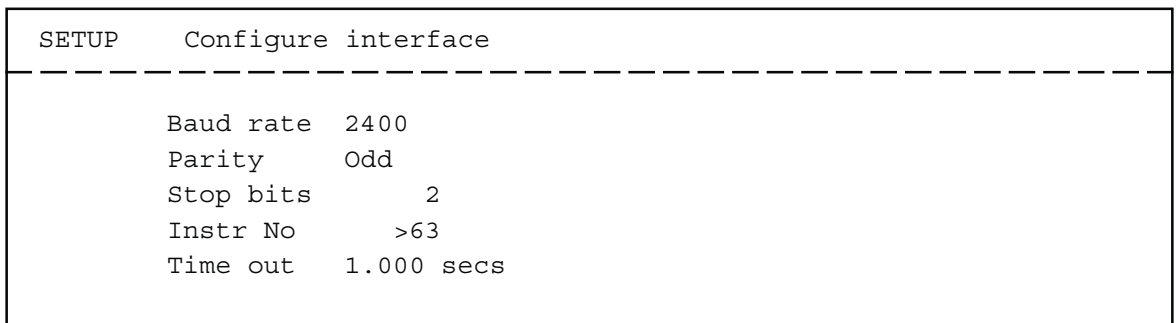

Figure C.4.4 Typical TCP/IP Slave SETUP menu

- TCP master

If the TCP/IP is selected in the INTERFACE menu and Master is specified in the MODE menu this SETUP menu will show the Time out field only.

- TCP slave

If the TCP/IP is selected in the INTERFACE menu and Slave is specified in the MODE menu this SETUP menu will show the Port no, Instr No, Time out, and CNOMO fields.

Note. If the instrument supports CNOMO registers, this field indicates that Register Offset values 121, to 124 will display specific Manufacturer and Product details.

C.4.4 SETUP command (Cont.)

This page gives general information about the Interface configuration.

Port no	TCP/IP Interface and Slave Operating Mode only. It shows the TCP port via which this modbus-TCP-slave instance communicates. 0 = default = 502.
Baud rate	Highlight and enter this item to see a menu of the available baud rates, 110, 150, 300, 600, 1200, 2400, 4800, 9600, and 19200. Select and enter the required baud rate.
Parity	Entering this item displays a menu of options, None, Odd, and Even. Select and enter the required parity.
Stop bits	Enter this item, type in the required number of stop bits, and press <Enter> to update the SETUP menu, <i>Only 1 or 2 stop bits are permitted.</i>
Line type	Shown only if both Serial Interface is selected and instruments supports software selection of 3-wire/5-wire operation.

Note. This is not currently supported.

Time out	Enter a <i>Time out</i> value, in the range 0 to 65.5 seconds. In slave mode, this parameter specifies a watchdog period for all tables. That is, if a table has not been accessed for <i>Time out</i> seconds, the <i>Online</i> bit in the slave mode diagnostic register for that particular table resets to zero. In master mode, <i>Time out</i> specifies a maximum period between the end of a master's request for data to the start of the slave's response. If this time is exceeded, the <i>Online</i> bit in the master mode diagnostic register for the particular table concerned resets to zero.
Instr No	Slave Operating Mode only. Input an 'instrument number', i.e. the address on the Modbus Serial link of the slave device being configured. Slave addresses are in the range 01 to FF hexadecimal, but note that for some equipment FF is invalid.

C.4.5 TABLES command

Shows the Tables List dependant on the MODE configuration. To view the tables list, highlight TABLES and press <Enter>. Individual menus can be displayed by selecting the required Table number, see Table Menus.

TABLES LIST

The Tables List provides an overview of all the tables in the Modbus configuration. Each instrument will support a maximum number of Tables as defined by the MAX_TABLES field in the instrument Configuration (Header) block. The Tables List offers sixteen tables per page, therefore an instrument supporting 64 Tables, e.g. T2550, will cover 4 pages.

This menu allows tables to be created and the types, offsets, sizes, and for master mode, function codes, scan counts, instrument numbers and tick rate to be specified. The Tables List also accesses individual Table Menus for detailed configuration, i.e. LIN Database mapping, see [Table Menu section](#).

The Tables List menu below, [Figure C.4.5a](#), shows an example Tables List with Table 1 configured as a Register Table. The first four columns, Table, Type, Offset, and Count, are common to both the Master and Slave Operating Modes. The remaining, Functions, Scan count, Instr No, and TickRate appear only when Master Operating Mode is configured.

Table	Type	Offset	Count	Functions	Scan count	Instr No	TickRate
1	Register	0	16	3 4 6 16	16	>00	100
2	Unused	0	0	- - - -	0	>00	0
3	Unused	0	0	- - - -	0	>00	0
4	Unused	0	0	- - - -	0	>00	0
5	Unused	0	0	- - - -	0	>00	0
6	Unused	0	0	- - - -	0	>00	0
7	Unused	0	0	- - - -	0	>00	0
8	Unused	0	0	- - - -	0	>00	0
9	Unused	0	0	- - - -	0	>00	0
10	Unused	0	0	- - - -	0	>00	0
11	Unused	0	0	- - - -	0	>00	0
12	Unused	0	0	- - - -	0	>00	0
13	Unused	0	0	- - - -	0	>00	0
14	Unused	0	0	- - - -	0	>00	0
15	Unused	0	0	- - - -	0	>00	0
16	Unused	0	0	- - - -	0	>00	0

Figure C.4.5a Typical Master Mode Table menu

C.4.5 TABLES command (Cont.)

This page gives general information about the Modbus Table configuration.

Table	This is the Table number, which is not editable. Highlight and <Enter> a Table number field to display the information related to the selected Table number. For a table with a Type other than Unused, the table menu for that table is displayed, see Table Menu.
Type	This field, defaults to Unused, allows the Table Type to be created or edited. Enter a Type field to see a menu of four options. Select one and press <Enter> to create a new table or convert an existing one to a new type.

Note. Other fields in the Tables List associated with the selection automatically adopt default values.

The Type options are:

- Unused The table does not exist.
- Register This type of table maps LIN Database parameters to standard 16-bit Modbus registers.
- Digital This type of table maps LIN digital, boolean or alarm values to bits in the Modbus address space.
- Diagnostic This is a special table, similar to a Register Table, but the values in the table have pre-defined values that are used to control the Modbus operation, or present diagnostic information to the LIN Database.

Offset	This field selects the start address of the table on the Modbus network. These values are the actual values used in the address field of the Modbus messages, i.e. the 'protocol addresses'.
--------	--

Note. PLCs differ in the correspondence between their register or bit addresses and the protocol addresses.

Count	This field shows the number of registers or bits in a table. It allows the size of register and digital tables to be changed from their default values of 64 registers or bits, respectively, to optimise the use of memory. Diagnostic tables are fixed at 32 registers.
Functions	<p>Master mode only. This field allows the default Modbus function codes that can be used with a particular Modbus table type to be enabled or disabled. Modbus function codes define the type of data exchange permitted between Master and Slave instruments via a particular table.</p> <p>To disable a default function code, highlight it with the mouse and press <Enter> to see a menu of '-' and the default code number. Selecting and entering '-' disables that code for the table concerned. Select the code number again to re-enable it if required.</p>
Scan count	Master mode only. This sets the maximum number of registers (register table) or bits (digital table) that can be read or written in a single Modbus transmission. Scan count defaults to the same value as Count, i.e. as the table size, which results in the whole table being updated each polling cycle. If Scan count is made less than Count for a particular table, it takes more than one cycle to be updated but the overall polling cycle speeds up. This may be required for Modbus devices with limited buffer sizes.
Instr No	Master mode only. This specifies the hexadecimal Slave number value of the instrument on the Modbus network in which the data registers or bits associated with this master table are located.
Tick Rate	Each table of registers is assigned a Tick Rate, a value between 0 and 65535 ms, to define the frequency at which it is scanned. The Tick Rate associated with each table can be configured. If the LIN instrument does not support Tick Rates, and/or if the instrument is configured to operate in Slave mode, the Tick Rate fields are disabled.

C.4.5 TABLES command (Cont.)

TABLE MENUS

You access an individual table menu from the tables list by highlighting its table number (in the first column headed *Table*) and pressing <Enter>. To highlight fields you can move the arrow cursor around a table menu using the mouse, or the PC's <Home>, <End>, and cursor keys.

Table menus allow the mapping between the LIN Database fields and the Modbus addresses to be configured.

The Table Menu below, **Figure C.4.5b**, shows an example of the default Table Menu for a Register (or Diagnostic) Table.

Note. Table headings differ between Register and Digital Tables, but some fields are common to both, e.g. Field, DB Write, and MOD Write.

Register	Field	DP	Format	DB Write	MOD Write	Value
0		0	Normal	Enable	Enable	>0000
1		0	Normal	Enable	Enable	>0000
2		0	Normal	Enable	Enable	>0000
3		0	Normal	Enable	Enable	>0000
4		0	Normal	Enable	Enable	>0000
5		0	Normal	Enable	Enable	>0000
6		0	Normal	Enable	Enable	>0000
7		0	Normal	Enable	Enable	>0000
8		0	Normal	Enable	Enable	>0000
9		0	Normal	Enable	Enable	>0000
10		0	Normal	Enable	Enable	>0000
11		0	Normal	Enable	Enable	>0000
12		0	Normal	Enable	Enable	>0000
13		0	Normal	Enable	Enable	>0000
14		0	Normal	Enable	Enable	>0000
15		0	Normal	Enable	Enable	>0000

Figure C.4.5b Typical Master Mode Table menu

This page gives detailed information about the selected table configuration.

Register Register and diagnostic tables only. This column shows the Modbus address of the particular register. The first register in the table takes its address from the Offset value given to the table via the Table List. The remaining (read-only) addresses follow on consecutively.

Digital Digital tables only. This column shows the Modbus address of the digital bit on the selected line of the table. If the line contains a bitfield rather than a single bit, the address shown is that of the first bit in the bitfield. Mappings may be made for a single bit, or for an 8- or 16-bit field, according to the value defined in the *Width* parameter. The first bit address in the table takes its value from the *Offset* given to the table via the Table List. The remaining (read-only) addresses follow on according to the numbers of bits on each successive line of the table (1, 8, or 16).

C.4.5 TABLES command (Cont.)

Field This is the LIN Database field that the Modbus address is mapped to. It can remain blank. Select a field with the cursor and type in and enter a LIN function block name plus parameter (and subfield if needed), separated by periods, e.g. **PV1.Alarms.Software**.

Note. If attempting to enter an analogue parameter into a digital table Field, the entry is ignored. However any type of parameter can be entered in a register (or diagnostic) table. If attempting to enter or overwrite a LINDatabase parameter that would force an entry lower down the table to change its address (Digital value), the edit is ignored.

DP Register and diagnostic tables only. This column can be used for either of two functions: specifying a decimal point position, or creating a 32-bit register.

Decimal point position DP can store a decimal point scaling factor that is used when converting floating point numbers to 16-bit Modbus registers. For this purpose, enter an integer from 0 to 4; the *DP* -value represents the number of decimal places in the converted number.

32-bit register Register tables only. A 32-bit register is created by ‘joining’ a consecutive pair of 16-bit registers. The restrictions that are applied to ensure that the 32-bit value created is transferred indivisibly:

1. The multiread function (3) and multiwrite function (16) must both be enabled.
2. The scan count must be even.
3. The first register of the pair must be at an even offset within the table.
4. The first register of the pair must not be the last register in the table.
5. The second register of the pair must not already be assigned to a LIN Database field.
6. The field type of the 32-bit register pair must be 32-bit long signed or unsigned, 32-bit real or a string. For a string, only the first four characters are transferred.

To create a 32-bit register pair, enter ‘d’ (or ‘D’) in the *DP* field of the first register of the pair. This causes the register’s *DP* to adopt the value ‘D’, and the following register the value ‘d’. To create a reverse 32-bit register pair, enter ‘s’ (or ‘S’) in the *DP* field of the first register of the pair. If any of the above restrictions are violated, your entry will be rejected.

When the first register of the 32-bit pair is assigned to a LIN Database field, the second register automatically copies the same field name; assigning the name and the *DP* can be done in either order. To restore a 32-bit register pair to individual 16-bit registers change the first register’s *DP* to 0-4.

C.4.5 TABLES command (Cont.)

Format Register and diagnostic tables only. This column specifies the format of the data in the register, normal or BCD (binary coded decimal). Normal format means that the data is a simple 16-bit integer. In BCD format the value is first limited to the range 0-9999, and then stored as four 4-bit nibbles in the register. The units are stored in the low order nibble, the tens in the second nibble, the hundreds in the third, and the thousands in the high-order nibble. BCD format allows the data to be used with certain devices such as displays.

Note. Format is ignored in 32-bit registers.

Width Digital tables only. This column indicates the number of bits contained in the associated field. The default *Width* is 16, but it automatically updates when you allocate a parameter to the field. Allocated field ‘widths’ are read-only, but you can specify the width of an unallocated field by highlighting its *Width* value and entering a valid number, in the range 1 to 16, but normally only 1, 8, or 16.

Note. Editing a Width value is not permitted if this would force an entry lower down the table to change its address (Digital value).

DB Write This column prevents the selected values in the LIN Database from being overwritten by values received across the serial link. Highlight the required *DB Write* field and press <Enter> to see a menu of options, Enable and Protect. Select *Protect* to write-protect the LIN Database parameter, or *Enable* to allow overwriting.

Note. For a 32-bit register pair, DB Write applies only to the first register. The DB Write -value of the second register is ignored.

MOD Write This column prevents the selected values in the LIN Database from being written to their associated Modbus registers or bits. Highlight the required *MOD Write* field and press <Enter> to see a menu of options, Enable and Protect. Select *Protect* to write-protect the Modbus register/bit(s), or *Enable* to allow overwriting.

Note. The easiest way to globally protect an entire table, in a Modbus Gateway facility operating in Modbus Master mode, is to disable its write function codes (5 and 15, or 6 and 16) in the Tables List. For a 32-bit register pair, MOD Write applies only to the first register. The MOD Write -value of the second register is ignored.

Value This column shows the current 16-bit value of the field in 4-digit hexadecimal representation. ‘Value’ is read-only.

Intentionally left blank

APPENDIX D I/O MODULES

This chapter presents safety and EMC information and describes the mechanical and electrical installation of the instrument. The main topics covered are as follows:

- Introduction ([section D.1](#))
- Isolator links and Fuses (optional for I/O Terminal Units Only) ([section D.2](#))

D.1 INTRODUCTION

The Base Unit is fitted with the I/O Controller Module(s) plus additional I/O Modules. These modules plug onto Terminal Units, see *Installation*, which provide the wiring interface between the plant or machine and the I/O modules. Each 16-way Base Unit uses approximately 1,800mA power consumption. Intercommunication between the I/O modules is effected by the use of the internal module I/O bus. The signals on this bus are transferred between modules through a series of connectors mounted on a printed circuit board running the full width of the base.

The following table shows a list of compatible I/O modules.

Type	Description	Slow I/O Task (110ms)	Fast I/O Task (10ms)
AI2	Analogue I/P 2 channels (universal; 3 Terminal Unit options)	✓	-
AI3	Analogue I/P 3 channels (4-20mA, with transmitter PSU)	✓	-
AI4	Analogue I/P 4 channels (TC, mV, mA Terminal Unit options)	✓	-
AO2	Analogue O/P 2 channels (0-20mA or 0-10V output)	✓	-
DI4	Digital I/P 4 channels (logic)	✓	-
DI8_LG*	Digital I/P 8 channels (logic)	✓	✓
DI8_CO*	Digital I/P 8 channels (contact closure)	✓	✓
DI6_MV	Digital I/P 6 channels (ac mains input, 115V rms)	✓	-
DI6_HV	Digital I/P 6 channels (ac mains input, 230V rms)	✓	-
DO4_LG*	Digital O/P 4 channels (externally powered, 10mA)	✓	✓
DO4_24*	Digital O/P 4 channels (externally powered, 100mA)	✓	✓
DO8	Digital O/P 8 channels	✓	✓
RLY4*	Relay O/P 4 channels (2 amp; 3 n/o, 1 change-over)	✓	✓
FI2	Frequency I/P 2 channels (logic, magnetic, and contact closure)	✓	✓
ZI	Zirconia Probe I/P 2 channels (mV (TC), high impedance 0-2V)	✓	-

*Note. * indicates the Module upgraded, refers to Version 2 modules.*

D.2 ISOLATOR LINKS AND FUSES (OPTIONAL FOR I/O TERMINAL UNITS ONLY)

Up to four isolator links or fuses are available as options for certain modules.

Isolator links disconnect plant connections from the module (for testing and commissioning).

The fuses supplied for the relay units are 4A (T type), 20mm to EN60127. Fuses of a lower rating may be fitted to suit the application.

The label on the side of the fuse holder may be used to indicate the correct type of fuse. The label on the top of the fuse holder may be used to identify or tag the protected circuit.

If isolator links or fuses are not fitted then a dummy fuse cover must be fitted.

Intentionally left blank

APPENDIX D1 2500P - 24V POWER SUPPLY

D1.1 DESCRIPTION

The 2500P is a fully protected stabilised power supply unit which provides 24V DC to power the T2550 or 2500 DIN rail controller, from a mains supply of 115 or 230V AC, 47 - 63 Hz. The maximum power rating of a T2550 or 2500 DIN rail controller is 90W, but the actual size depends upon the power rating of the modules in use. This can be calculated from the Module Power Consumptions.

Note The 2500P power supply can also be used to supply external plant devices if required.

The power supply is designed to mount directly on to a DIN rail either next to or separated from the T2550 or 2500 base, and the following versions are available:

- 2500P/1A3 rated at 24V, 1.3amp, 30 watt, input 35VA.
- 2500P/2A5 rated at 24V, 2.5amp, 60 watt, input 70VA.
- 2500P/5A0 rated at 24V, 5.0 amp, 120 watt, input 140VA
- 2500P/10A rated at 24V, 10 amp, 240watt, input 275VA

Additional power supplies can be wired in parallel if currents greater than that available from an individual supply are required or to provide power supply redundancy.

D1.2 MODULE IDENTIFICATION

The power supply module may be identified by means of labels on the side and front of the case. The side label includes details of the product code and serial number.

D1.3 CONFIGURATION

There is no configuration requirement for power supplies.

D1.4 LOCATION

This module should be located on the DIN rail, immediately to the left of the Base Unit.

D1.5 TERMINAL CONNECTIONS

Warning

Warning! Always isolate the power before disconnection.

Note The PSU 24V connections should not be connected to earth since this will bias communications at an elevated level. (A 10KW resistor is connected from RJ45 communications to earth which provides a bleed for static).

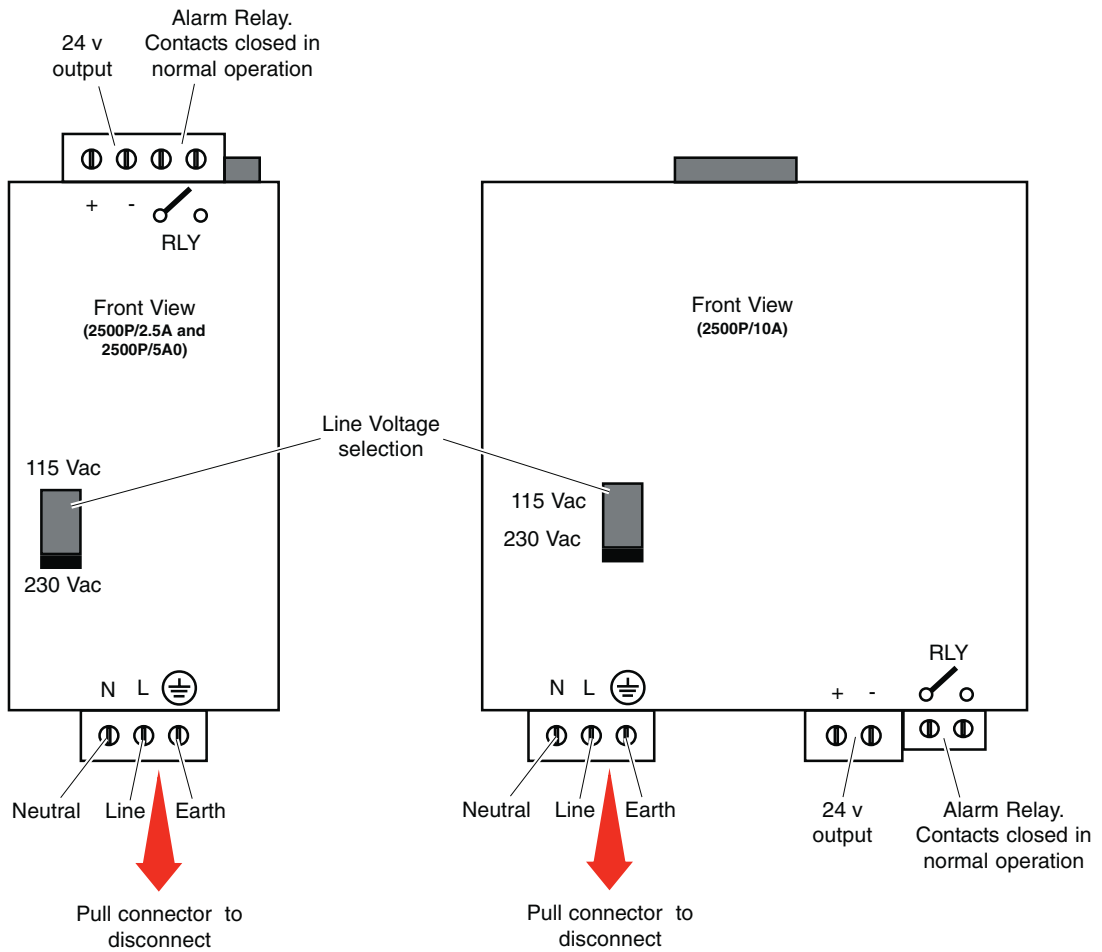

Figure 2500P-4 2500P Power Supply Terminal Connections

D1.6 STATUS INDICATION

The status of the module is shown by a single LED indicator as follows:

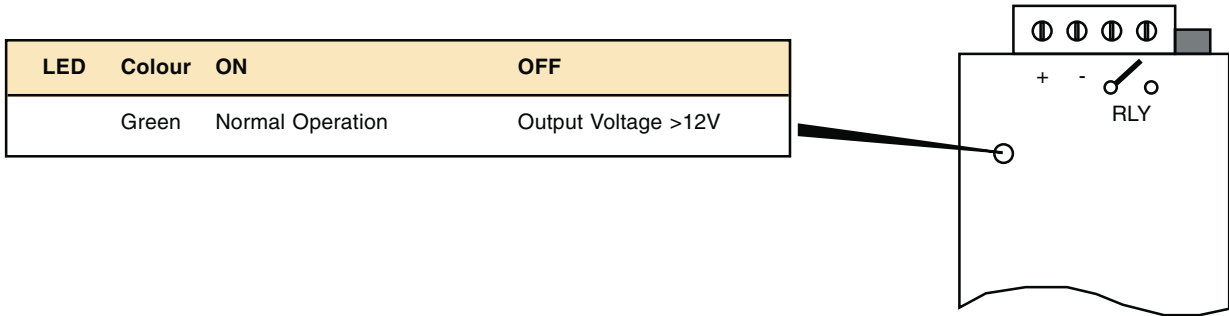

Figure 2500P-5 2500P Power Supply Status Indication

D1.7 SPECIFICATIONS

D1.7.1 2500P Module

Input Specification

Nominal Input Voltage Range: 110-120/220-240V, 47-63Hz, 85- 132Vac/176-264Vac.

Note Voltage selected by front panel switch. When located in the 230V position the Power Supply Unit operates at low and moderate loads at any input voltage between 95 and 275Vac (see Nominal Output Current).

Frequency:	47 to 63 Hz
Nominal Input Current:	2A5 - <1.3A (switch in 115V position), <0.7A (switch in 230V position) 5A0 - <2.6A (switch in 115V position), <1.4A (switch in 230V position) 10A - N/A
In-rush Current:	2A5 - <25A 5A0 - <15A 10A - <30A

Note 2A5 and 5A0 - 10A, B-type circuit breaker is the recommended input fusing.

Output Specification

Nominal Output Voltage:	24Vdc. $\pm 0.5\%$
Ripple (including spikes):	<30mV pp
Nominal Output Current:	2A5 - 2.5A (60W) 5A0 - 5A (120W) 10A - 10A (240W)
Voltage Regulation:	Better than 1% Vout overall
Parallel Operation:	Yes
Relay Contact:	1A, at 28Vdc

D1.8 MOUNT THE POWER SUPPLY

D1.8.1 DIN Rail Mounting

1. Tilt unit slightly backwards.

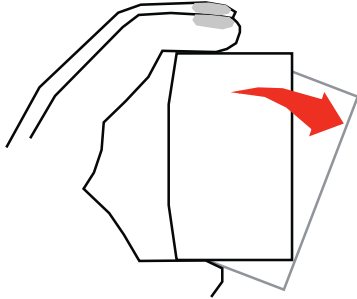

2. Put it onto the DIN rail.

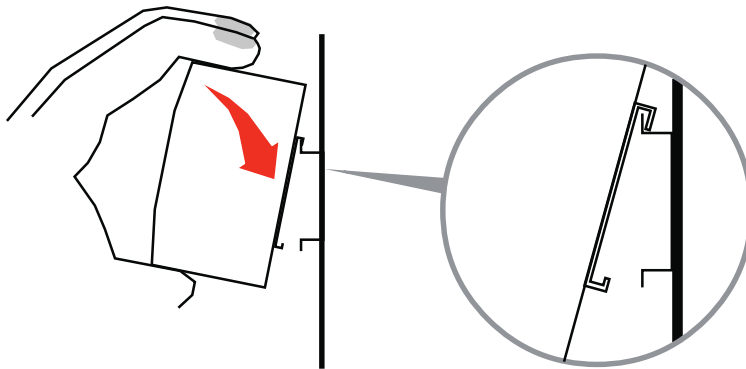

3. Push downwards until stopped, then push at the lower front edge to lock.

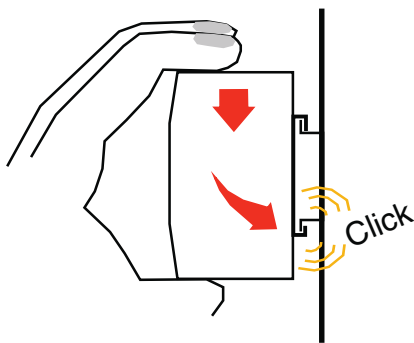

To detach from the DIN Rail:

Warning

Warning! Always isolate the power before disconnection.

1. Press the button on the top of the Power Supply Module downwards (to unlock) and carefully remove it from the DIN Rail.

Note The PSU 24V connections should not be connected to earth since this will bias communications at an elevated level. (A 10 KW resistor is connected from RJ45 communications to earth which provides a bleed for static).

Intentionally left blank

APPENDIX D2 AI2 - TWO CHANNEL ANALOGUE INPUT MODULE

D2.1 DESCRIPTION

The analogue input module is used to measure analogue signals from a range of plant sensors.

These include:

- Thermocouples
- Platinum Resistance Thermometers (2-, 3- and 4-Wire)
- Voltage +10V and +100mV
- High Impedance (Zirconia)
- Current +20mA.

The analogue input module consists of two input channels, isolated from each other and isolated from the system electronics. For thermocouple inputs Cold Junction Temperature is measured by a RTD sensor fitted to the Terminal Unit.

Typical parameters which can be configured or changed include:

- Input Type
- Range
- Input Filter Time Constant
- Sensor Break Action
- User Calibration. This allows you to offset the 'permanent' factory calibration to:
 - a. Calibrate the controller to your reference standards
 - b. Match the calibration of the controller to that of a particular transducer or sensor
 - c. Calibrate the controller to suit the characteristics of a particular installation

Note The Sensor Break Protection of the channel is controlled via an associated AI_UIO block.

D2.2 TERMINAL CONNECTIONS

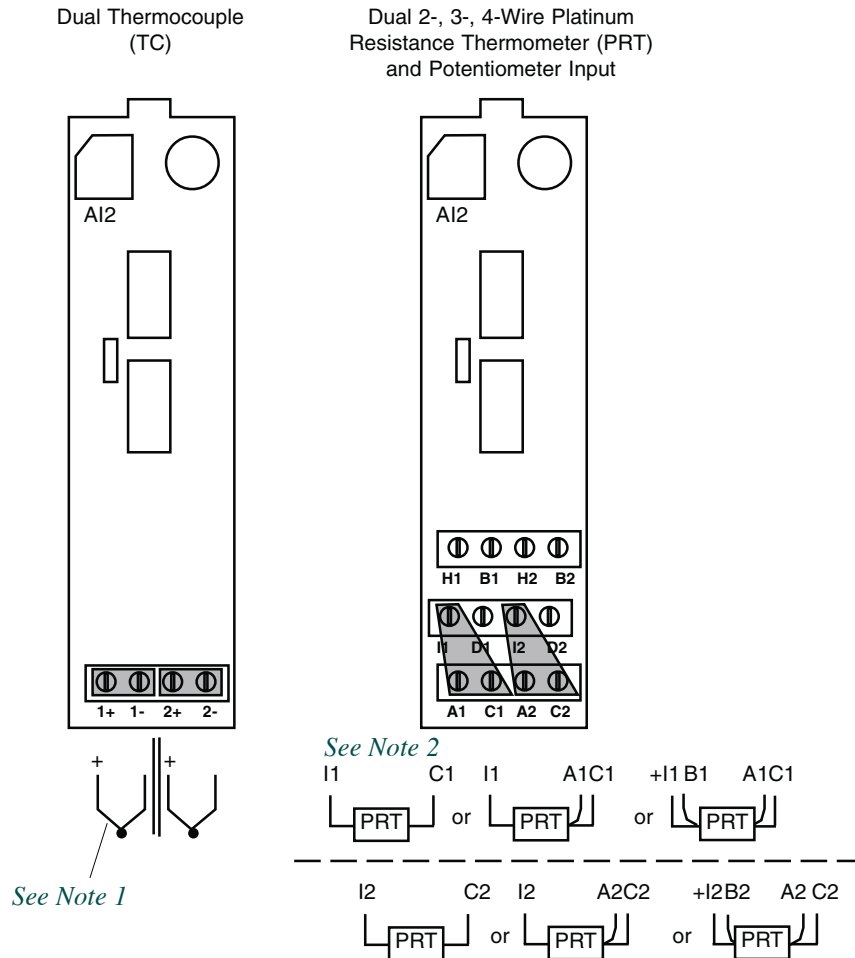

Notes.

- 1 If the AI module is configured as thermocouple input on one channel and +mV input on the other, then the thermocouple must be connected to Channel 1. Channel 2 can be used for the Zirconia probe milli-volt source if required.
- 2 Channel 1 - PRT 2-wire connection uses I1 and C1 only. Channel 2 - PRT 2-wire connection uses I2 and C2 only.

WIRING REDUNDANT MODULES

This module does support redundant wiring operation , see 2500M I/O Module Redundant Configuration Handbook.

Figure AI2-1a Two Channel Analogue Input Terminal Connections

D2.2 Terminal Connections (Cont.)

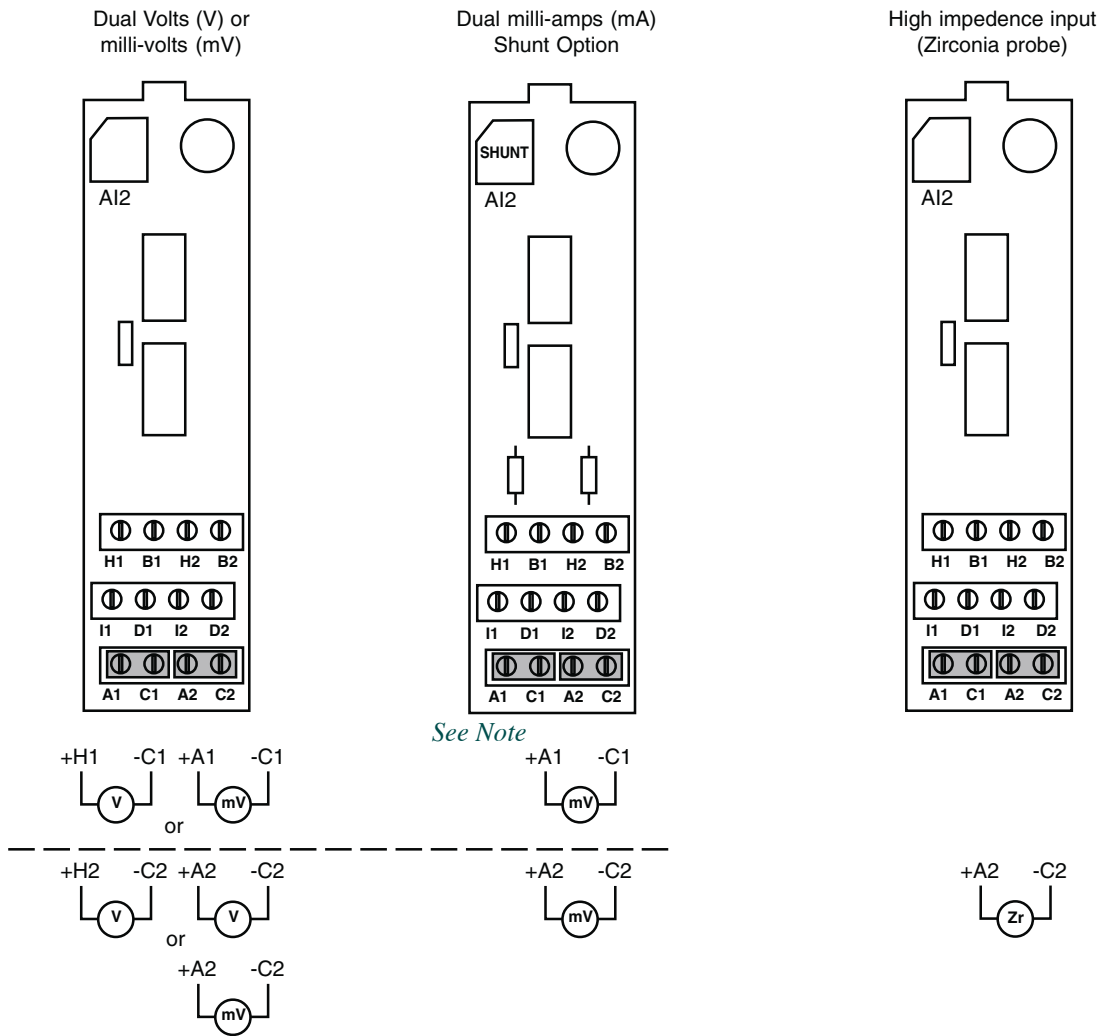

Channel	HR_in to LR_in Limits	Terminal Connections
CH1	-150mV to +150mV -10Vdc to +10Vdc	A1 and C1 C1 and H1
CH2	150mV to +150mV 0 to 1.8Vdc -10Vdc to +10Vdc	C2 and A2 C2 and A2 C2 and H2

Note. The Shunt option has 5Ω resistors mounted on the rear of the PCB.

Figure AI2-1b Two Channel Analogue Input Terminal Connections

D2.3 ANALOGUE INPUTS

D2.3.1 Isolation Diagram

Transducers can be directly wired into any appropriate channel at the terminals, but introduces safety implications, particularly risk of shock hazard. Electrical isolation minimizes such risks even when equipment goes faulty, and particularly when some transducers have to be run ‘live’.

To provide effective operation a very simple isolation strategy is implemented in the form of a barrier separating all I/O channels in any I/O module from the rest of the system. This prevents hazardous voltages on any I/O channel introducing hazards on any wiring on another I/O module, or put at risk the rest of the system. Modules providing isolation channel-to-channel ensure safety and good signal quality on all channels.

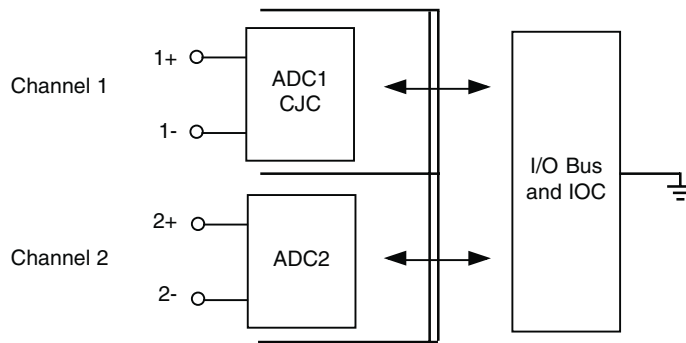

Figure AI2-2 Isolation Diagram

D2.3.2 Equivalent Circuits

The equivalent circuits below show details of analogue inputs, in particular sensor break circuits.

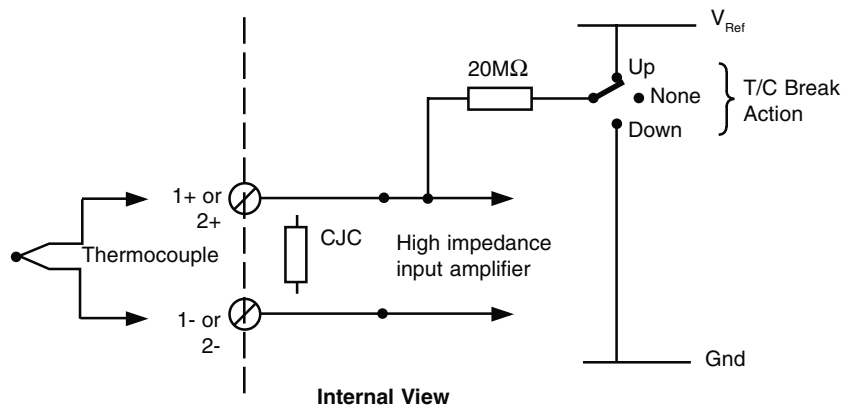

Figure AI2-3 Thermocouple Input

D2.3 ANALOGUE INPUT EQUIVALENT CIRCUITS (Cont.)

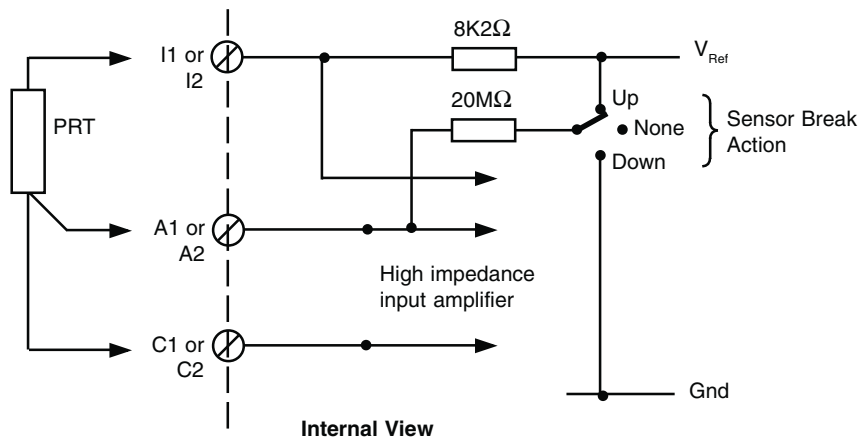

Figure AI2-4 3-Wire PRT Input

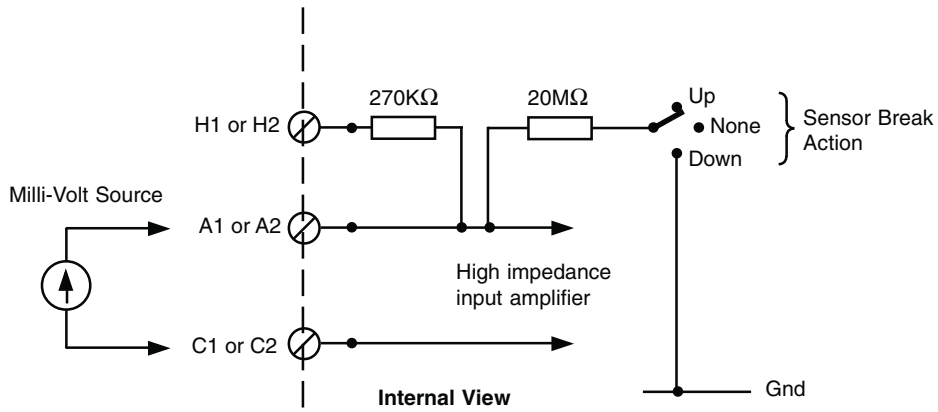

Figure AI2-5 mV Input

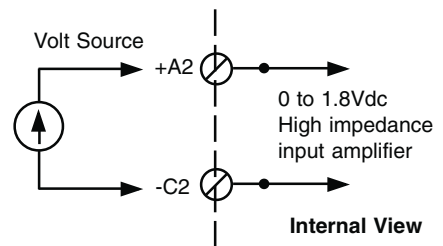
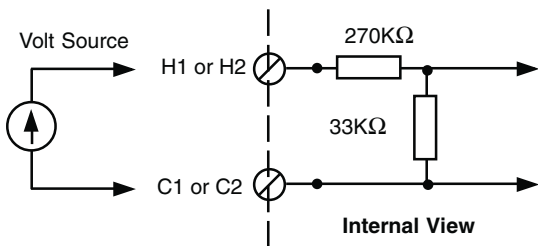

Figure AI2-6 Voltage Input

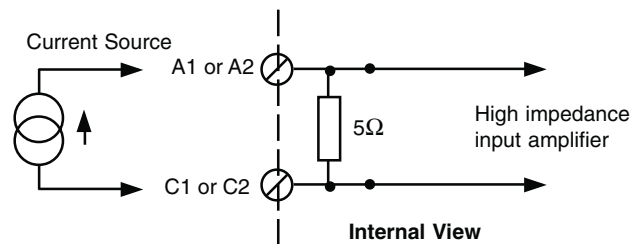

Figure AI2-7 mA Input

D2.4 STATUS INDICATION

The status of the module is shown by three LED indicators as follows:

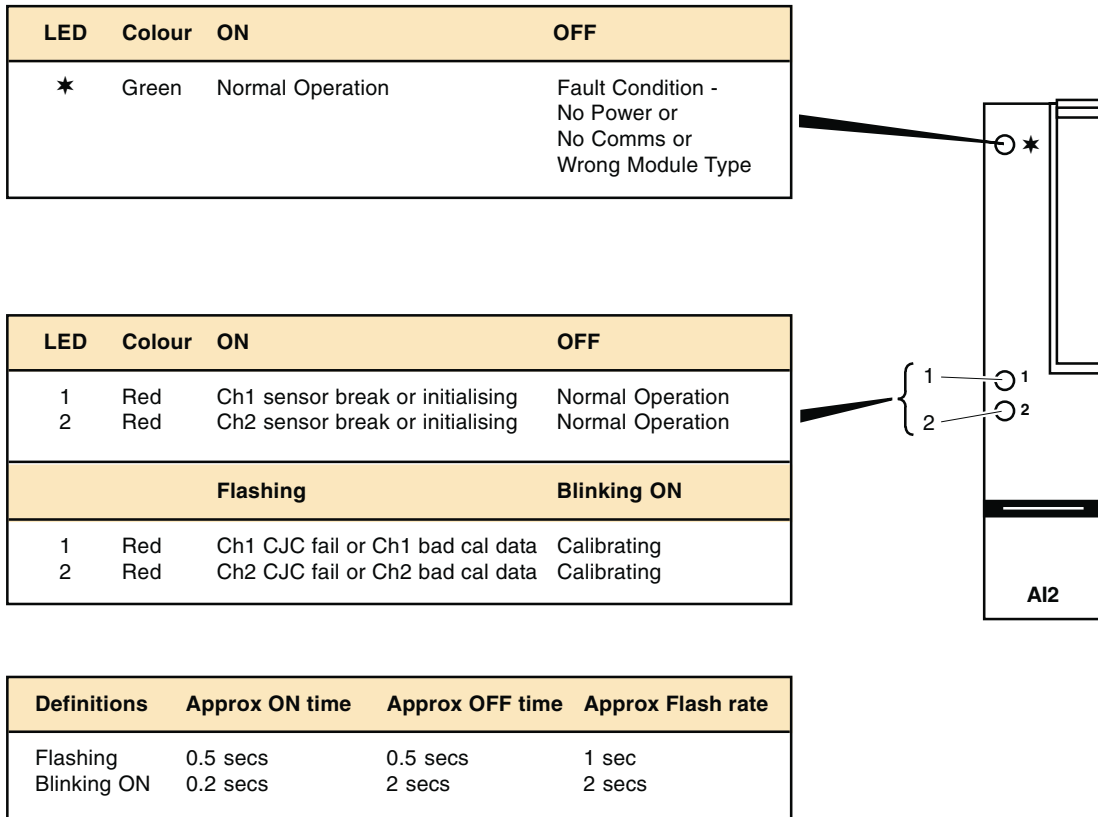

Figure AI2-8 Two Channel Analogue Input Status Indication

D2.5 SPECIFICATIONS

Values given with respect to V_s , where V_s is an externally supplied voltage, nominally 24V. Plant Side Interface.

D2.5.1 AI2 TC Module

Input Types: Analogue voltage, 150mV (TC) or 2V (Zirconia probe)

mV Input Specification

Input Range:	-150mV to +150mV.
Calibration Accuracy:	$\pm 0.1\%$ of 'MeasV' parameter reading, $\pm 10\mu\text{V}$.
Noise:	<4 μV p-p with 1.6s Filter, better with longer time constants. <28 μV p-p, filter off.
Resolution:	<2 μV with 1.6s Filter.
Linearity:	Better than 5 μV
Temperature Coefficient:	< 40ppm of reading per $^{\circ}\text{C}$
Sensor Break Protection:	Switchable, 125nA break low or break high (or off).
Input Impedance:	>100M Ω (break detect circuit disabled)
Input Leakage Current:	<100nA (break detect circuit disabled), 0.2nA typ.

HiZ Voltage Input Specification (Ch2 ONLY)

Input Range:	0.0V to +1.8V.
Calibration Accuracy:	$\pm 0.1\%$ of 'MeasV' parameter reading, $\pm 20\mu\text{V}$.
Noise:	<15 μV p-p with 1.6s Filter, better with longer time constants. <100 μV p-p, filter off.
Resolution:	<7 μV with 1.6s Filter.
Linearity:	Better than 50 μV
Temperature Coefficient:	< 40ppm of reading per $^{\circ}\text{C}$
Input Impedance:	>100 MW
Input Leakage Current:	<100nA, 1nA typ.

Cold Junction Sensor Specification

Temperature Range:	-10 $^{\circ}\text{C}$ to +70 $^{\circ}\text{C}$
CJ Rejection:	> 30:1
CJ Accuracy:	$\pm 0.5^{\circ}\text{C}$ ('Automatic' cold junction compensation)
Sensor Type:	Pt100 resistor, under the TU wiring terminals.

General Specifications

Module power consumption:	2W max.
Common mode rejection:	>120db, 47 - 63Hz
Series mode rejection:	>60db, 47 - 63Hz
Isolation channel - channel:	Functional (basic insulation), 264Vac max
Isolation to system:	Reinforced (double insulation), 264Vac max

D2.5.2 AI2 DC Module

Input Types: 150mV, 2V, 10V, 600 Ω , 6k Ω , and 5k Ω Pot inputs.

mV Input Specification

Input Range:	-150mV to +150mV.
Calibration Accuracy:	$\pm 0.1\%$ of 'MeasV' parameter reading, $\pm 10\mu\text{V}$.
Noise:	<4 μV p-p with 1.6s Filter, better with longer time constants. <28 μV p-p, filter off.
Resolution:	<2 μV with 1.6s Filter.
Linearity:	Better than 5 μV
Temperature Coefficient:	< 40ppm of reading per $^{\circ}\text{C}$
Sensor Break Protection:	Switchable, 125nA break low or break high (or off).
Input Impedance:	>100M Ω (break detect circuit disabled)
Input Leakage Current:	<100nA (break detect circuit disabled), 1nA typ.

HiZ Voltage Input Specification (Ch2 ONLY)

Input Range:	0.0V to +1.8V.
Calibration Accuracy:	$\pm 0.1\%$ of 'MeasV' parameter reading, $\pm 20\mu\text{V}$.
Noise:	<15 μV p-p with 1.6s Filter, better with longer time constants. <100 μV p-p, filter off.
Resolution:	<7 μV with 1.6s Filter.
Linearity:	Better than 50 μV
Temperature Coefficient:	< 40ppm of reading per $^{\circ}\text{C}$
Input Impedance:	>100 M Ω
Input Leakage Current:	<100nA, 1nA typ.

10 V Input Specification

Input Range:	-10.3V to +10.3V.
Calibration Accuracy:	$\pm 0.1\%$ of 'MeasV' parameter reading, $\pm 2\text{mV}$.
Noise:	<0.4mV p-p with 1.6s Filter, better with longer time constants. <2mV p-p, filter off.
Resolution:	<0.2 μV with 1.6s Filter.
Linearity:	Better than 0.7mV
Temperature Coefficient:	< 40ppm of reading per $^{\circ}\text{C}$
Input Impedance:	303K $\Omega \pm 1\%$

RTD and Ohms (3 and 4 wire) Input Specification

Input Range:	0 Ω to 420 Ω (RTD), 640 Ω (Range)
Calibration Accuracy:	$\pm 0.1\%$ of 'MeasV' parameter reading.
Noise:	<0.05 μV p-p with 1.6s Filter, better with longer time constants.
Resolution:	<0.2 μV with 1.6s Filter.
Linearity:	Better than 0.05 μV
Temperature Coefficient:	< 30ppm of reading per $^{\circ}\text{C}$

continued...

D2.5.2 AI2 DC Module (Cont.)**High Ohms Input Specification**

Calibration Accuracy:	$\pm 0.1\%$ of 'MeasV' parameter reading.
Noise:	$<0.05\mu\text{V}$ p-p with 1.6s Filter, better with longer time constants.
Resolution:	$<0.2\mu\text{V}$ with 1.6s Filter.
Linearity:	Better than $0.1\mu\text{V}$
Temperature Coefficient:	$< 30\text{ppm}$ of reading per $^{\circ}\text{C}$

Pot Position Input Specifications

Input Range:	0 to 100% rotation
End to end Resistance:	100Ω to $7\text{K}\Omega$
Calibration Accuracy:	$\pm 0.1\%$ of 'MeasV' parameter reading.
Noise:	$<0.01\%$ p-p with 1.6s Filter, $5\text{K}\Omega$ Pot. $<0.3\%$ p-p with 1.6s Filter, $100\text{K}\Omega$ Pot.
Resolution:	$<0.001\%$ with 1.6s Filter, $5\text{K}\Omega$ Pot.
Linearity:	Better than 0.01%
Temperature Coefficient:	$< 20\text{ppm}$ of reading per $^{\circ}\text{C}$

Note. Effective noise is related to filter and end-to-end resistance; higher resistance values are preferred.

General Specifications

Module power consumption:	2W max.
Common mode rejection:	$>120\text{db}$, 47 - 63Hz
Series mode rejection:	$>60\text{db}$, 47 - 63Hz
Isolation channel - channel:	Functional (basic insulation), 264Vac max
Isolation to system:	Reinforced (double insulation), 264Vac max

D2.5.3 AI2 mA Module

Input Types: 4 - 20 mA Current Loop.

Note. V and Ω ranges do not function when using the Shunt Terminal Unit.

Channel Specification

Input Range:	-30mA to +30mA
Calibration Accuracy:	$\pm 0.1\%$ of 'MeasV' parameter reading.
Noise:	$<1\mu\text{V}$ p-p with 1.6s Filter, better with longer time constants.
Resolution:	$<0.5\mu\text{V}$ with 1.6s Filter.
Linearity:	Better than $1\mu\text{V}$
Temperature Coefficient:	$< 50\text{ppm}$ of reading per $^{\circ}\text{C}$

General Specifications

Module power consumption:	2W max.
Common mode rejection:	$>120\text{db}$, 47 - 63Hz
Series mode rejection:	$>60\text{db}$, 47 - 63Hz
Isolation channel - channel:	Functional (basic insulation), 264Vac max
Isolation to system:	Reinforced (double insulation), 264Vac max

APPENDIX D3 AI3 - THREE CHANNEL ANALOGUE INPUT MODULE

D3.1 DESCRIPTION

The AI3 offers 3 isolated current input channels. The module hardware provides fixed range capable of $\pm 20\text{mA}$ at high resolution; configuration provides applications ranging. Each channel has an internal burden resistor requiring less than 1 volt and in most applications the inputs will be used for 4-20mA signals.

Each isolated channel will have its own 24V supply for external transmitter excitation.

Typical parameters which can be configured or changed include:

- Input Type
- Input Filter Time Constant
- User Calibration. This allows you to offset the 'permanent' factory calibration to:
 - a. Calibrate the controller to your reference standards
 - b. Match the calibration of the controller to that of a particular transducer or sensor
 - c. Calibrate the controller to suit the characteristics of a particular installation

Note The Sensor Break Protection of the channel is controlled via an associated AI_UIO block.

D3.2 TERMINAL CONNECTIONS

Connections are shown below for inputs where the transmitter requires excitation, and for those generating their own current. Each channel can be wired as required.

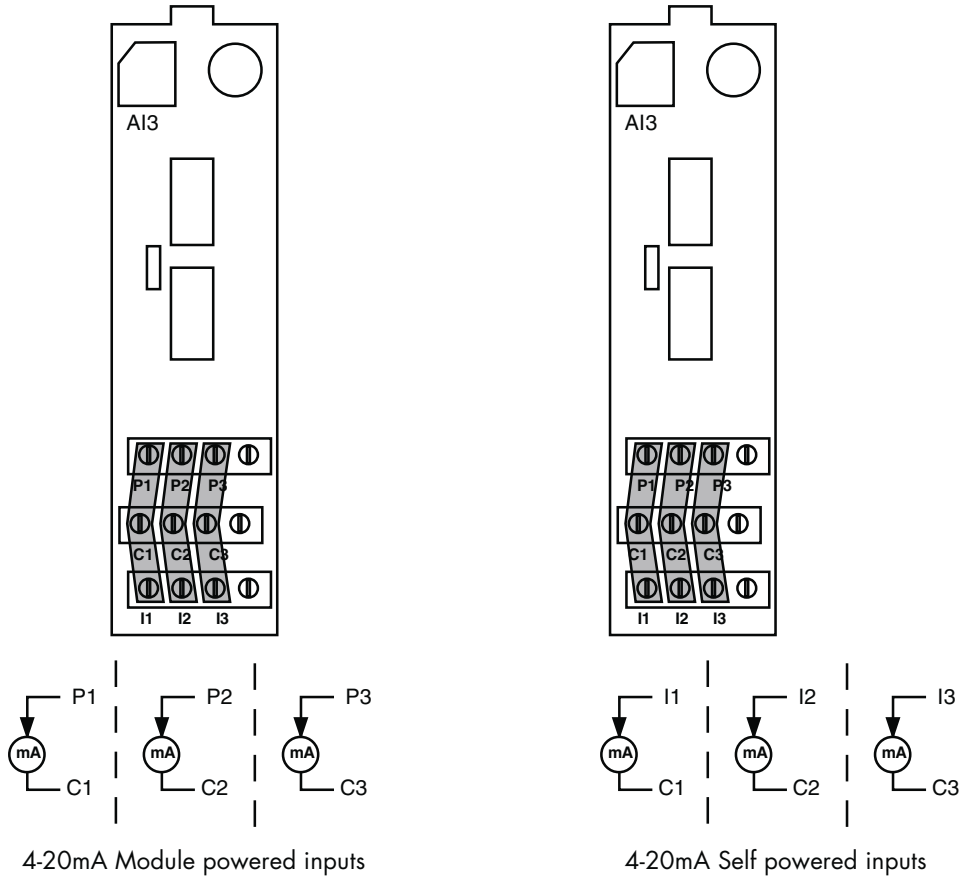

WIRING REDUNDANT MODULES

This module does not support redundant wiring operation.

Figure AI3-1 Three Channel Analogue Input Terminal Connections

D3.3 ANALOGUE INPUTS

D3.3.1 Isolation Diagram

Transducers can be directly wired into any appropriate channel at the terminals, but introduces safety implications, particularly risk of shock hazard. Electrical isolation minimizes such risks even when equipment goes faulty, and particularly when some transducers have to be run 'live'.

To provide effective operation a very simple isolation strategy is implemented in the form of a barrier separating all I/O channels in any I/O module from the rest of the system. This prevents hazardous voltages on any I/O channel introducing hazards on any wiring on another I/O module, or put at risk the rest of the system. Modules providing isolation channel-to-channel ensure safety and good signal quality on all channels.

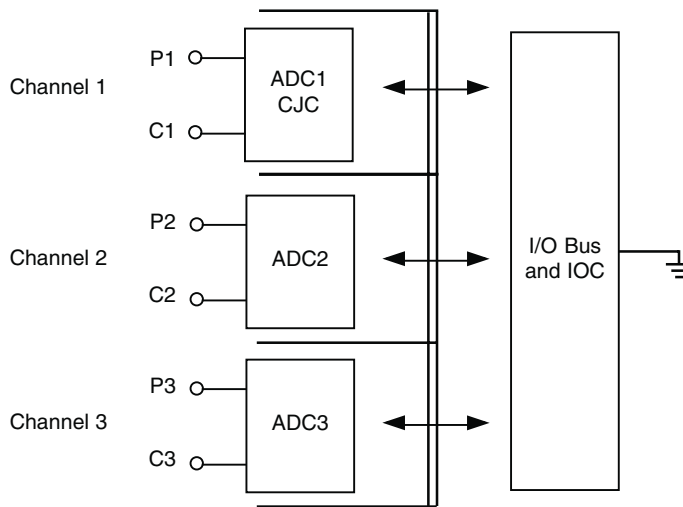

Figure AI3-2 Isolation Diagram

D3.3.2 Equivalent Circuits

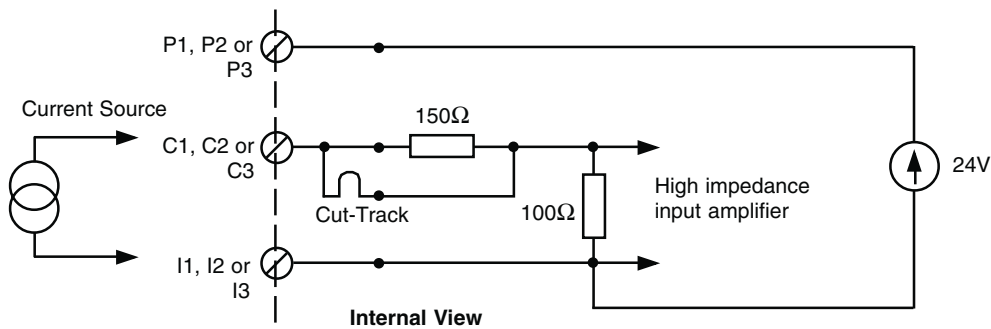

Figure AI3-3 mA Input

D3.4 HART COMPATIBILITY

The module does not directly support HART data extraction or injection functions.

The module is compatible with HART systems but with the following notes and provisos:

- The PSU is specified with a low AC impedance, so permitting normal HART connections (e.g., with master connected across the field device (near or far), or across the loop burden).
- Each channel offers full galvanic isolation, easing wiring and preventing HART signals from becoming interfering signals.
- Power Supply noise and ripple at HART frequencies are at very low amplitude, thus minimising risk of interference with HART signals.
- For HART loops where the main burden resistor is that provided by the AI3, the resistor must be padded with an external series resistor, normally by adding 150Ω in series with the *Cn* connection. This can be achieved by cutting the track as shown in Figure AI3-2. The resistor can be wired using the spare terminals and wire-ended resistors. Such padding does not affect the specification, except in that the excess input voltage would reduce the headroom required to power external devices (as would all HART compliant loops).

D3.5 STATUS INDICATION

The status of the module is shown by four LED indicators as follows:

*Note. * - IOC firmware prior to software issue 2.21 will not recognise an AI3 module.*

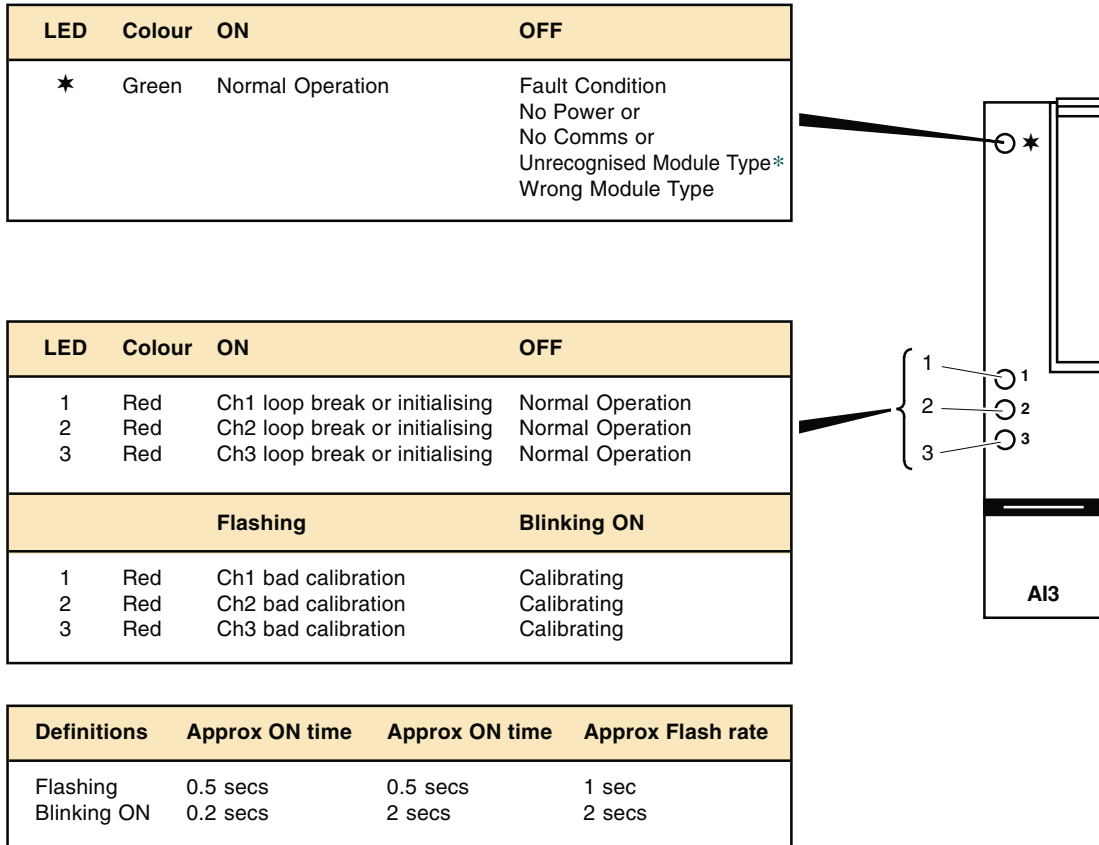

Figure AI3-4 Three Channel Analogue Input Status Indication

D3.6 SPECIFICATIONS

D3.6.1 AI3 Module

Input Types: 4 - 20 mA Current Loop with exciter PSU.

Channel Specification

Input Range:	-28mA to +28mA
Calibration Accuracy:	± 0.1% of 'MeasV' parameter reading
Noise:	<1 μ V p-p with 1.6s Filter
Resolution:	<0.5 μ V with 1.6s Filter
Linearity:	Better than 0.7 μ A
Temperature Coefficient:	< 50ppm per °C of reading per °C
Burden Resistor:	100 Ω , 50mA max current
Channel PSU:	22V min to 29V max.
PSU Protection:	30mA (nom) current trip, auto reset.

General Specifications

Module power consumption:	4W max.
Common mode rejection:	>120db, 47 - 63Hz
Series mode rejection:	>60db, 47 - 63Hz
Isolation channel - channel:	Functional (basic insulation), 50Vac max
Isolation to system:	Reinforced (double insulation), 264Vac max

APPENDIX D4 AI4 - FOUR CHANNEL ANALOGUE INPUT MODULE

D4.1 DESCRIPTION

The analogue input module is used to measure analogue signals from a range of plant sensors.

These include:

- Thermocouples
- Voltage +100mV
- Current +20mA.

The analogue input module consists of four input channels, isolated in pairs of channels (1 and 2 from 3 and 4) each channel pair having independent termination but sharing a common connection and all channels isolated from the system electronics.

For thermocouple inputs Cold Junction Temperature is measured by a RTD sensor fitted to the terminal unit.

Typical parameters that can be configured or changed include:

- Input Type
- Range
- Input Filter Time Constant
- User Calibration. This allows you to offset the 'permanent' factory calibration to:
 - a. Calibrate the controller to your reference standards
 - b. Match the calibration of the controller to that of a particular transducer or sensor
 - c. Calibrate the controller to suit the characteristics of a particular installation

Note The Sensor Break Protection of the channel is controlled via an associated AI_UIO block. Channel 1 and Channel 3 support Up, None, or Down Sensor Break Action, and Channel 2 and Channel 4 support Up Sensor Break Action only.

D4.2 TERMINAL CONNECTIONS

Connections are shown below for inputs where the transmitter requires excitation, and for those generating their own current. Each channel can be wired as required.

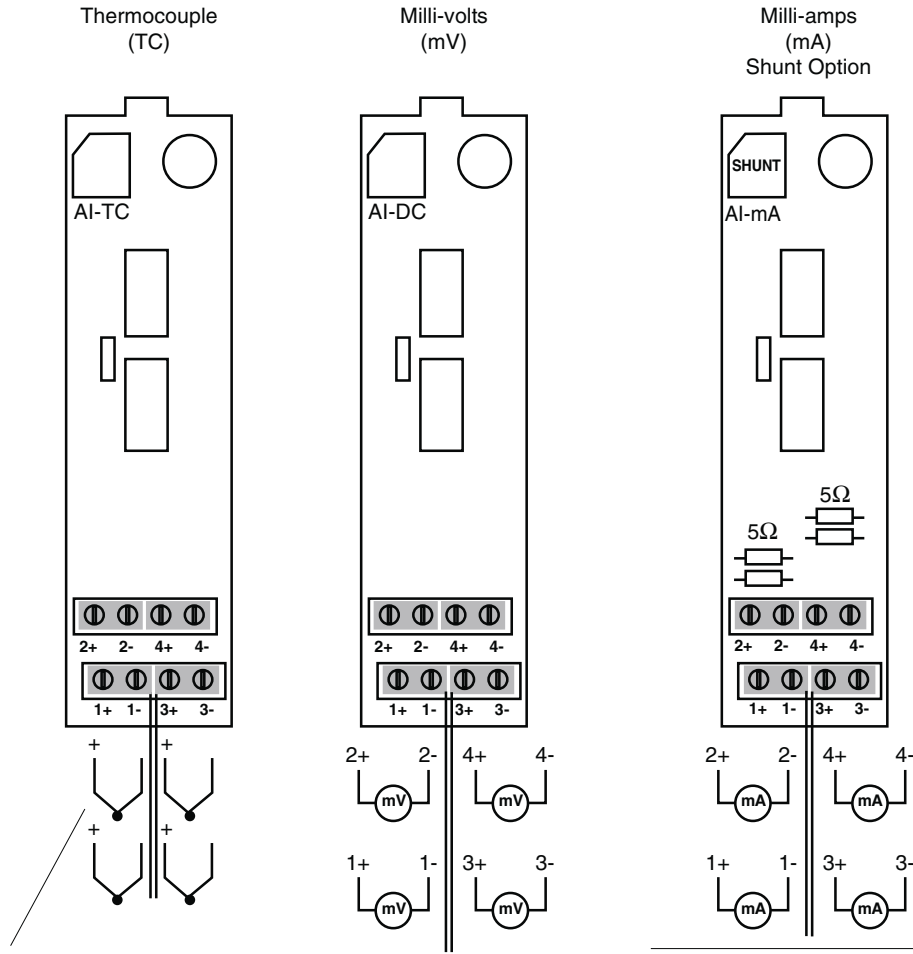

Note If the AI module is configured as thermocouple input on one channel and + mV inputs on the others, the thermocouple must be connected to channel 1.

Note The shunt option has 5Ω resistors mounted on the PCB. The mV option may also be used for mA inputs if fitted with suitable 5Ω external burden resistors. It permits a 0-20mA input to provide a full scale range of 0-100mV.

WIRING REDUNDANT MODULES

This module does support redundant wiring operation, see 2500M I/O Module Redundant Configuration Handbook.

D4.3 ANALOGUE INPUTS

D4.3.1 Isolation Diagram

Transducers can be directly wired into any appropriate channel at the terminals, but introduces safety implications, particularly risk of shock hazard. Electrical isolation minimizes such risks even when equipment goes faulty, and particularly when some transducers have to be run 'live'.

To provide effective operation a very simple isolation strategy is implemented in the form of a barrier separating all I/O channels in any I/O module from the rest of the system. This prevents hazardous voltages on any I/O channel introducing hazards on any wiring on another I/O module, or put at risk the rest of the system. Modules providing isolation channel-to-channel ensure safety and good signal quality on all channels.

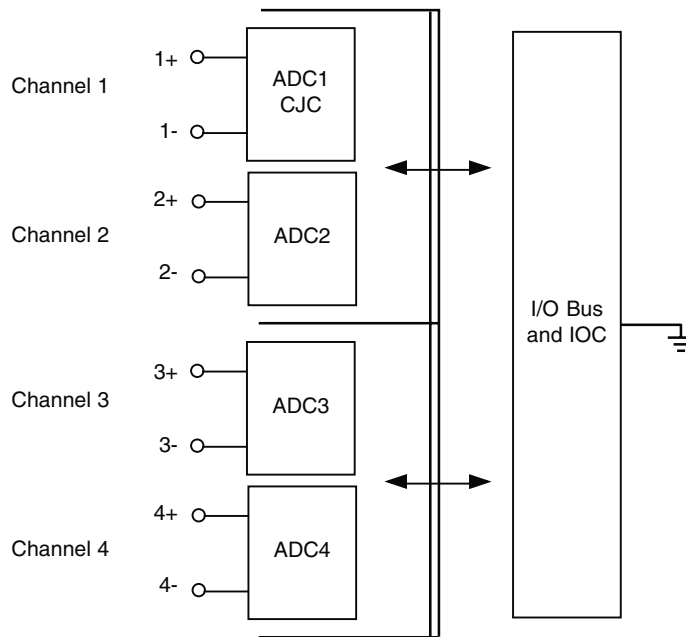

Figure AI4-2 Isolation Diagram

D4.3.2 Equivalent Circuits

The equivalent circuits below show details of analogue inputs, in particular sensor break circuits.

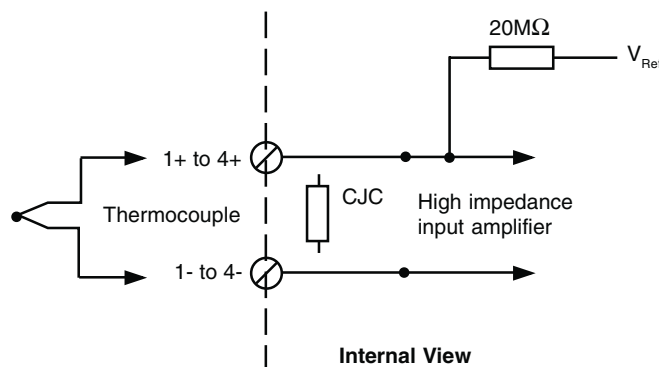

Figure AI4-3 Thermocouple Input

D4.3 ANALOGUE INPUTs (Cont.)

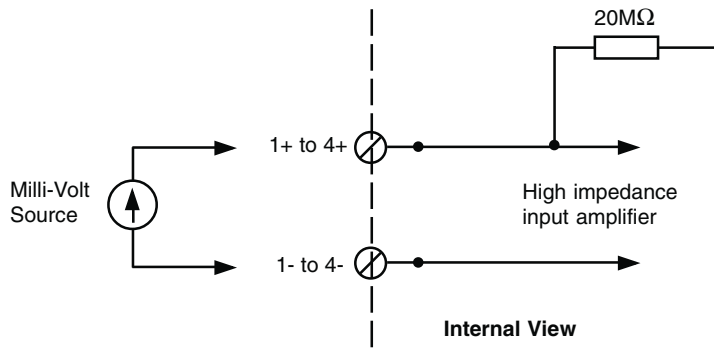

Figure AI4-4 mV Input

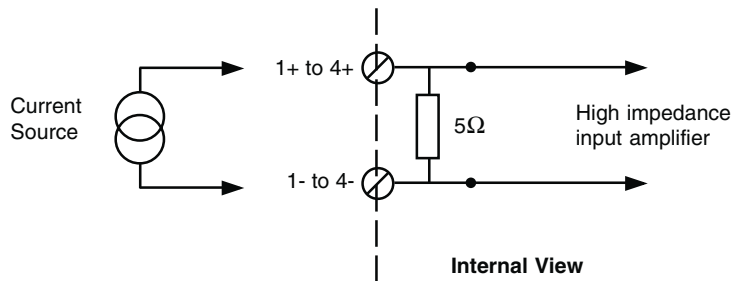

Figure AI4-5 mA Input

D4.4 STATUS INDICATION

The status of the module is shown by three LED indicators as follows:

LED	Colour	ON	OFF
*	Green	Normal Operation	Fault Condition - No Power or No Comms or Wrong Module Type

LED	Colour	ON	OFF
1	Red	Ch1/2 sensor break or initialising	Normal Operation
2	Red	Ch3/4 sensor break or initialising	Normal Operation
		Flashing	Blinking ON
1	Red	Ch1/2 CJC fail or Ch1 bad cal data	Calibrating
2	Red	Ch3/4 CJC fail or Ch2 bad cal data	Calibrating

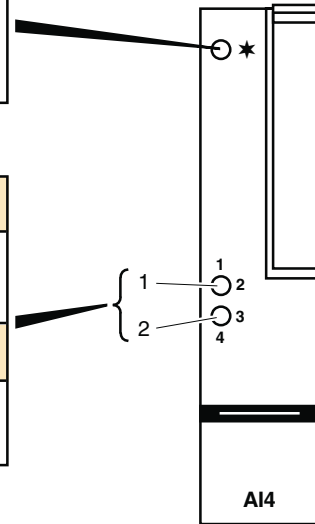

Definitions	Approx ON time	Approx OFF time	Approx Flash rate
Flashing	0.5 secs	0.5 secs	1 sec
Blinking ON	0.2 secs	2 secs	2 secs

Figure AI4-6 Four Channel Analogue Input Status Indication

D4.5 SPECIFICATIONS

Values given with respect to V_s , where V_s is an externally supplied voltage, nominally 24V. Plant Side Interface.

D4.5.1 AI4 TC Module

Input Types: mVdc (optimised for thermocouples)

mV Input Specification

Input Range:	-150mV to +150mV.
Calibration Accuracy:	$\pm 0.1\%$ of 'MeasV' parameter reading, $\pm 10\mu\text{V}$.
Noise:	$<4\mu\text{V}$ p-p with 1.6s Filter, better with longer time constants.
Resolution:	$<2\mu\text{V}$ with 1.6s Filter.
Linearity:	Better than $5\mu\text{V}$.
Temperature Coefficient:	$< 40\text{ppm}$ of reading per $^{\circ}\text{C}$.
Input Impedance:	$>20\text{M}\Omega$ (break detect circuit to +2.5V).
Input Leakage Current:	-125nA (break detect drive)

Cold Junction Sensor Specification

Cold Junction Range:	-10°C to $+70^{\circ}\text{C}$
CJ Rejection:	$> 30:1$
CJ Accuracy:	$\pm 0.5^{\circ}\text{C}$ ('Automatic' cold junction compensation)
Sensor Type:	Pt100 resistor, under the TU wiring terminals.

General Specifications

Module power consumption:	2W max.
Common mode rejection:	$>120\text{db}$, 47 - 63Hz
Series mode rejection:	$>60\text{db}$, 47 - 63Hz
Isolation channel - channel:	Ch1 connected to Ch2, and Ch3 connected to Ch4 - Functional (basic insulation) separates the CH1, CH2 pair from the CH3, CH4 pair, 264Vac max
Isolation to system:	Reinforced (double insulation), 264Vac max

D4.5.2 AI4 mV Module

Input Types: mV dc input (where CJC is not required).

Channel Specification

Input Range:	-150mV to +150mV
Calibration Accuracy:	$\pm 0.1\%$ of 'MeasV' parameter reading, $\pm 10\mu\text{V}$.
Noise:	$<4\mu\text{V}$ p-p with 1.6s Filter, better with longer time constants.
Resolution:	$<2\mu\text{V}$ with 1.6s Filter.
Linearity:	Better than $5\mu\text{V}$
Temperature Coefficient:	$< 40\text{ppm}$ of reading per $^{\circ}\text{C}$
Input Impedance:	$>20\text{M}\Omega$ (break detect circuit to +2.5V)
Input Leakage Current:	-125nA (break detect drive)

General Specifications

Module power consumption:	2W max.
Common mode rejection:	$>120\text{db}$, 47 - 63Hz
Series mode rejection:	$>60\text{db}$, 47 - 63Hz
Isolation channel - channel:	Ch1 connected to Ch2, and Ch3 connected to Ch4 - Functional (basic insulation) separates the CH1, CH2 pair from the CH3, CH4 pair, 264Vac max
Isolation to system:	Reinforced (double insulation), 264Vac max

D4.5.3 AI4 mA Module

Input Types: 4 - 20 mA Current Loop.

Channel Specification

Input Range:	-30mA to +30mA
Calibration Accuracy:	$\pm 0.1\%$ of 'MeasV' parameter reading, $\pm 2\mu\text{A}$.
Noise:	$<1\mu\text{V}$ p-p with 1.6s Filter, better with longer time constants.
Resolution:	$<0.5\mu\text{V}$ with 1.6s Filter.
Linearity:	Better than $1\mu\text{V}$.
Temperature Coefficient:	$< 50\text{ppm}$ of reading per $^{\circ}\text{C}$
Burden Resistor:	$5\Omega \pm 0.1\%$ (fitted to Terminal Unit)

General Specifications

Module power consumption:	2W max.
Common mode rejection:	$>120\text{db}$, 47 - 63Hz
Series mode rejection:	$>60\text{db}$, 47 - 63Hz
Isolation channel - channel:	Ch1 connected to Ch2, and Ch3 connected to Ch4 - Functional (basic insulation) separates the CH1, CH2 pair from the CH3, CH4 pair, 264Vac max
Isolation to system:	Reinforced (double insulation), 264Vac max

APPENDIX D5 AO2 - TWO CHANNEL ANALOGUE OUTPUT MODULE

D5.1 DESCRIPTION

The analogue output module provides two analogue output channels, isolated from each other and isolated from the system electronics. Each output may be configured as either voltage or current.

Typical operating outputs which can be configured include:

- 10V 5mA max
- 20mA 12V dc max
- 5V 10mA max
- Output range limit 30V max, 40mA max.

D5.2 TERMINAL CONNECTIONS

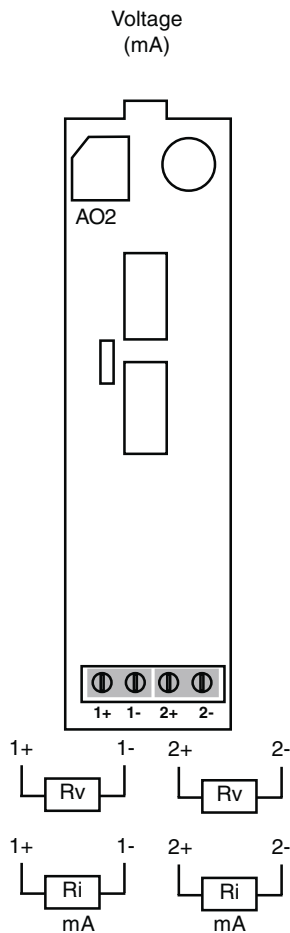

Notes.

1. **Voltage Mode.** The input impedance 'Rv' of the device connected to the Analogue Output module must be $> 550\Omega$ for 0Vdc to 10Vdc range and $> 1500\Omega$ for the -0.1Vdc to +10.1Vdc range.
2. **Current Mode.** The input impedance (or loop impedance) 'Ri' of the device connected to the Analogue Output module must be $< 550\Omega$.

REDUNDANT OUTPUT WIRING

This module does support redundant wiring operation , see 2500M I/O Module Redundant Configuration Handbook.

D5.3 ANALOGUE OUTPUTS

D5.3.1 Isolation Diagram

Transducers can be directly wired into any appropriate channel at the terminals, but introduces safety implications, particularly risk of shock hazard. Electrical isolation minimizes such risks even when equipment goes faulty, and particularly when some transducers have to be run 'live'.

To provide effective operation a very simple isolation strategy is implemented in the form of a barrier separating all I/O channels in any I/O module from the rest of the system. This prevents hazardous voltages on any I/O channel introducing hazards on any wiring on another I/O module, or put at risk the rest of the system. Modules providing isolation channel-to-channel ensure safety and good signal quality on all channels.

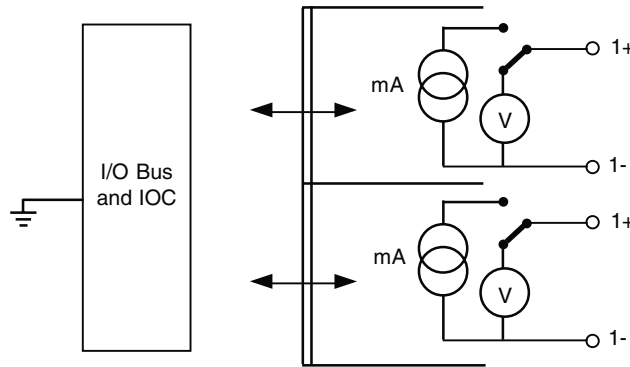

Figure AO2-2 Isolation Diagram

D5.3.2 Equivalent Diagram

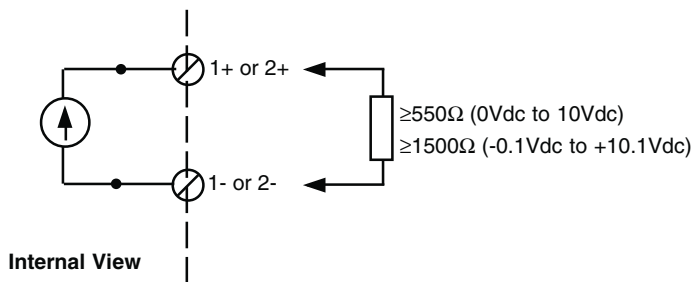

Figure AO2-3 Voltage Output

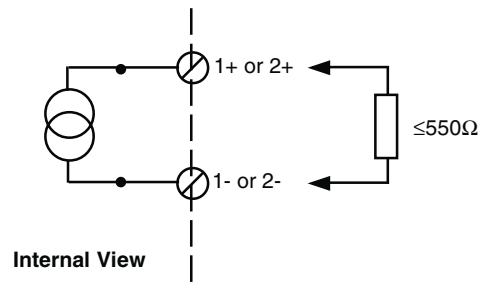

Figure AO2-4 Current Output

D5.4 STATUS INDICATION

The status of the module is shown by three LED indicators as follows:

LED	Colour	ON	OFF
*	Green	Normal Operation	Fault Condition - No Power or No Comms or Wrong Module Type

LED	Colour	ON	OFF
1	Red	Ch1 saturated or initialising	Normal Operation
2	Red	Ch2 saturated or initialising	Normal Operation
		Flashing	Blinking ON
1	Red	Ch1 bad cal data	Calibrating
2	Red	Ch2 bad cal data	Calibrating

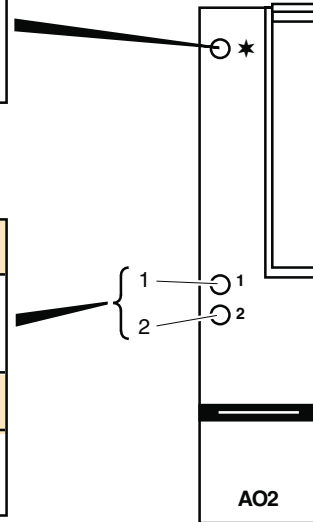

Definitions	Approx ON time	Approx OFF time	Approx Flash rate
Flashing	0.5 secs	0.5 secs	1 sec
Blinking ON	0.2 secs	2 secs	2 secs

Figure AO2-5 Two Channel Analogue Output Status Indication

D5.5 SPECIFICATIONS

Values given with respect to V_s , where V_s is an externally supplied voltage, nominally 24V.

D5.5.1 AO2 Module

Output Types: 4-20mA loop current or 0-10Vdc, software selected.

Current Output Specification

Output Range:	0mA to +20mA
Output Load Limits:	0 Ω to 550 Ω
Calibration Accuracy:	Better than $\pm 0.1\%$ of reading
Linearity:	0.003% of range (0.7 μ A)
Resolution:	better than 1 part in 10000 (1 μ A typical)

Voltage Output Specification

Output Range:	0Vdc to +10Vdc, -0.1Vdc to +10.1Vdc
Output Load Limits:	550 Ω or higher, 1500 Ω or higher respectively
Calibration Accuracy:	Better than $\pm 0.1\%$ of reading
Linearity:	0.003% of range (0.3mV)
Resolution:	better than 1 part in 10000 (0.5mV typical)

General Specification

Module power consumption:	2.2W max.
Isolation channel - channel:	Functional (basic insulation), 264Vac max
Isolation to system:	Reinforced (double insulation), 264Vac max

Figure AI4-6 Four Channel Analogue Input Status Indication

Intentionally left blank

APPENDIX D6 DI4 - FOUR CHANNEL DIGITAL INPUT MODULE

D6.1 DESCRIPTION

The Four Channel Digital Input Module accepts four logic inputs which may be either from a voltage source or a contact closure.

For voltage source inputs, the ON state requires between +10.8V and + 30V, and the OFF state requires $\leq +5V$.

For contact closure inputs, an external power supply of between +18V and +30V is required at a current rating suitable for the size of the system (This module provides a transient current of 100mA for 1mS at the point of switching).

A suitable 24V DIN rail mounted power supply, is the 2500P/2A5 rated at 2.5 amps, 2500P/5A0 rated at 5 amps or 2500P/10A rated at 10 amps, - see *2500P module*.

A limited number of parameters are required to be configured in this module, such as:-

- Contact bounce suppression

D6.2 TERMINAL CONNECTIONS

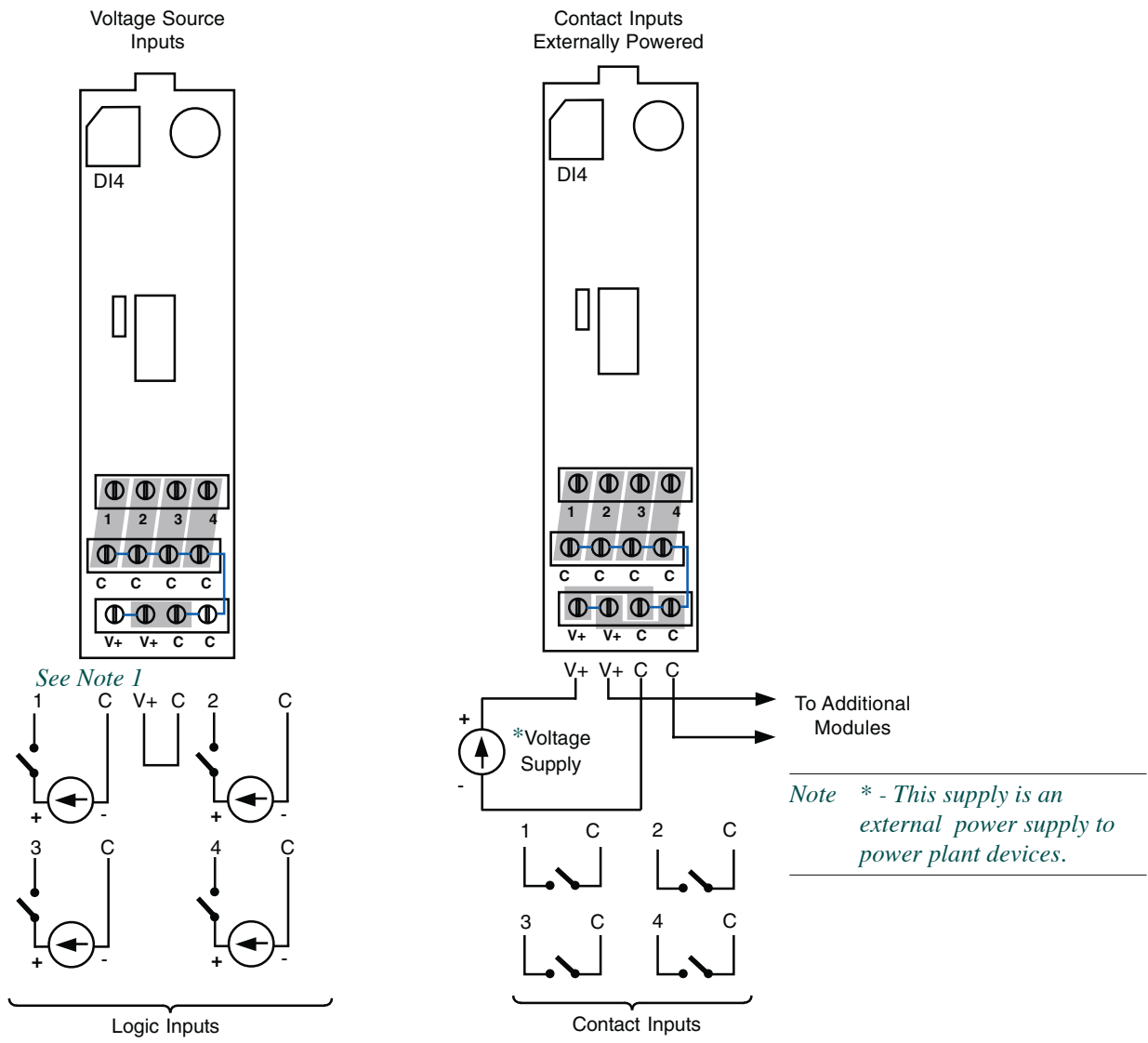

WIRING REDUNDANT MODULES

This module does support redundant wiring operation, see 2500M I/O Module Redundant Configuration Handbook.

Figure DI4-1 Four Channel Digital Input Module Terminal Connections

D6.3 DIGITAL INPUTS

D6.3.1 Isolation Diagram

Transducers can be directly wired into any appropriate channel at the terminals, but introduces safety implications, particularly risk of shock hazard. Electrical isolation minimizes such risks even when equipment goes faulty, and particularly when some transducers have to be run 'live'.

To provide effective operation a very simple isolation strategy is implemented in the form of a barrier separating all I/O channels in any I/O module from the rest of the system. This prevents hazardous voltages on any I/O channel introducing hazards on any wiring on another I/O module, or put at risk the rest of the system. Modules providing isolation channel-to-channel ensure safety and good signal quality on all channels.

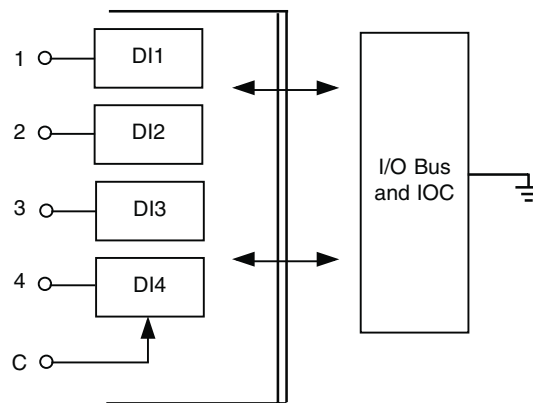

Figure DI4-2 Isolation Diagram

D6.3.2 Equivalent Circuits

The equivalent circuits below show the input into the Four Channel Digital Input Module for purposes of determining the source conditions.

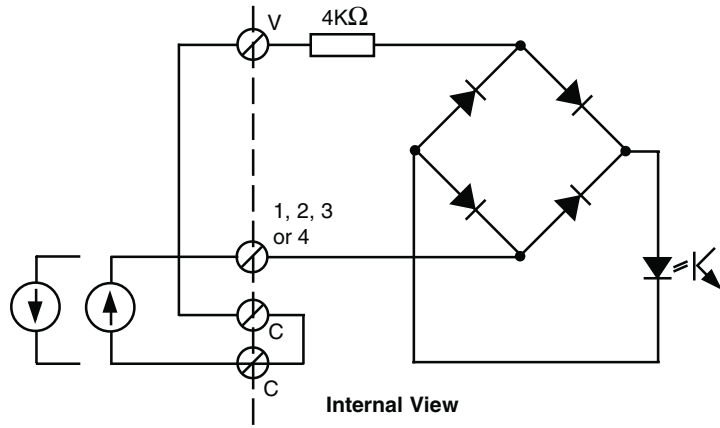

Figure DI4-3 Logic Input Equivalent Circuit

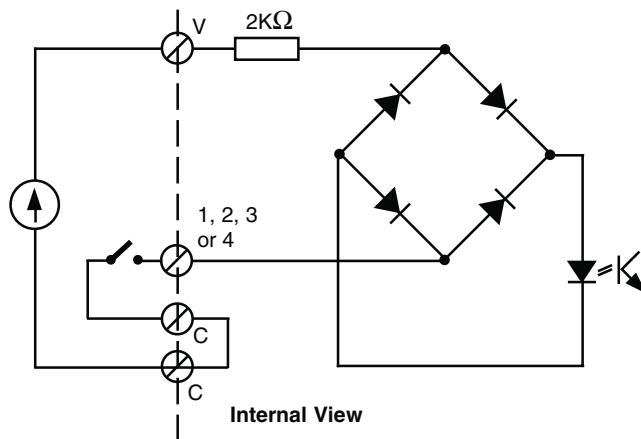

Figure DI4-4 Contact Closure Input Equivalent Circuit

D6.4 STATUS INDICATION

The status of the module is shown by five LED indicators as follows:

Note When the module is reset all LEDs are lit for 1sec for test purposes.

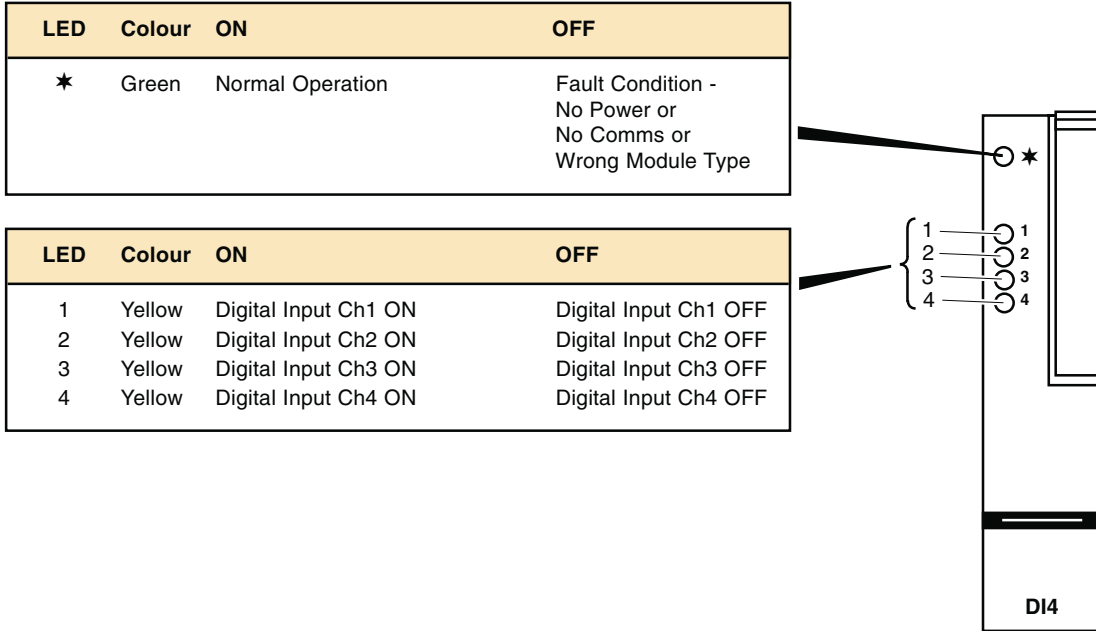

Figure DI4-5 Four Channel Digital Input Module Status Indication

D6.5 SPECIFICATIONS

The DI4 offers four logic channels for voltage input or for switch contact input. For the latter a 24V supply is required; for logic input the supply must be shorted. This configuration determines the function for all four channels.

D6.5.1 DI4 Module

Channel Types: On/Off, Pulse, Debounce.

Logic Input Specification

Input Logic 0 (Off):	<5Vdc
Input Logic 1 (On):	>10.8Vdc
Input Operating Range:	-5Vdc to +30Vdc
Input Current:	2.5mA (approx) at 10.5V; 10mA max @ 30V.

Note "Logic" operation requires a short across V+ and C terminals, setting the mode for the whole module.

Contact Input Specification

Contact Mode PSU (Vcs):	18Vdc to 30Vdc, 24V nom.
Contact Input 0 (Off):	>28K Ω
Contact Input 1 (On):	<100 Ω
Contact Current:	8mA typical at 200 Ω contact, 16mA max s/c contact

Note "Contact" mode requires 24Vdc across the V+ and C terminals, setting the mode for the whole module.

General Specification

Module power consumption:	0.45W max
Isolation channel - channel:	N/A (Channels share common connections)
Isolation to system:	Reinforced (double insulation), 264Vac max

APPENDIX D7 DI6 - SIX CHANNEL AC DIGITAL INPUT MODULE

D7.1 DESCRIPTION

This Six Channel Digital Input Module accepts six isolated mains ac, logic input signals and is available in two variants for 230 volts AC. (DI6 230V AC) or 115 volts AC (DI6 115V AC). The two versions are factory assembled options and cannot be converted in the field.

Inadvertent use of the wrong module is unlikely to cause damage. However, prolonged use of the 115 volt option at 230 volts will cause higher than recommended power dissipation and if working close to the maximum ambient operating temperature, damage may occur. This mode of operation is NOT recommended.

Using a 230 volt unit on 115 volt AC, will not cause damage, but as 115 volt AC does not exceed the active state minimum voltage for 'ON', there is no guarantee the 'ON' state will be detected.

A limited number of parameters are required to be configured in this module, such as:-

- Contact bounce suppression.

D7.2 TERMINAL CONNECTIONS

115 and 230 Volt AC
Inputs

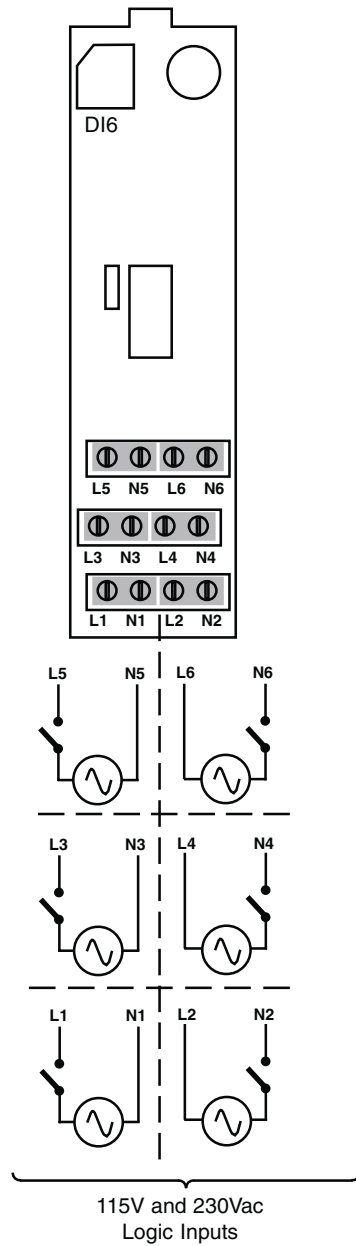

WIRING REDUNDANT MODULES

This module does not currently support redundant wiring operation.

Figure DI6-1 Six Channel AC Digital Input Module Terminal Connections

D7.2.1 V-I CURVES FOR INPUTS

The graphs below show the minimum and maximum input voltages which will guarantee OFF and ON conditions respectively for 230V and 115V operation. For the input to correctly indicate a transition the input must exceed the voltage threshold and concurrently the source must be capable of supplying more than 2mA.

Current taken by the input against input switching voltage assuming 230Vac operation.

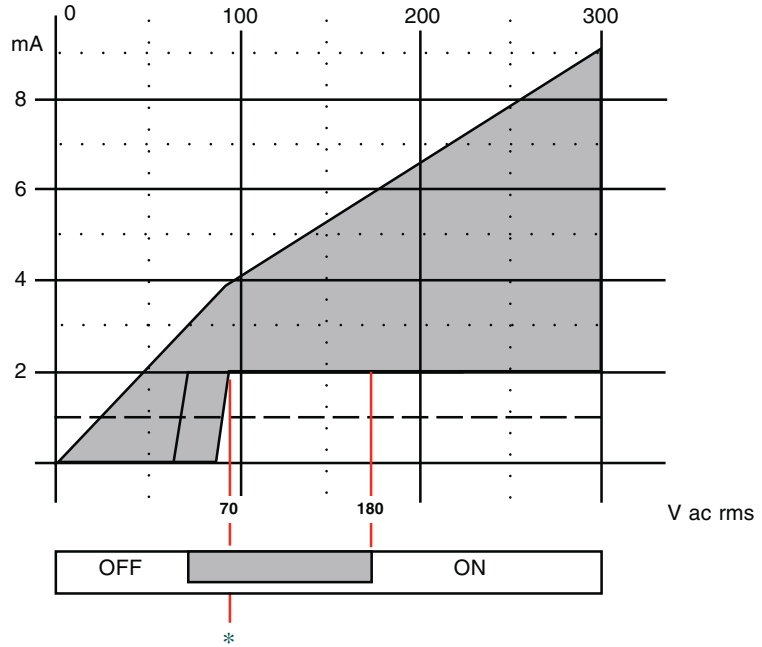

*Note * - The threshold may vary between V_{maxoff} and V_{minon} . I_{off} is defined at the threshold.*

Figure DI6-2a V-I curve for 230Vac operation

Current taken by the input against input switching voltage assuming 115Vac operation.

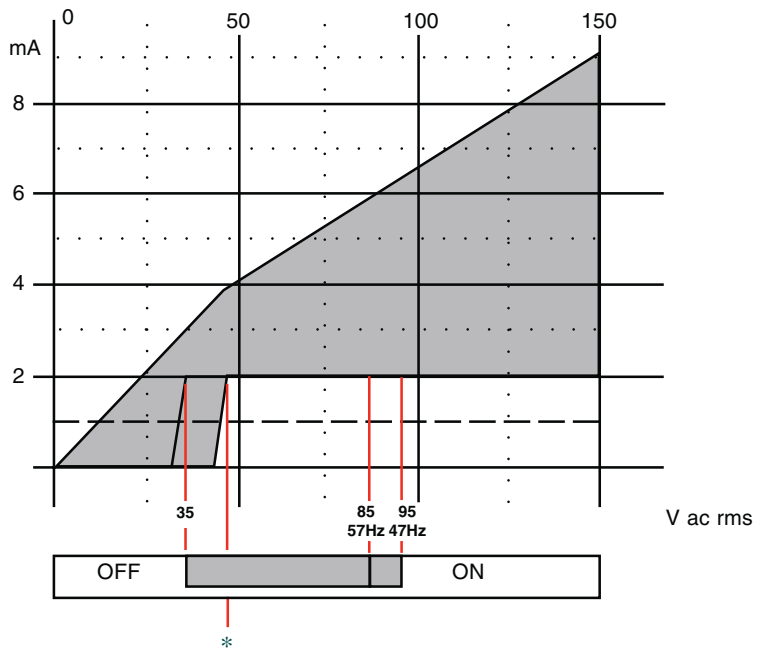

*Note * - The threshold may vary between V_{maxoff} and V_{minon} . I_{off} is defined at the threshold.*

Figure DI6-2b V-I curve for 115Vac operation

D7.3 DIGITAL INPUTS

D7.3.1 Isolation Diagram

Transducers can be directly wired into any appropriate channel at the terminals, but introduces safety implications, particularly risk of shock hazard. Electrical isolation minimizes such risks even when equipment goes faulty, and particularly when some transducers have to be run 'live'.

To provide effective operation a very simple isolation strategy is implemented in the form of a barrier separating all I/O channels in any I/O module from the rest of the system. This prevents hazardous voltages on any I/O channel introducing hazards on any wiring on another I/O module, or put at risk the rest of the system. Modules providing isolation channel-to-channel ensure safety and good signal quality on all channels.

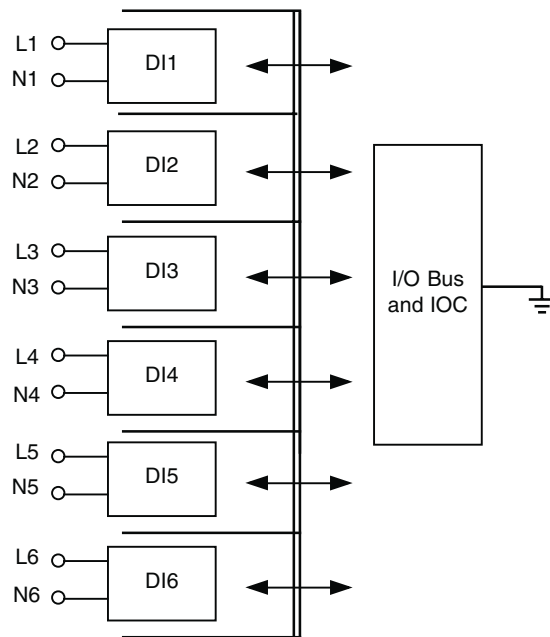

Figure DI6-3 Isolation Diagram

D7.3.2 Equivalent Circuits

The equivalent circuits below show the input into the Six Channel Digital Input Module for purposes of determining the source conditions.

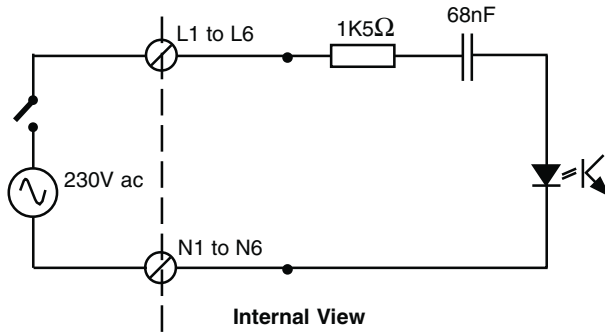

Figure DI6-4 230V ac Digital Input Equivalent Circuit

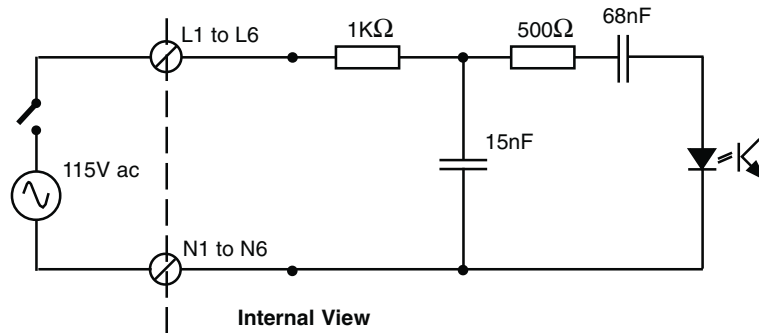

Figure DI6-5 115V ac Digital Input Equivalent Circuit

D7.4 STATUS INDICATION

The status of the module is shown by seven LED indicators as follows:

Notes

1. * - Only applicable after software version 3.26.
2. When the module is reset all LEDs are lit for 1sec for test purposes.

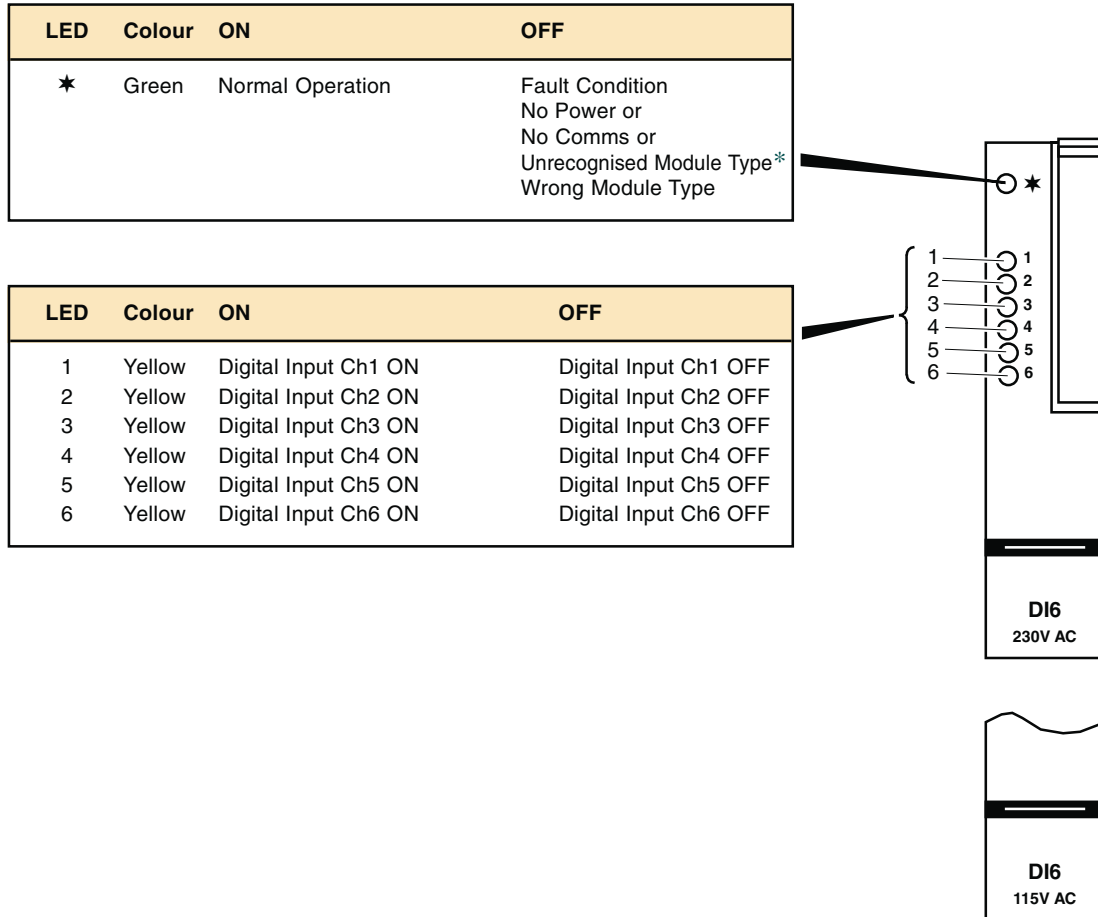

Figure DI6-6 Six Channel AC Digital Input Module Status Indication

D7.5 SPECIFICATIONS

D7.5.1 DI6 Module

Channel Types: 115V and 230V - On/Off, Pulse, Debounce.

Channel Specification

Input Logic 0 (Off):	115Vac - <35Vac, 47Hz - 63Hz. 230Vac - <70Vac, 47Hz - 63Hz.
Input Logic 1 (On):	115Vac - <95Vac, 47Hz - 63Hz. 230Vac - <180Vac, 47Hz - 63Hz.
Input Operating Range:	115Vac - 0 to 150Vac. 230Vac - 264Vac.
Maximum Input Current:	115Vac - 8mA rms @ 150Vac. 230Vac - 9mA rms @ 264V.
Minimum Input Current:	115Vac - Logic 0 forced for any current < 2mA rms. 230Vac - Logic 0 forced for any current < 2mA rms.

General Specification

Module power consumption:	0.45W max
Detectable Pulse Width:	3 cycles min
Debounce Time:	20ms to 2.55s
Isolation channel - channel:	Functional (basic insulation), 264 Vac max.
Isolation to system:	Reinforced (double insulation), 264Vac max

Intentionally left blank

APPENDIX D8 DI8 - EIGHT CHANNEL DIGITAL INPUT MODULE

D8.1 DESCRIPTION

The Eight Channel Digital Input Module accepts eight digital inputs which may be either from a voltage source (DI8_{LOGIC}) or contact closure (DI8_{CONTACT}). The two versions are factory assembled options and cannot be converted in the field.

For the DI8_{LOGIC} option (voltage source inputs), the ON state requires between +10.8V to + 30V, and the OFF state requires between -3V and +5V.

For the DI8_{CONTACT} option (contact closure inputs), an internal supply is provided which provides an open circuit wetting voltage of at least 9V. The input is ON if the contact resistance is < 100Ω , OFF if it is > 10kΩ.

A limited number of parameters are required to be configured in this module, such as:-

- Contact bounce suppression.

D8.2 TERMINAL CONNECTIONS

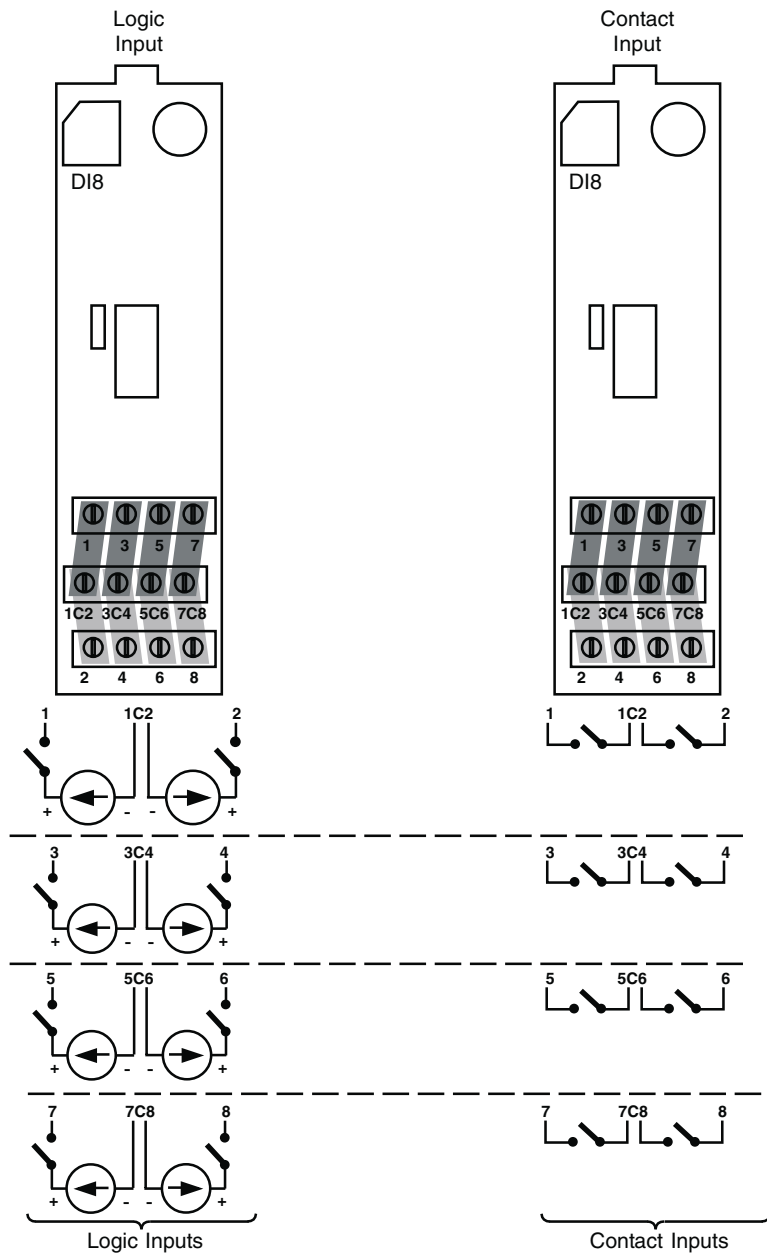

REDUNDANT INPUT WIRING

This module does support redundant wiring operation , see 2500M I/O Module Redundant Configuration Handbook.

D8.3 DIGITAL INPUTS

D8.3.1 Isolation Diagram

Transducers can be directly wired into any appropriate channel at the terminals, but introduces safety implications, particularly risk of shock hazard. Electrical isolation minimizes such risks even when equipment goes faulty, and particularly when some transducers have to be run 'live'.

To provide effective operation a very simple isolation strategy is implemented in the form of a barrier separating all I/O channels in any I/O module from the rest of the system. This prevents hazardous voltages on any I/O channel introducing hazards on any wiring on another I/O module, or put at risk the rest of the system. Modules providing isolation channel-to-channel ensure safety and good signal quality on all channels.

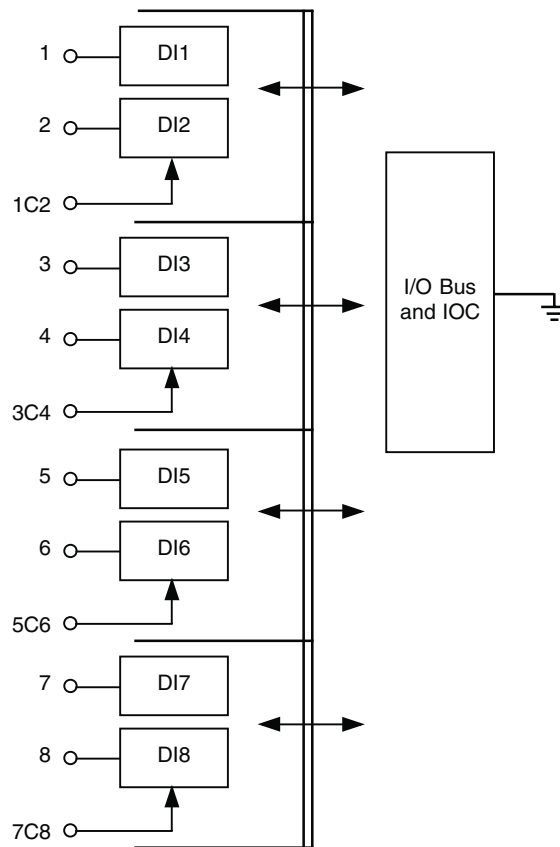

Figure DI8-3 Isolation Diagram

D8.3.2 Equivalent Circuits

The equivalent circuits below show the input into the Eight Channel Digital Input Module for purposes of determining the source conditions.

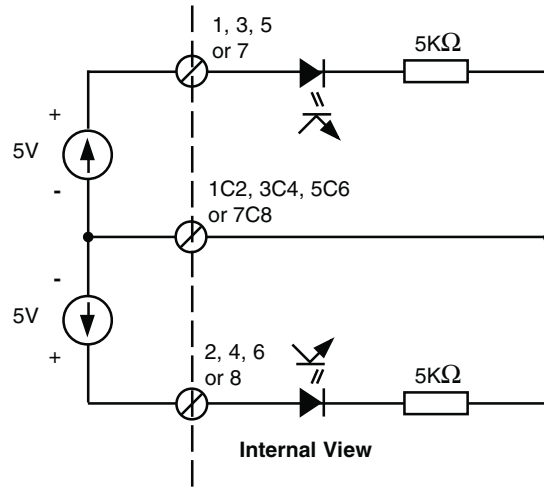

Figure DI8-3 Logic Input Equivalent Circuit

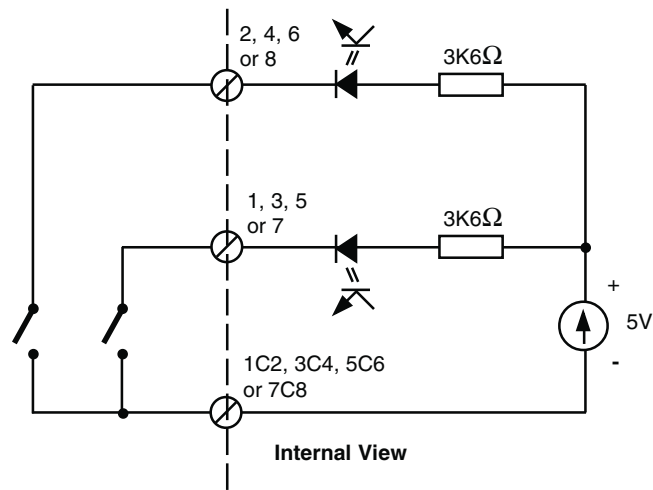

Figure DI8-4 Contact Closure Input Equivalent Circuit

D8.4 STATUS INDICATION

The status of the module is shown by nine LED indicators as follows:

Note

1. * - IOC firmware prior to software issue 2.10 will not recognise an AI3 module.
2. When the module is reset all LEDs are lit for 1sec for test purposes.

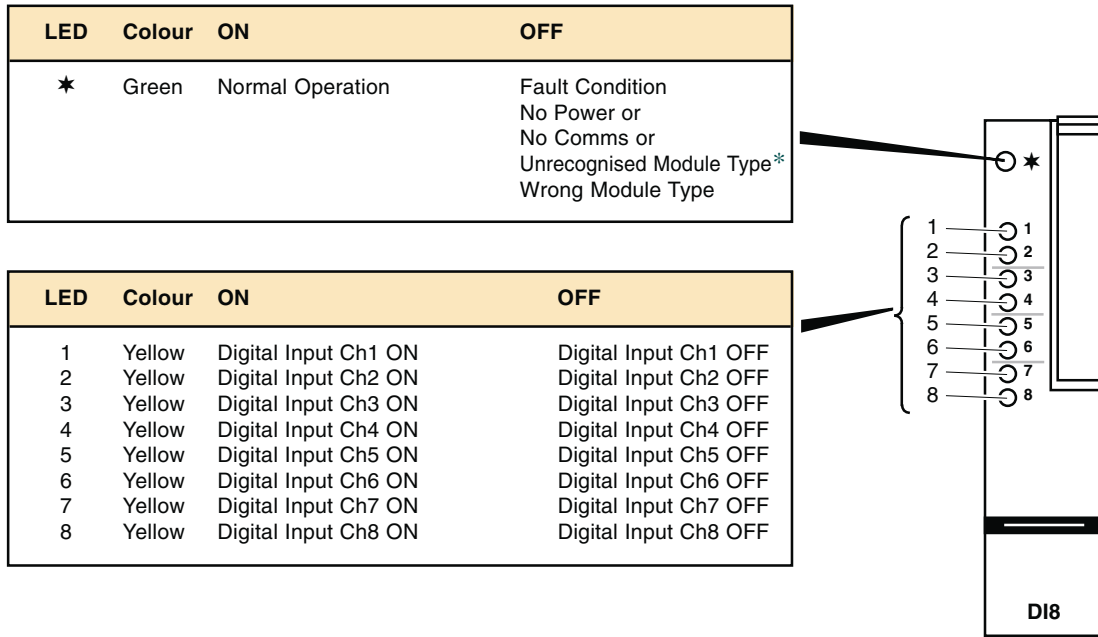

Figure DI8-5 Eight Channel Digital Input Module Status Indication

D8.5 SPECIFICATIONS

D8.5.1 D18 Module

Channel Types: On/Off, Pulse, Debounce.

Input Types: Logic (24Vdc), Contact (switch resistance).

Logic Input Specification

Input Logic 0 (Off):	<5Vdc
Input Logic 1 (On):	>10.8Vdc
Input Operating Range:	-5Vdc to +30Vdc
Input Current:	2mA (approx) at 10.5Vdc; 10mA max @ 30Vdc.

Contact Input Specification

Contact Input 0 (Off):	>28K Ω
Contact Input 1 (On):	<100 Ω
Contact current:	2mA nominal at 100 Ω , 10mA max short-circuit.

General Specification

Module power consumption:	1W max					
Detectable Pulse Width:	20ms min					
Debounce Time:	20ms to 2.55s					
Isolation channel - channel:	<table> <tr> <td>Ch1 connected to Ch2</td> <td rowspan="4">} Functional (basic insulation) separates these pairs, 50V max</td> </tr> <tr> <td>Ch3 connected to Ch4</td> </tr> <tr> <td>Ch5 connected to Ch6</td> </tr> <tr> <td>Ch7 connected to Ch8</td> </tr> </table>	Ch1 connected to Ch2	} Functional (basic insulation) separates these pairs, 50V max	Ch3 connected to Ch4	Ch5 connected to Ch6	Ch7 connected to Ch8
Ch1 connected to Ch2	} Functional (basic insulation) separates these pairs, 50V max					
Ch3 connected to Ch4						
Ch5 connected to Ch6						
Ch7 connected to Ch8						
Isolation to system:	Reinforced (double insulation), 264Vac max					

APPENDIX D9 DO4 - FOUR CHANNEL DIGITAL OUTPUT MODULE

D9.1 DESCRIPTION

The Four Channel Digital Output Module provides four logic outputs, which are typically used for control, alarms or events. There are two variants:

- A logic output with 10mA capability, typically used for driving thyristor units or single phase Solid State Relays (SSRs).
- A 24V output with 100mA capability, typically used for driving solenoids, relays, lamp drives, small motors, fans or some three phase SSRs.

The module requires an external power supply of between 18 and 30 volts which may be linked to any number of logic output modules. The current rating of this power supply depends upon the number and type of modules in use and the currents drawn from each digital output.

A suitable power supply is the type 2500P, described in *2500P Module*.

Typical parameters which can be configured include:

- On/Off or Time Proportioning output mode
- High and low output limit.

D9.2 TERMINAL CONNECTIONS

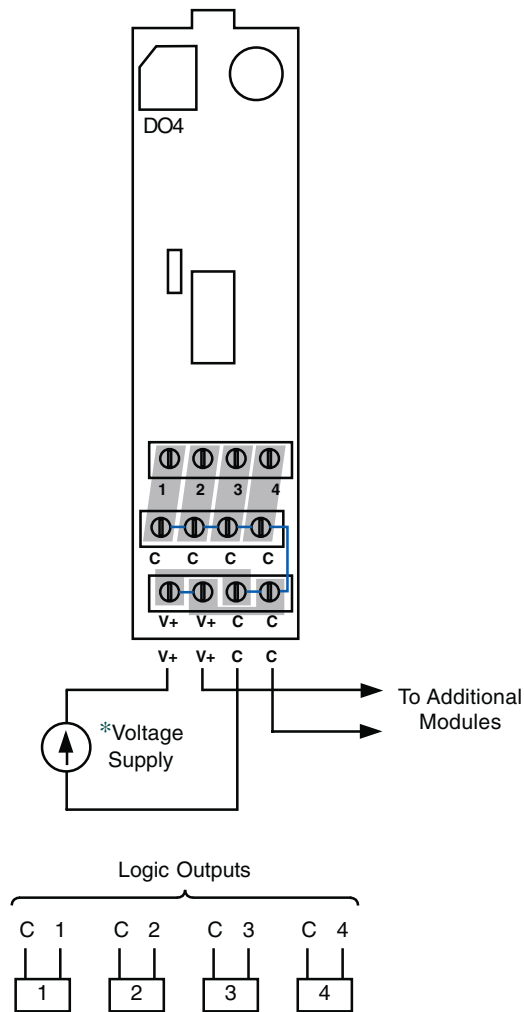

*Note. * - This supply is an external power supply to power plant devices.*

WIRING REDUNDANT MODULES

This module does not currently support redundant wiring operation.

Figure DO4-1 Four Channel Digital Output Module Terminal Connections

D9.3 DIGITAL OUTPUTS

D9.3.1 Isolation Diagram

Transducers can be directly wired into any appropriate channel at the terminals, but introduces safety implications, particularly risk of shock hazard. Electrical isolation minimizes such risks even when equipment goes faulty, and particularly when some transducers have to be run 'live'.

To provide effective operation a very simple isolation strategy is implemented in the form of a barrier separating all I/O channels in any I/O module from the rest of the system. This prevents hazardous voltages on any I/O channel introducing hazards on any wiring on another I/O module, or put at risk the rest of the system. Modules providing isolation channel-to-channel ensure safety and good signal quality on all channels.

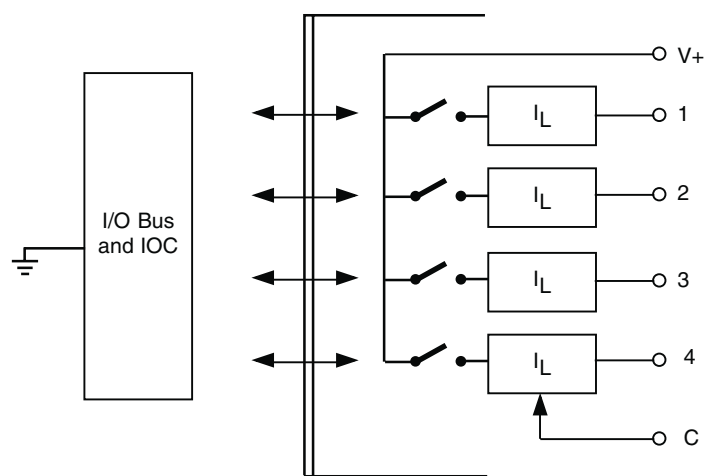

Note. I_L indicates the current-limit mechanism.

Figure DO4-2 Isolation Diagram

D9.3.2 Equivalent Circuits

The equivalent circuits below show the output drive from the Four Channel Digital Output Module for purposes of determining the load conditions.

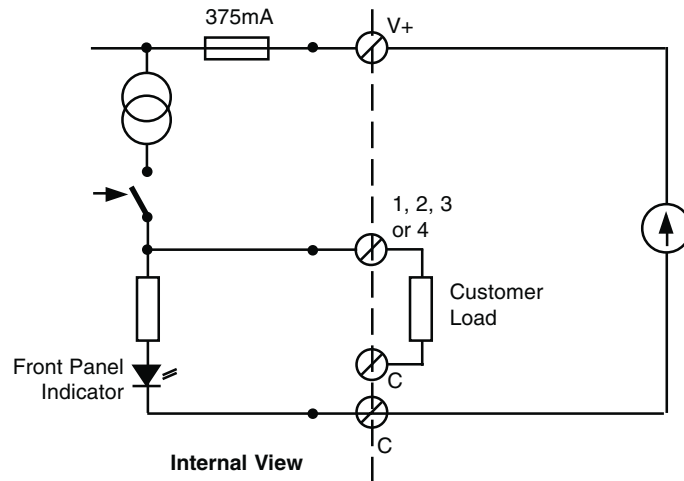

Figure DO4-3 Logic Output Equivalent Circuit

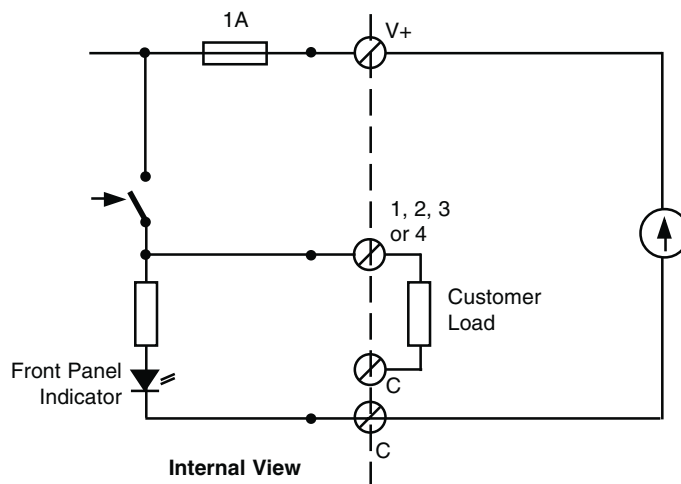

Figure DO4-4 Voltage (24V) Switch Output Equivalent Circuit

D9.4 STATUS INDICATION

The status of the module is shown by five LED indicators as follows:

Notes.

1. *The digital outputs are physically measured at the output terminals. The channel LED, therefore, represents the state at the terminal and not necessarily the drive from the module.*
2. *The operating LED is turned on for 1sec when the module is reset for test purposes.*

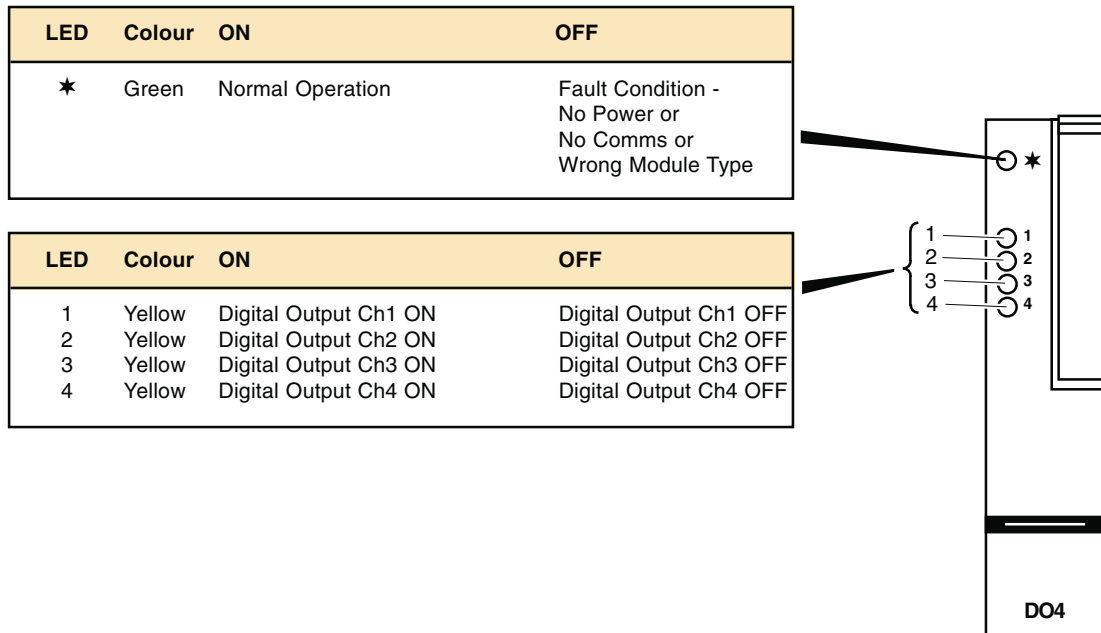

Figure DO4-5 Four Channel Digital Output Module Status Indication

D9.5 SPECIFICATIONS

D9.5.1 DO4 Module

Channel Types: On/Off, TPO, Valve Raise/Lower.

Note. The 24V version is also capable of delivering 100mA with each channel. Thermal protection provides safe operation even with difficult loads.

External Power Channel Specification

Channel Supply (Vcs):	18Vdc to 30Vdc, 24V nom.
Logic 1 Voltage Output:	Vcs - 3V min. (5mA load).
Logic 1 Output (I _L):	±8mA, current limited to <16mA nom.
Off State Leakage:	<0.1mA

24V Channel Specification

Channel Supply (Vcs):	12Vdc to 30Vdc
Logic 1 Voltage Output:	Vcs - 3V min. (not in power limiting).
Logic 1 Current Output:	100mA max current limit (not in power limiting).
Channel Power Limiting:	Output device temperature limiting capable of: >60mA into 100Ω, at Vcs = 24.0V (power limiting test) >20mA driving short-circuit load, 12V < Vcs < 30V

General Specification

Module power consumption:	0.6W max
Isolation channel - channel:	N/A (Channels share common connections)
Isolation to system:	Reinforced (double insulation), 264Vac max

APPENDIX D10 DO8 - EIGHT CHANNEL DIGITAL OUTPUT MODULE

D10.1 DESCRIPTION

The Eight Channel Digital Output Module provides eight high-current 'logic' drive outputs, which are typically used for control and alarm applications.

- A 24V output can switch up to 1A. A 4A self-resetting fuse is fitted in each module to protect this external supply. Typically used to drive small motors, solenoids, lamps, and SSR's.

The channels are isolated as a block from the system, see *Equivalent Circuits* section. If this isolation barrier is to be maintained then an appropriate isolated supply must be used.

- An external supply is required (for load power).

A power supply from the 2500P range is appropriate for 24V applications, described in *2500P module*.

Typical parameters which can be configured include:

- On/Off or Time Proportioning output mode

D10.2 TERMINAL CONNECTIONS

Caution

When fitting a DO8 module to a currently powered system, outputs may turn on momentarily (typically less than 100ms) . Critical installations should disconnect V+ before the module is installed.

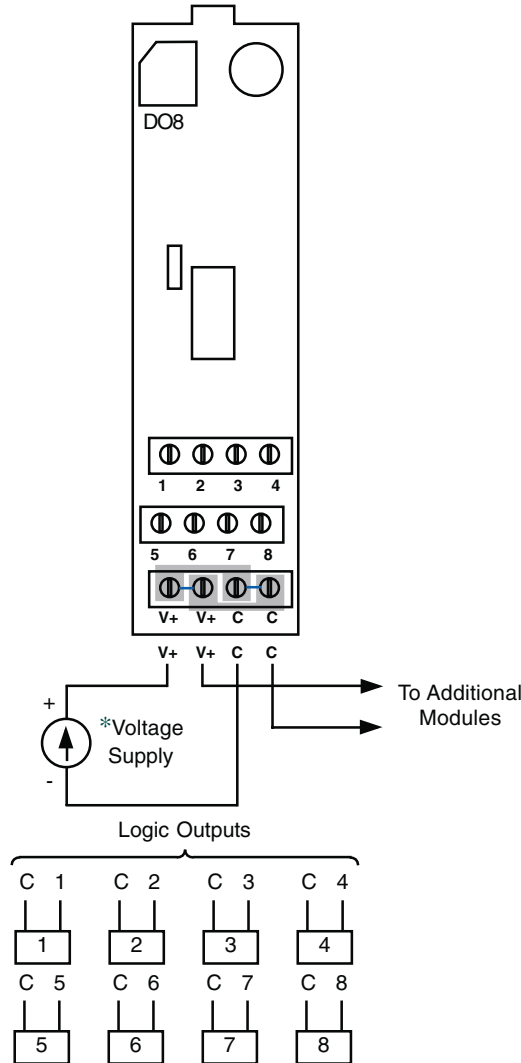

*Note. * - This supply is an external power supply to power plant devices.*

WIRING REDUNDANT MODULES

This module does not currently support redundant wiring operation.

Figure DO8-1 Eight Channel Digital Output Module Terminal Connections

D10.3 DIGITAL OUTPUTS

D10.3.1 Isolation Diagram

Transducers can be directly wired into any appropriate channel at the terminals, but introduces safety implications, particularly risk of shock hazard. Electrical isolation minimizes such risks even when equipment goes faulty, and particularly when some transducers have to be run 'live'.

To provide effective operation a very simple isolation strategy is implemented in the form of a barrier separating all I/O channels in any I/O module from the rest of the system. This prevents hazardous voltages on any I/O channel introducing hazards on any wiring on another I/O module, or put at risk the rest of the system. Modules providing isolation channel-to-channel ensure safety and good signal quality on all channels.

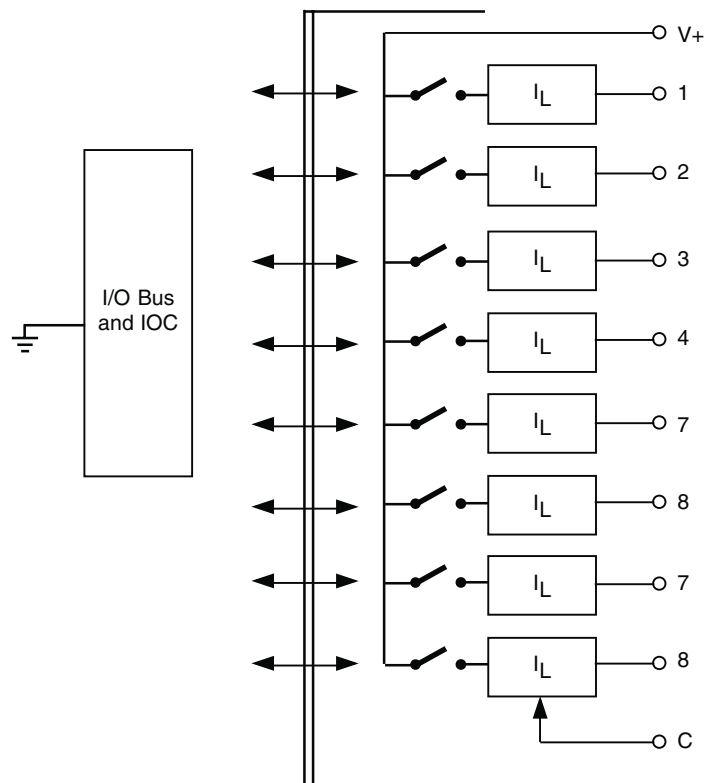

Note. I_L indicates the current-limit mechanism.

Figure DO8-2 Isolation Diagram

D10.3.2 Equivalent Circuits

The equivalent circuits below show the output drive from the Eight Channel Digital Output Module for purposes of determining the load conditions.

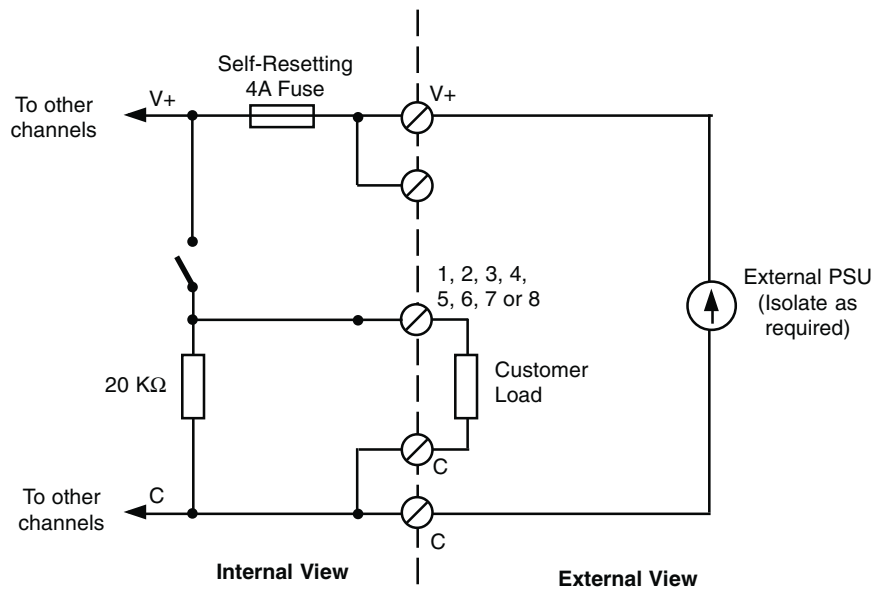

Figure DO8-3 Voltage (24V) Switch Output Equivalent Circuit

D10.4 STATUS INDICATION

The status of the module is shown by nine LED indicators as follows:

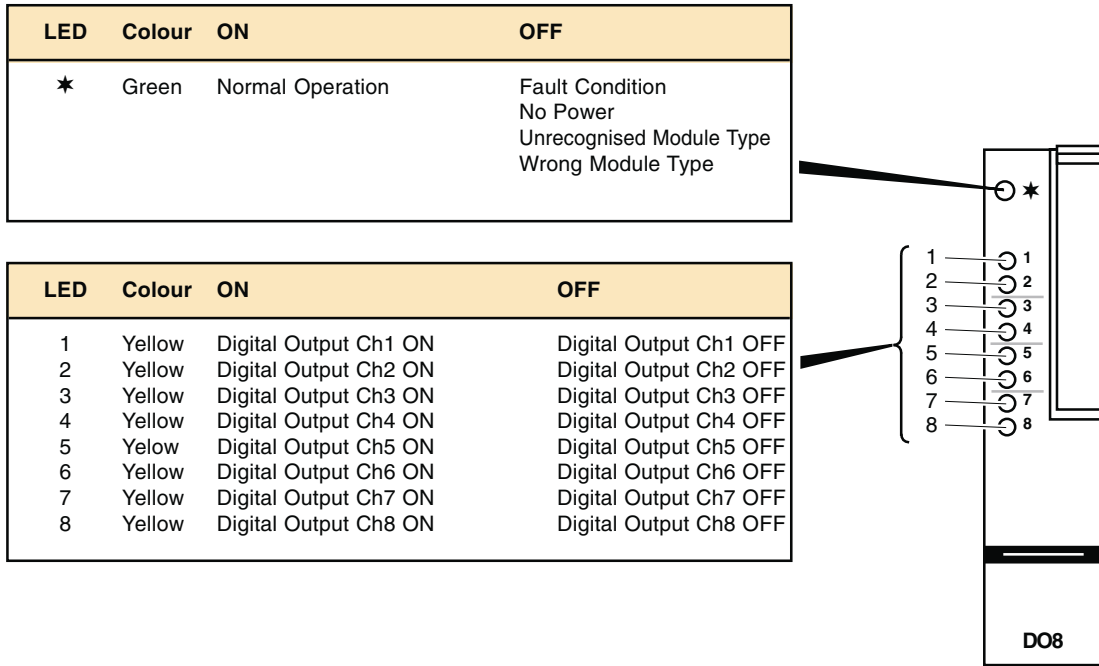

Figure DO8-4 Eight Channel Digital Output Module Status Indication

D10.5 SPECIFICATIONS

D10.5.1 DO8 Module

Channel Types: On/Off, TPO, VP.

External Power Supply Specification

Channel Supply (Vcs):	13.0Vdc to 28.8Vdc
Supply Protection:	Internally limited to 4A, with over-temperature trip. Fault Trip Time, 4ms max. Fault Recovery, automatically reconnects within 150ms after fault is removed.

Note. The fitted PSU must be rated to support the maximum load. The internal 4A limit is to protect large system supplies in case of a fault. The PSU MUST be isolated to maintain channel isolation.

24V Channel Specification

Logic 1 Voltage Output Drop:	<3.0V full load, < 2.0V no load.
Logic 1 Current Output:	1.0A max current limit.
Logic 0 Voltage Output:	<0.1V max.

Note. This shows the ratings for one channel only. The total current over all 8 channels must NOT exceed 4A.

General Specification

Module power consumption:	0.75W max
Isolation channel - channel:	N/A (Channels share common connections)
Isolation to system:	Reinforced (double insulation), 264Vac max

APPENDIX D11 RLY4 - RELAY MODULE

D11.1 DESCRIPTION

The Relay Module provides four relay outputs, one relay with changeover contacts, and three with normally open contacts.

Typical parameters which can be configured include:

- On/Off mode, Time Proportioning mode, Valve Position mode (raise/lower)
- Minimum pulse time for time proportioning outputs

D11.1.1 Snubber Circuits

Each relay is fitted with a 'snubber' (22nF + 100Ω) wired across the contacts. The snubbers are used to prolong contact life and to suppress interference particularly when switching inductive loads such as mechanical contactors and solenoid valves.

Snubbers pass a small current typically 1.0mA at 110V 60Hz and 1.7mA at 240V 50Hz, which may be sufficient to hold in high impedance loads as, for example, found in some relay coils.

Should it be necessary to remove any of the snubbers, refer to [D11.6 Relay Module Snubber Circuits Removal](#).

WARNING

When a relay contact is used in an alarm circuit, ensure that the current passing through the snubber when the relay contact is open does **not** hold in low power electrical loads and thereby interfere with the fail-safe operation of the alarm circuit.

D11.2 TERMINAL CONNECTIONS

Note. The fuses supplied for the Relay modules are 3.15A (T type), 20mm to EN60127.

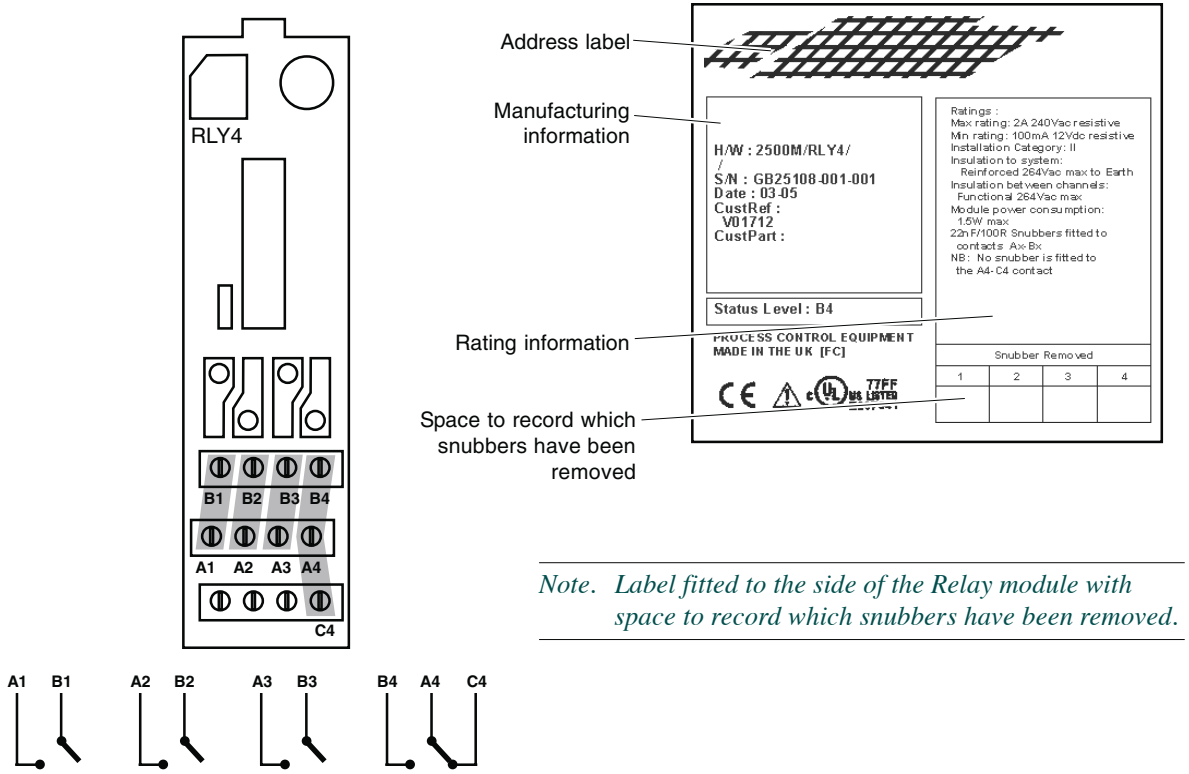

Note. Label fitted to the side of the Relay module with space to record which snubbers have been removed.

Note. Relays shown above in power off state.

WIRING REDUNDANT MODULES

This module does not currently support redundant wiring operation.

Figure RLY4-1 Relay Module Terminal Connections

D11.3 RELAY OUTPUTS

D11.3.1 Isolation Diagram

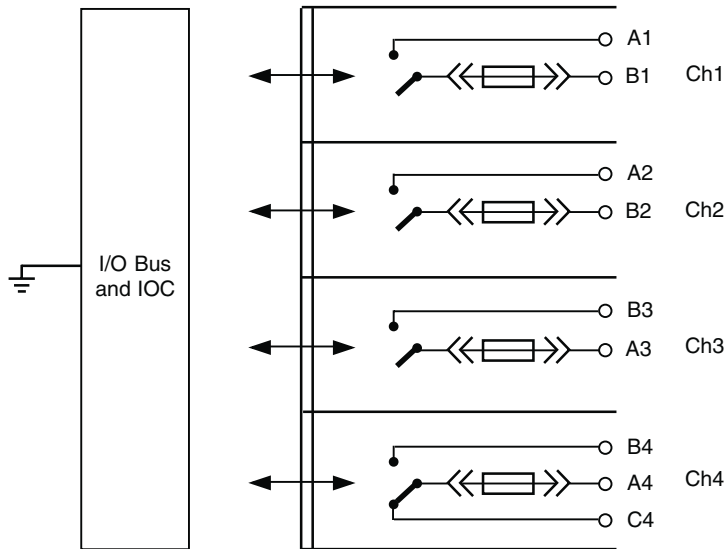

Figure RLY4-2a Isolation Diagram - Fused Option

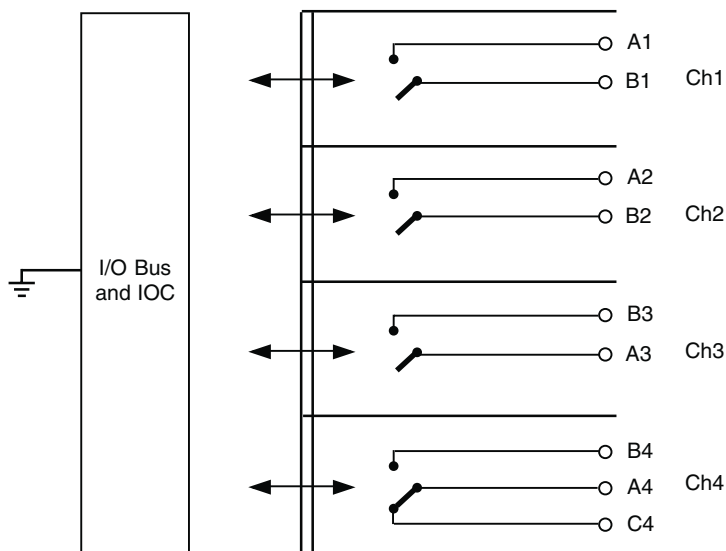

Figure RLY4-2b Isolation Diagram - Unfused Option

D11.4 STATUS INDICATION

The status of the module is shown by five LED indicators as follows:

Note. When the module is reset all LEDs are lit for 1sec for test purposes.

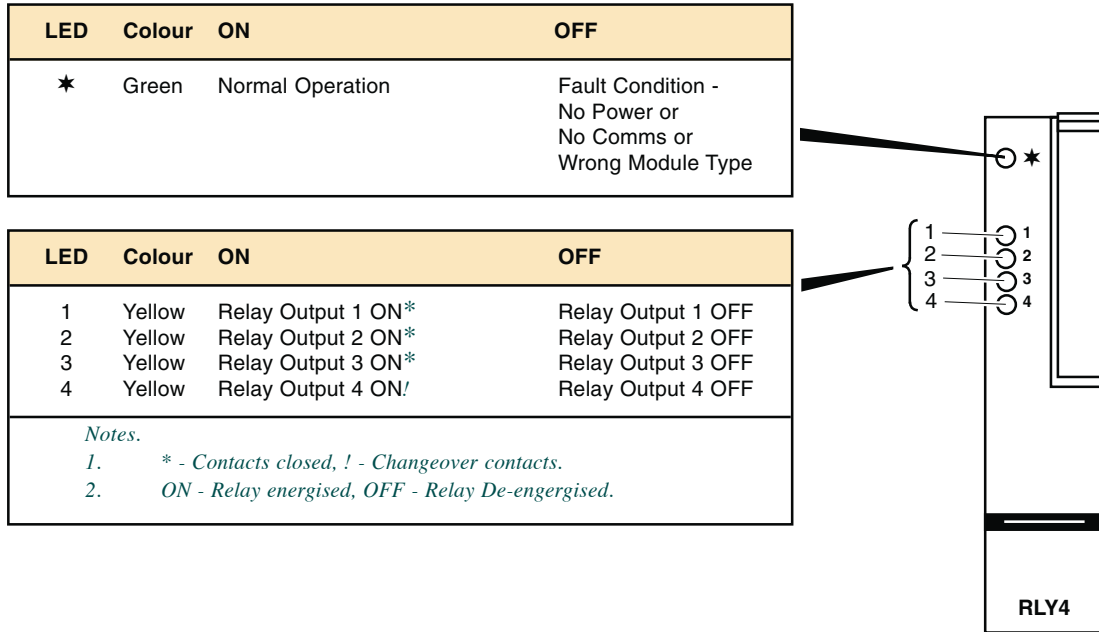

Figure RLY4-3 Relay Module Status Indication

D11.5 SPECIFICATIONS

D11.5.1 RLY4 Module

Channel Types: On/Off, TPO, Valve Raise/Lower.

Channel: 3 N/O (normally open contacts), 1 C/O (changeover contact).

Note. "wetting" power: lower voltages or currents may be switched at reduced contact life.

Channel Specification

Voltage Rating:	<264V rms sine wave, <200Vdc
ac Current:	2A at 0 to 264Vac, resistive load
ac Derating:	Reduce max current rating 10% for load factor of 0.5
dc Current:	2A at <50Vdc
dc Derating:	Max current reduces to 0.5A at 200Vdc
Wetting Voltage:	12V min
Wetting Current:	100mA min
Snubber:	100W + 22nF (see note) across all N/O contacts.

General Specifications

Module power Consumption:	1.5W max
Output Channels 1 to 3 (N/O):	Max switched voltage, 264 Vac rms, 120 Vdc, resistive Min switched voltage, 12 Vdc resistive
Output Channel 4 (Changeover):	Max switched voltage, 264 Vac rms, 120 Vdc, resistive Min switched voltage, 12 Vdc
Output Channels 1 to 3 (N/O):	Max switched current, 2A ac rms resistive Min switched current, 100 mA ac rms or dc resistive
Output Channel 4 (Changeover):	Max switched current, 2A ac rms Min switched current, 100 mA ac rms or dc

Note. The Snubber circuit may be removed by cutting the resistors off the board.

Isolation channel - channel:	Functional (basic insulation), 264Vac max
Isolation to system:	Reinforced (double insulation), 264Vac max

D11.6 RELAY MODULE SNUBBER CIRCUITS REMOVAL

Each Relay is fitted with a ‘snubber’ (22nF + 100Ω) wired across the contacts. The snubbers are used to prolong contact life and to suppress interference particularly when switching inductive loads such as mechanical contactors and solenoid valves.

Snubbers pass a small current typically 1.0mA at 110V 60Hz and 1.7mA at 240V 50Hz, which may be sufficient to hold in high impedance loads as, for example, found in some relay coils.

If this is found to be the case, the snubber can be removed by cutting all or any one of the snubber resistors from the printed circuit board.

D11.6.1 Instructions

1. Remove the rear cover from the module:

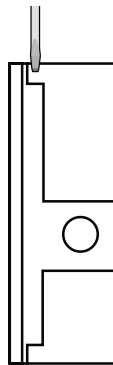

- i. Open the module retaining lever.
- ii. Gently ease the rear cover out of the module by inserting a small screwdriver in the slots at the top and bottom of the cover.
- iii. Gently ease the rear cover over the module retaining catch. It may be necessary to use the screwdriver in positions - to gently lever the cover over the catch.

2. Remove the printed circuit board from module case as follows:

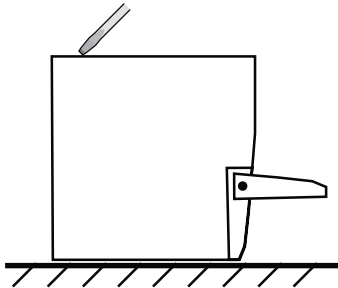

- i. Invert the module and support it securely on a bench or table top.
- ii. Squeeze the sides of the module so that the edge of the module bows outwards.
- iii. Very carefully insert a screwdriver into the slot in the edge of the module.

Caution

Take care that the screwdriver does not slip which may cause injury.

3. Remove the snubber resistors:

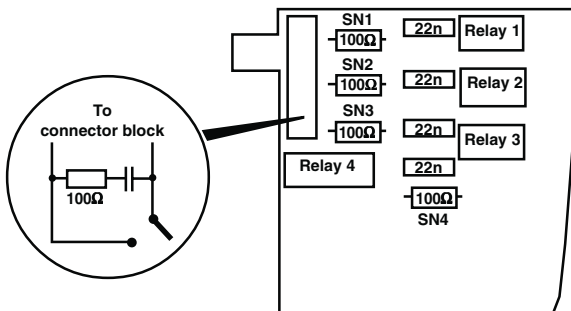

- i. Using a suitable pair of wire cutters, snip out and remove the 100Ω resistor to remove the required snubber circuit.
- ii. Record the removal of the snubber resistor on the side of the module in the place provided. This will provide easy identification of which snubbers have been removed in the event that the module needs to be replaced.

APPENDIX D12 F12 - TWO CHANNEL FREQUENCY INPUT MODULE

D12.1 DESCRIPTION

This module is used for data gathering and signal conditioning from a range of plant sensors. It has internal supplies that provide loop or wetting current or can be used to power sensors.

These include:

- Magnetic
- Voltage
- Current
- Contact

It consists of two isolated input channels.

Typical parameters which can be configured or changed include:

- Input type: Magnetic, Voltage, Current, Contact
- Supply output voltage
- Logic threshold, Voltage or Current
- Contact Debounce

D12.2 TERMINAL CONNECTIONS

Each Channel operates independently, therefore the Link configuration for each Channel must be set accordingly.

Caution

Do not install more than 8 FI2 modules in a single Base Unit if the channel output load at 24V is more than 5mA per channel. If more loads are required than this restriction permits, an external power supply must be used.

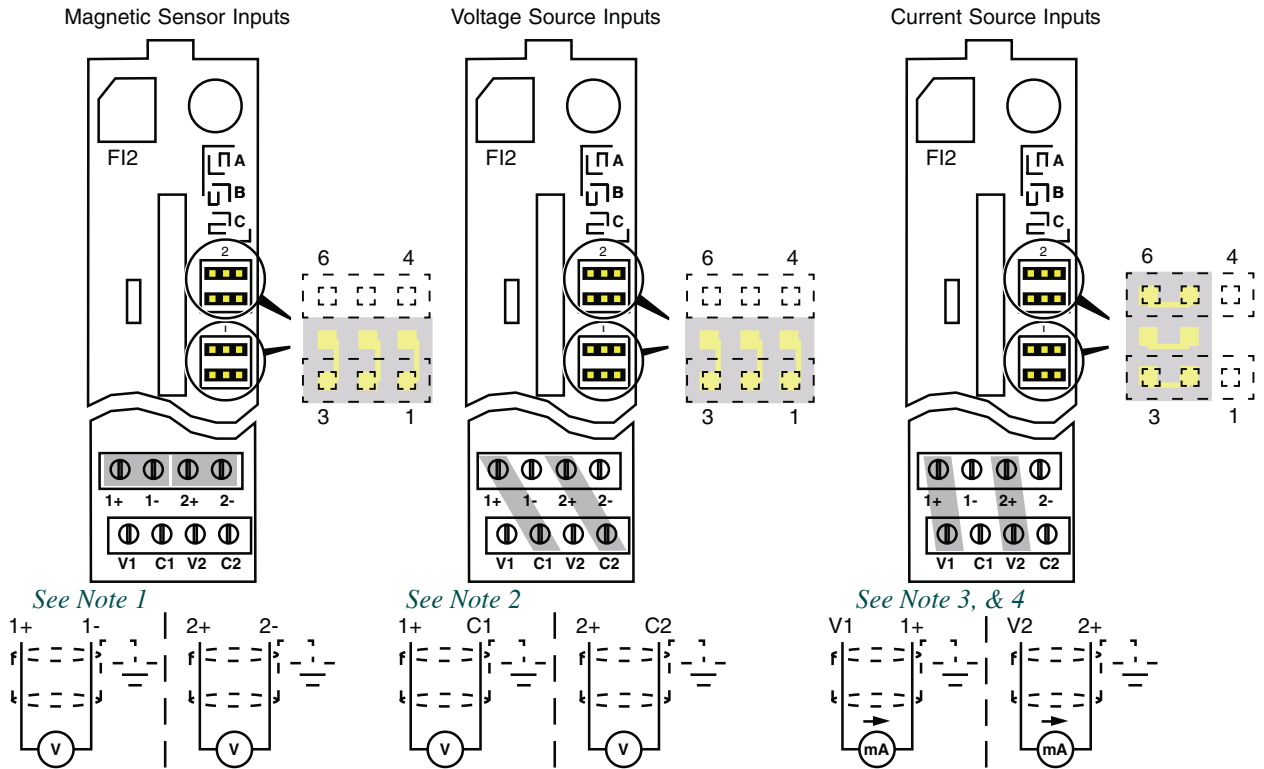

Notes.

- 1 Links must be set to Voltage (position C), and corresponding FI_UIO block InType field must be set to Magnetic. The Threshold is internally configured.
- 2 Links must be set to Voltage (position C), and corresponding FI_UIO block InType field set to V. If using the output supply to power the sensor, set the output supply voltage as required, 8V, 12V, or 24V.
- 3 Links must be set to Current (position B) to select the internal current burden resistor, and the corresponding FI_UIO block InType field set to mA. When the internal burden resistor is selected the transducer must not exceed 12V. The output supply must be set to the requirements of the transducer, 8V, or 12V.
- 4 The Terminal Unit includes an internal 1KΩ burden resistor. If using an external current burden resistor, connect between 1+ and C1 (channel 1) and 2+ and C2 (channel 2). Links must be set to Voltage (position C), and the InType field in the FI_UIO block set to Volts (V). The Threshold must be set to the midpoint between the peak to peak voltage across the burden. The output supply must be set to the requirements of the transducer, 8V, 12V, or 24V.

Figure FI2-1a Two Channel Frequency Input Terminal Connections

D12.2 Terminal Connections (Cont.)

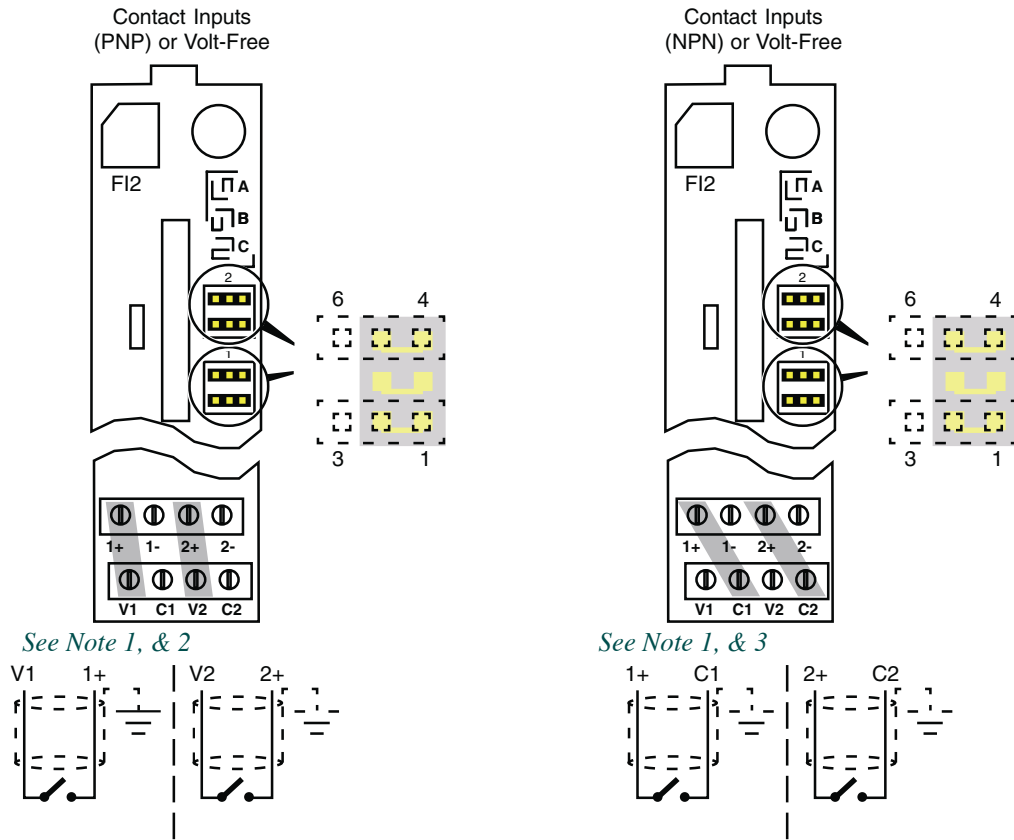

Notes.

- 1 Links must be set to Contact (position A), and corresponding FI_UIO block InType field set to V. For minimal temperature rise, an output supply of 8V is recommended.
- 2 Threshold must be set to 75% of the output supply Volts, i.e. 6V, 9V, 18V.
- 3 Threshold must be set to 25% of the output supply Volts, i.e. 2V, 3V, 6V.

WIRING REDUNDANT MODULES

This module does support redundant wiring operation , see 2500M I/O Module Redundant Configuration Handbook.

Figure FI2-1b Two Channel Frequency Input Terminal Connections

D12.3 APPLICATION DETAILS

To prevent inappropriate noise and achieve the recommended EMC installation requirements all signal and channel power supply connections MUST use a screened cable. It is recommended that the screen is braided and connected to the Base Unit, but NOT connected to the Earth at the sensor, as this will create a ground loop.

Note It is recommended that sensor cabling does not exceed 30m, as high energy surges applied to the module terminals, as defined in IEC61000-4-5, can be detected by the input circuit.

Measurement errors caused by noise interference and channel cross talk can be reduced by setting the Threshold values greater than 1V or 1mA assuming this is compatible with the signal being measured.

When configuring the strategy, specific issues for each application must be addressed accordingly. However, all configurations can apply a Debounce value of 0ms (if not required), 5ms, 10ms, 20ms, or 50ms, with the algorithm ensuring that pulse edges closer than the set time, are excluded.

Caution

An **OverRange** warning is not displayed for signals **approaching** the maximum frequency allowed by the Debounce algorithm. Control loops based on a frequency PV are NOT recommended when Debounce is applied without provision for protecting against the consequences of the frequency passing this upper limit.

When the Links are set in the Voltage (position C) or Current (position B) position, to achieve good pulse detection, and help prevent inappropriate detection of noise spikes and best repeatability, the Threshold must be set, as close as possible to the midpoint between the peak to peak values of the Input. It may be necessary to disable the Sensor Break and Sensor Short Circuit detection via the Options.SBreak and Options.SCct fields in the associated FI_UIO block to prevent inappropriate alarms. The Sensor Break alarm is set if the Input value falls below 0.05V or 0.05mA. The Sensor Short circuit alarms is set if the Input value rises above 91% of the output supply Volts (Volts or milli-amps).

A NAMUR Input on a module configured in the Current (position B), must be set to 8V output supply, and the threshold must be set to 1.65mA. Sensor Break and Sensor Short circuit detection can be enabled, if required.

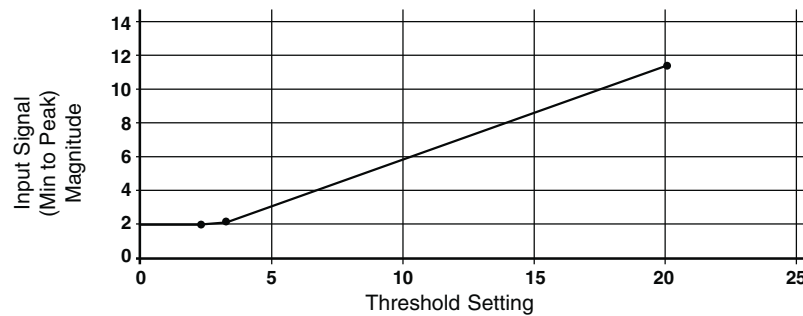

Note To allow for Hysteresis and Threshold accuracy with temperatures and between modules that have been swapped, the input signal MUST have sufficient amplitude. Use this graph as a guide to the size of signal for a given Threshold setting.

When the Links are set in the Contact Inputs (position A) position, the 5k biasing resistors are connected that provides a wetting current. If more wetting current is required, additional resistors can be fitted to the Terminal Unit, or an external biasing supply can be connected, and the threshold configured for either accordingly. Sensor Break and Sensor Short circuit detection must be disabled via the Options.SBreak and Options.SCct fields in the associated FI_UIO block.

D12.4 FREQUENCY INPUTS

D12.4.1 Isolation Diagram

To provide effective operation a very simple isolation strategy is implemented in the form of a barrier separating all I/O channels in any I/O module from the rest of the system. This prevents hazardous voltages on any I/O channel introducing hazards on any wiring on another I/O module, or put at risk the rest of the system. Modules providing isolation channel-to-channel ensure safety and good signal quality on all channels.

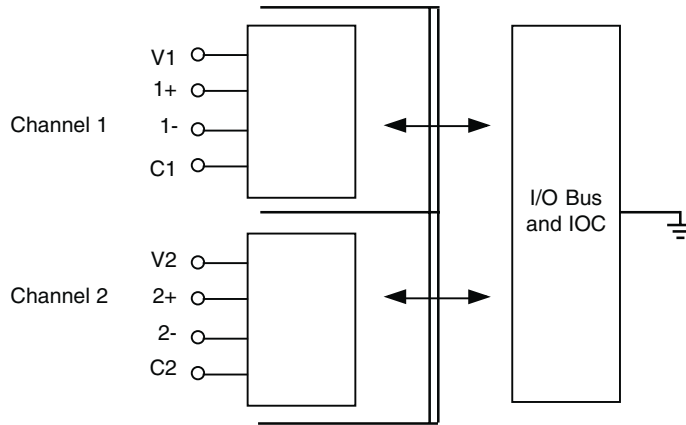

Figure F12-2 Isolation Diagram

D12.4.2 Equivalent Circuits

The equivalent circuits below show details of frequency inputs.

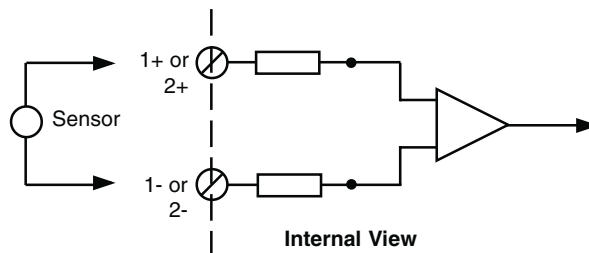

Figure F12-3a Magnetic Input

D12.4 FREQUENCY INPUT EQUIVALENT CIRCUITS (Cont.)

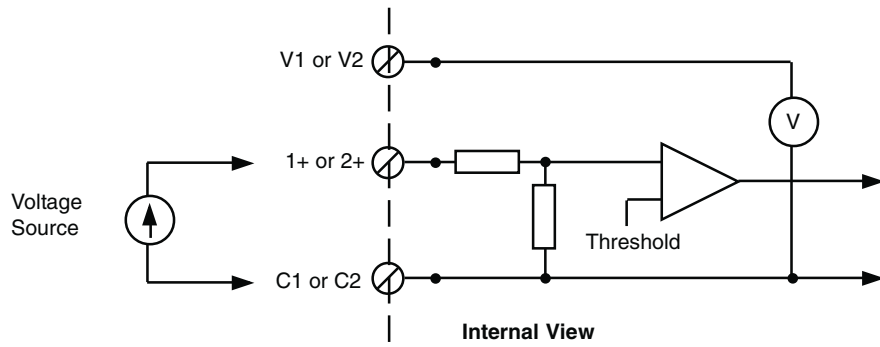

Figure F12-4b Voltage Input

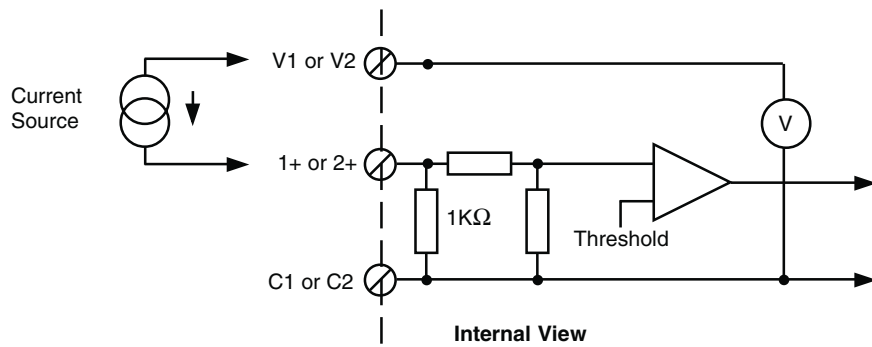

Figure F12-5 Current Input

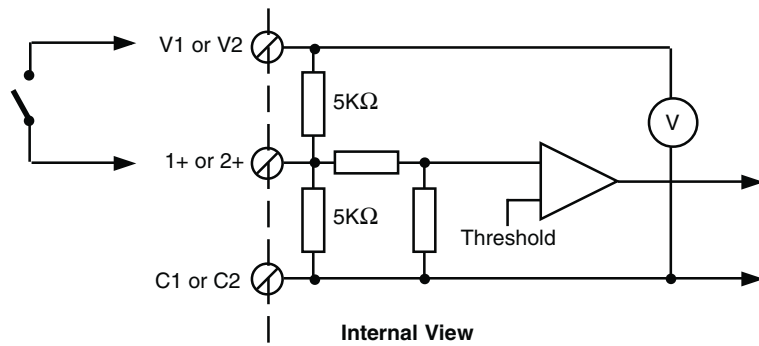

Figure F12-6 Contact Inputs (PNP) or Volt-Free

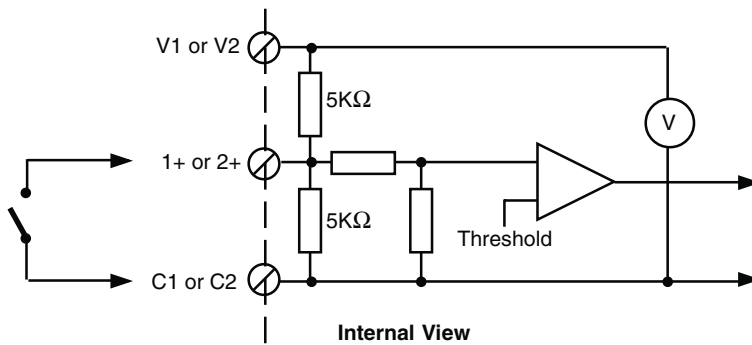
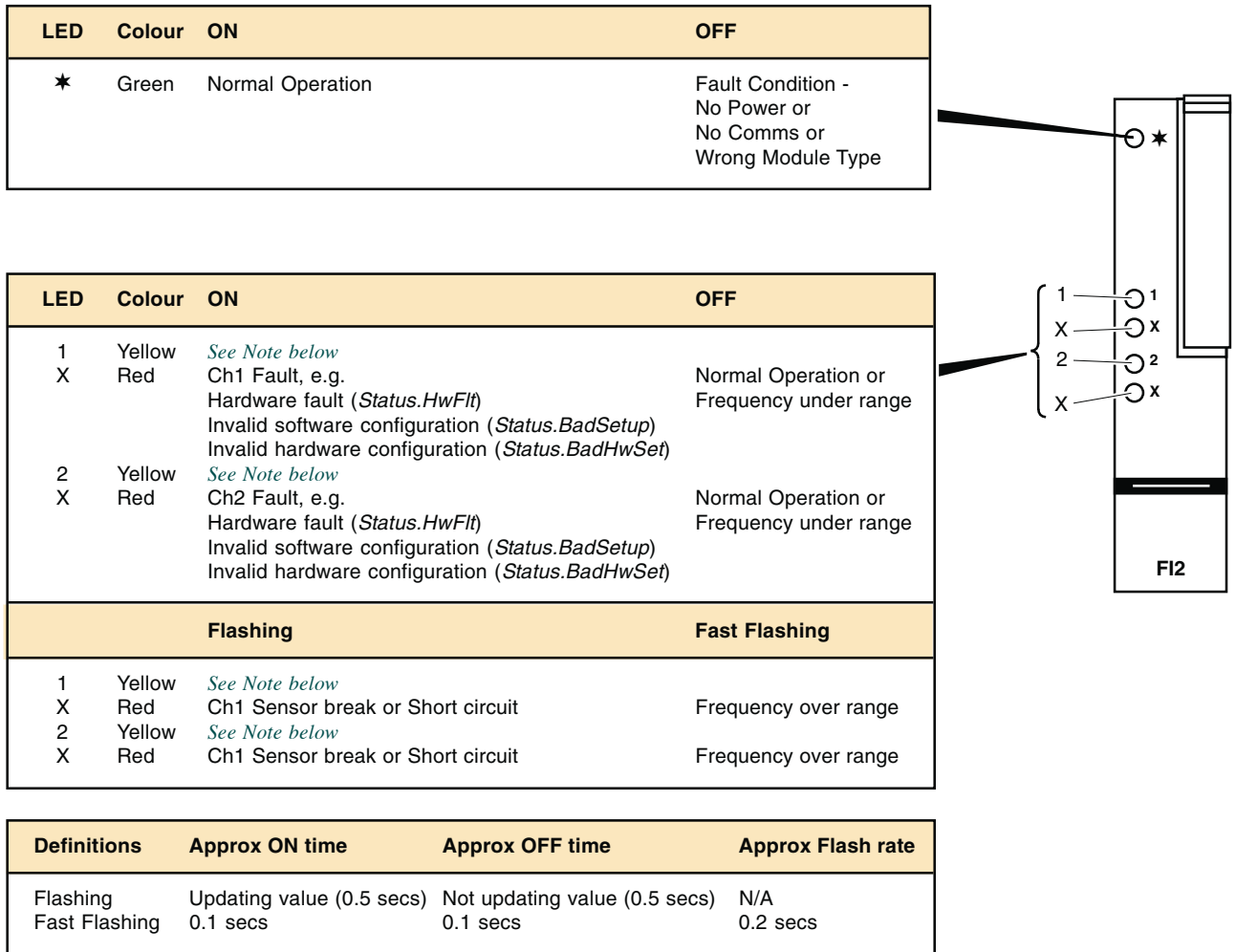

Figure F12-7 Contact Inputs (NPN) or Volt-Free

D12.5 STATUS INDICATION

The status of the module is shown by the LED indicators as follows:



Note. LED 1 and LED 2 show Channel 1 and Channel 2 activity respectively.

Figure F12-8 Two Channel Frequency Input Status Indication

D12.6 FAULT DETECTION

Detected faults can be defined as Field, Setup, or Hardware faults, but any reaction will depend on the Input configuration of the associated FI_UIO block. These faults are indicated via the LEDs on the Module, and the *Status* and *Alarms* bits of the corresponding FI_UIO block.

D12.6.1 Fault Diagnostics

To locate the cause of a fault, inspect the *Status* and *Alarms* bits of the associated FI_UIO block. These bits indicate the source of the fault, i.e. Hardware (*Status.HwFlt*), or invalid configuration (*Status.BadSetup*).

Block Field	Description/To Resolve
Status.Missing	The associated MOD_UIO block has not been found, caused by an incorrectly configured Strategy, i.e. the MOD_UIO block does not exist in the Strategy. This will set the <i>Alarms.ModBlock</i> field TRUE. To resolve, ensure the Strategy contains the required MOD_UIO block.
Status.BadType	The Channel configured in the block, does not correspond to the module. To resolve, ensure the block and the module correspond.
Status.Ranging	The Input value is not measurable by the hardware, but a fault is not detected, i.e. the Input is currently being ranged or configured.
Status.BadSetup	An invalid setup is detected, caused by an incorrect <i>LR_in</i> or <i>HR_in</i> field configuration. This will set the <i>Alarms.OutRange</i> field TRUE. To resolve, ensure <i>LR_in</i> or <i>HR_in</i> fields correspond to the range used by the installed hardware.
Status.HwFlt	A fault in the output supply is detected, generally caused by output supply overload. This will set the <i>Alarms.Hardware</i> field TRUE.
Status.NotAuto	The module is not operating in Automatic mode. This will set the <i>Alarms.NotAuto</i> field TRUE.
Status.OvrRng	The Input value is greater than the measurement circuit range is detected, generally caused by an input value greater than 40KHz, but less than 80KHz.
Status.UnderRng	The Input value is less than the measurement circuit range is detected, generally caused by an input value less than 10Hz, for a Magnetic Sensor configuration, and less than 0.01Hz for the Voltage, Current, or Contact configuration.
Status.OpenCct	An Open circuit fault in the Logic Sensor is detected. This will set the <i>Alarms.CctFault</i> field TRUE. For details, see Terminal Connections .
Status.ShortCct	An Short circuit fault in the Logic Sensor is detected. This will set the <i>Alarms.CctFault</i> field TRUE. For details, see Terminal Connections .
Status.BadHwSet	The hardware configuration does not correspond to the Input Type configured in the FI_UIO block. To resolve, ensure the Link configuration, see Terminal Connections , on the Terminal Unit corresponds to the <i>InType</i> field of the FI_UIO block.
Status.CutOff	A measured frequency value below the low threshold value (<i>CutOff</i>) is detected. This will set the <i>Alarms.CutOff</i> field TRUE, with the measured frequency value adopting the value defined in the <i>Default</i> field.
Status.BadTask	Task Rate configured in the block does not correspond to the Task Rate of the module. This also asserts the <i>Alarms.Hardware</i> field TRUE. To resolve, the <i>Task rate</i> of the module and the <i>Task rate</i> in the block MUST be configured to the slow task (Task 3 - 110ms).

Table D12.1 Fault Indication

D12.7 SPECIFICATIONS

Values given with respect to V_s , where V_s is an externally supplied voltage, nominally 24V. Plant Side Interface.

D12.7.1 F12 Module

Input Types: Magnetic Sensor, Voltage, Current, and Contact.

Channel Specifications

Frequency measurement:

Range:	Logic, 0.01Hz - 40kHz, debounce off Magnetic, 10Hz - 40 kHz
Resolution:	<60 ppm of reading for square wave input
Accuracy:	± 100 ppm, reference. ± 160 ppm, overall. $\pm 0.05\%$ over 5 years, drift

Pulse counting:

Range:	Logic, Vdc - 40kHz, debounce off Magnetic, 10Hz - 40 kHz
--------	---

Debounce applied (Voltage, Current, Contact):

Setting:	Maximum Frequency
5ms	100Hz
10ms	50Hz
20ms	25Hz
50ms	10Hz
Resolution:	<600 ppm of reading for square wave input

Magnetic Sensor Input Specification

Input Range:	10mV to 80V p-p
Absolute Maximum Input:	± 100 V
Input Impedance:	>30K Ω

D12.7.2 F12 DC Module (Cont.)

Logic Input Specification

	Minimum Pulse Width:	1.2 μ S, debounce off (0ms).
Voltage:		
	Input Range:	0 - 20V
	Absolute Maximum Input:	50V
	Input Impedance:	>30K Ω
	Threshold:	0 - 20V, \pm 0.2V hysteresis, \pm 0.4V or \pm 7% , whichever is the greater
	Sensor Break Level:	50mV - 310mV (\pm 10%), Active for Threshold settings between 200mV and 7.4V
	Sensor Short Circuit:	N/A
Current:		
	Input Range:	0 - 20mA
	Absolute Maximum Input:	30mA
	Input Impedance:	1K Ω
	Threshold:	0 - 20mA, \pm 0.2mA hysteresis, \pm 0.4mA or \pm 7% , whichever is the greater
	Sensor Break Level:	0.05mA - 0.31mA (\pm 10%)
	Sensor Short Circuit:	100R - 350R
		} Active for Threshold settings between 0.2mA and 7.4mA
Contact:		
	Input Range:	N/A
	Absolute Maximum Input:	N/A
	Input Impedance:	5K Ω
	Threshold:	0 - 20V, \pm 0.2V hysteresis, \pm 0.4V or \pm 7% , whichever is the greater

Output Specifications

Voltage:	Selectable, 8, 12 or 24 Vdc - 10mA
Maximum current:	25mA
Accuracy:	\pm 20%
Voltage drop:	1V @ 25mA

Note The module has current limit protection. Short circuit of the output will cause temporary failure of pulse input circuit only.

General Specifications

Module power consumption:	3.6W max
Isolation channel - channel:	Functional (basic insulation), 100Vac max
Isolation to system:	Reinforced (double insulation), 264Vac max

D12.8 CONFIGURE CHANNEL VOLTAGE SETTING

The Terminal Unit is fitted with a break-out box containing dis-connects for isolating the power supply outputs and input signals. It is also fitted with burden, and pull up resistors for the channel inputs and are configured using the links, see [Instructions](#) section.

Note The links are only accessible when the module is removed.

D12.8.1 Instructions

1. Remove the module from the Terminal Unit.

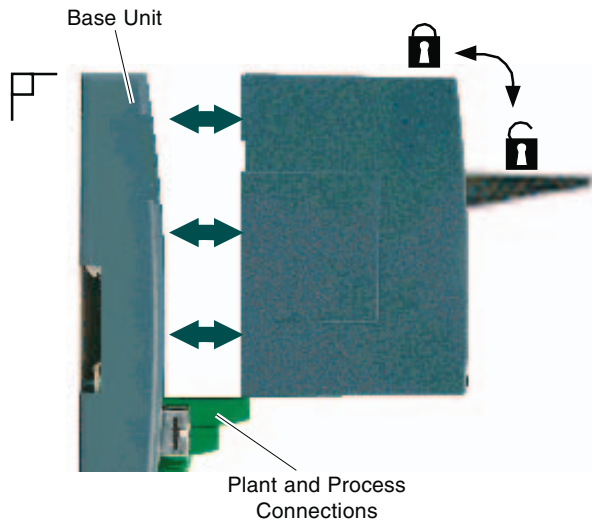

- i Modules are locked into position using the Retaining lever on the face of the module.
- ii The module must be fitted and removed with the Retaining lever in the open (🔓) position, as shown in this side view.
- iii Once fitted the lever must be closed (🔒) to securely lock the module in place.

2. Set the 6-gang Link for each channel, as required, see [Terminal Connections](#).
3. Replace the module, see above.

Intentionally left blank

APPENDIX D13 ZI - ZIRCONIA INPUT MODULE

D13.1 DESCRIPTION

The Zirconia input module is used to measure analogue signals from a range of plant sensors.

These include:

- Thermocouples
- High Impedance (Zirconia)

The Zirconia analogue input module consists of two input channels, isolated from each other and isolated from the system electronics. It is primarily used to measure High Impedance analogue signals from a Zirconia probe plant sensor on Channel 2, although thermocouple inputs can still be measured on Channel 1. The thermocouple inputs Cold Junction Temperature is measured by a RTD sensor fitted to the Terminal Unit.

Typical parameters which can be configured or changed include:

- Input Type
- Range
- Input Filter Time Constant
- Sensor Break Action
- User Calibration. This allows you to offset the 'permanent' factory calibration to:
 - a. Calibrate the controller to your reference standards
 - b. Match the calibration of the controller to that of a particular transducer or sensor
 - c. Calibrate the controller to suit the characteristics of a particular installation

D13.2 TERMINAL CONNECTIONS

Each Channel operates independently.

High impedance input
(Zirconia probe)

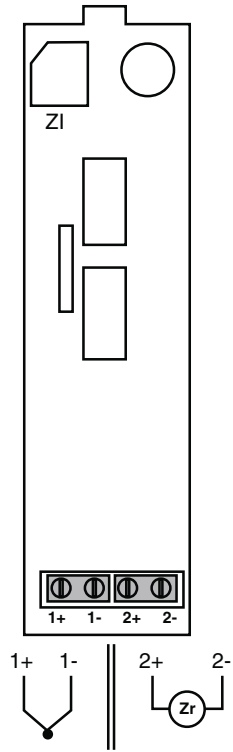

Figure ZI-1 Two Channel Zirconia Input Terminal Connections

D13.3 APPLICATION DETAILS

This module is used to control temperature of the process on one channel (loop) and carbon potential on the other. The module, in conjunction with the strategy, generates temperature and carbon potential profiles synchronised to a common timebase.

Channel 1 is dedicated for use with a thermocouple input, and supports Cold Junction Compensation and linearisations, and output (PV) temperature. The Thermocouple input, Channel 1, automatically scans for the mV input and the Cold Junction Compensation sensor, and can be set for fixed gain. The counts are internally calculated and calibration-compensated to a mV (milli-volt) value. The Pt100 linearisation is then applied to get the Cold Junction Temperature.

However, the primary use of this module is for the Zirconia probe, connected via Channel 2 only. This offers the high-impedance low leakage 2V range used for source-impedance measurement (probe health monitor) on the Zirconia probe channel. Channel 2 outputs a voltage measurement allowing a simple offset and scaling; both supporting PV filter options.

Note To ensure good practice and comply with EMC regulations, it is advised that the Zirconia Probe is connected to Channel 2 of the module using a maximum length of 30m screened cable.

D13.3.1 Temperature Control

The sensor input of the temperature channel (loop) may come from the Zirconia Probe but it is common for a separate thermocouple to be used. The correct configuration of the strategy can control a heating output that can be connected to gas burners or thyristors to control electrical heating elements. In some applications a cooling output may also be connected to a circulation fan or exhaust damper.

D13.3.2 Carbon Potential Control

The Zirconia probe generates a milli-volt (mV) signal based on the ratio of oxygen concentrations on the reference side of the Probe (outside the furnace) to the amount of oxygen in the furnace. The temperature and carbon potential milli-volt values (signals) read into the related block are used to calculate the actual percentage of carbon in the furnace.

D13.3.3 Soot Alarm

In addition to other alarms which may be detected, an alarm can be raised when the atmospheric conditions are such that carbon will be deposited as soot on all surfaces inside the furnace.

D13.3.4 Probe Cleaning

A Probe clean and recovery strategy can be configured to occur between batches or manually requested. A short blast of compressed air is used to remove any soot and other particles that may have accumulated on the probe. Once the cleaning has been completed, the time taken for the probe to recover is measured. If the recovery time is too long this indicates that the probe is ageing and replacement or refurbishment is due. During the cleaning and recovery cycle, the %C reading is frozen thereby ensuring continuous furnace operation.

D13.3.5 Endothermic Gas Correction

A gas analyser may be used to determine the CO or H₂ concentration of the endothermic gas. If a 4-20mA output is available from the analyser, it can be connected to the module and used to display the calculated % carbon reading. Alternatively, this value can be entered manually via the *GasRef.CO_Local* and *GasRef.H2_Local* fields.

D13.4 ANALOGUE INPUTS

D13.4.1 Isolation Diagram

Transducers can be directly wired into any appropriate channel at the terminals, but this flexibility introduces safety implications, particularly risk of shock hazard. Electrical isolation minimizes such risks even when equipment goes faulty, and particularly when some transducers have to be run 'live'.

To provide effective operation a very simple isolation strategy is implemented in the form of a barrier separating all I/O channels in any I/O module from the rest of the system. This prevents hazardous voltages on any I/O channel introducing hazards on any wiring on another I/O module, or put at risk the rest of the system. Modules providing isolation channel-to-channel ensure safety and good signal quality on all channels.

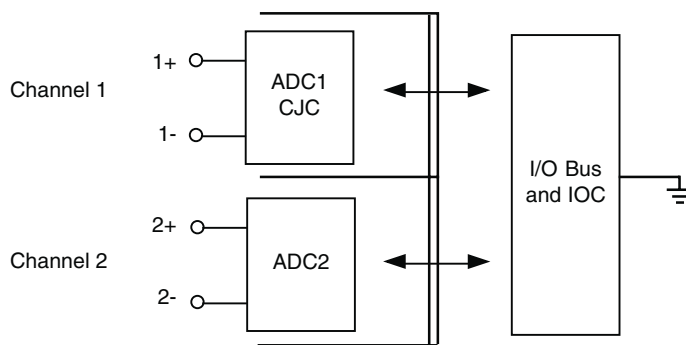

Figure ZI-2 Isolation Diagram

D12.4.2 Equivalent Circuits

The equivalent circuits below show details of analogue inputs.

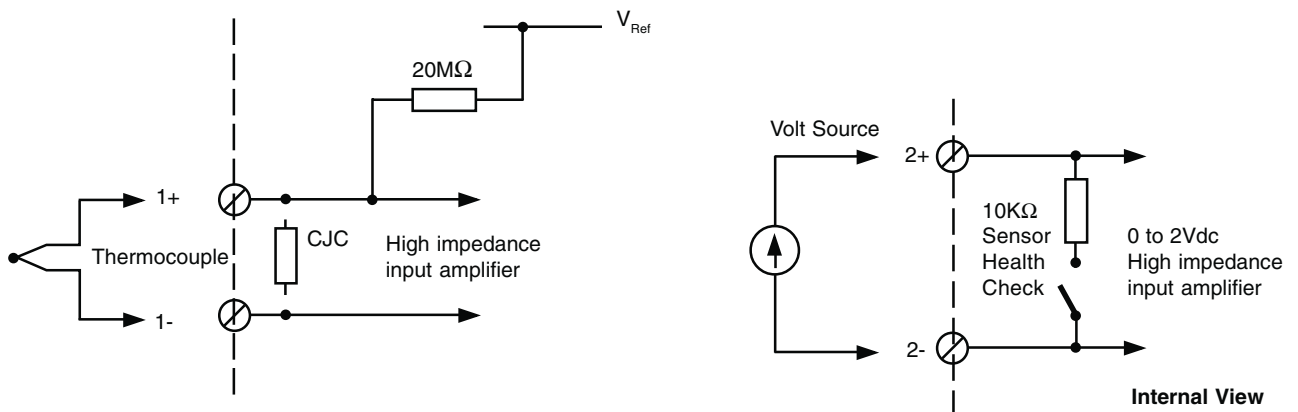

Figure ZI-3 Voltage Input

D13.5 STATUS INDICATION

The status of the module is shown by the LED indicators as follows:

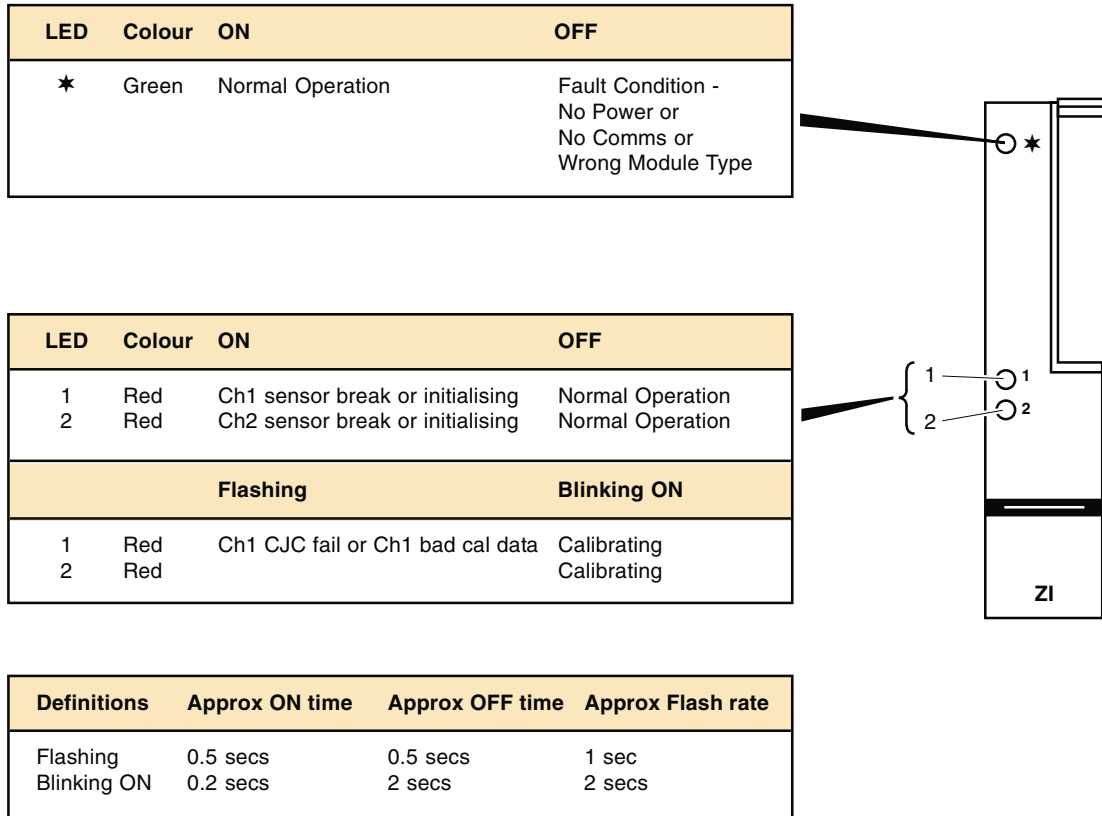

Figure ZI-4 Two Channel Zirconia Input Status Indication

D13.6 FAULT DETECTION

Detected faults can be defined as Field, Setup, or Hardware faults, but any reaction will depend on the Input configuration of the associated **Zirconia** block. These faults are indicated via the LEDs on the Module, and the *Status* and *Alarms* bits of the corresponding **Zirconia** block.

D13.6.1 Fault Diagnostics

To locate the cause of a fault, inspect the *Fields* and related *Alarms* bits of the associated block. These bits indicate the source of the fault, i.e. Hardware (*ProbeSt*), or invalid configuration (*Alarms.PrbImpHi*).

Block Field	Description/To Resolve
ProbeSt	The Probe Input value is not measurable by the hardware, possibly caused by a Probe failure. This will set the <i>Alarms.ProbeSt</i> field TRUE.
TempSt	The Probe Temperature Input value has failed, possibly caused by a Probe failure. This will set the <i>Alarms.TempSt</i> field TRUE.
CarbPotSt	The Carbon Potential value is not measurable by the hardware, possibly caused if the furnace temperature is below the configured minimum calculation temperature value. To resolve, wait until the furnace to acheive the configured minimum calculation temperature value, <i>MinCalcT</i> .
DewPntSt	The Dewpoint value is not measurable by the hardware, possibly caused if the furnace temperature is below the configured minimum calculation temperature value. To resolve, wait until the furnace to acheive the configured minimum calculation temperature value, <i>MinCalcT</i> .
OxygenSt	The Oxygen value is not measurable by the hardware, possibly caused if the furnace temperature is below the configured minimum calculation temperature value. To resolve, wait until the furnace to acheive the configured minimum calculation temperature value, <i>MinCalcT</i> .
SootWrn	The Probe has detected atmospheric conditions that will cause the deposit of soot on all surfaces inside the furnace. This will set the <i>Alarms.SootWrn</i> field TRUE. To resolve, launch the probe clean sequence and ensure the Probe clean sequence completes successfully.
ClnRcvWn	The performance of the probe is degrading, by failing to obtain 95% of the original value in the permitted time, possibly caused by the natural usage. This will set the <i>Alarms.ClnRcvWn</i> field TRUE. To resolve, launch the probe clean sequence and ensure it completes successfully. If alarms continues, replace the probe.
LastClnmV	The probe clean sequence failed, possibly caused by a fault in the probe. This will set the <i>Alarms.ClnRcvWn</i> field TRUE.
CO_RemSt	The Remote CO Gas value is not measurable by the hardware, possibly caused by a Probe failure. This will set the <i>Alarms.CO_Remte</i> field TRUE.
H2_RemSt	The Remote H2 Gas value is not measurable by the hardware, possibly caused by a Probe failure. This will set the <i>Alarms.H2_Remte</i> field TRUE.
MxCnRcvT	The Probe cleaning sequence is not permitted, possibly caused by a failure to achieve 95% of the Input value before the defined maximum recovery time after cleaning has expired. This will set the <i>Alarms.ClnRcvWn</i> field TRUE. To resolve, launch the cleaning process and ensure the Probe clean sequence completes successfully. If alarms continues, replace the probe.
MxImRcvT	The Probe impedance measurement recovery time has been exceeded, possibly caused by a Probe failure. This will set the <i>Alarms.ImpRcWrn</i> field TRUE. To resolve, launch the probe clean sequence and ensure it completes successfully. If alarms continues, replace the probe.

D13.6.1 Fault Diagnostics (Cont.)

Block Field	Description/To Resolve
PrbImpHi	<p>The maximum probe impedance threshold value has been exceeded, possibly caused by a Probe failure. This will set the <i>Alarms.PrbImpHi</i> field TRUE.</p> <p>To resolve, ensure the Probe impedance measurement sequence completes successfully or reset the impedance measurement message field (<i>ImpMsgRt</i> TRUE).</p>
ImpRcvWn	<p>The Probe impedance measuring sequence could not be performed. This will set the <i>Alarms.ImpRcvWn</i> field TRUE.</p> <p>To resolve, launch the impedance measuring process and ensure the Probe impedance measuring completes successfully.</p>

Table D13.1 Fault Indication

D13.7 SPECIFICATIONS

D13.7.1 ZI Module

Input Types: Analogue voltage, Channel 1 - mV (TC), and Channel 2 - 2V (Zirconia probe)

Thermocouple Input Specification (Ch1 ONLY)

Input Range:	-77mV to +100mV.
Calibration Accuracy:	± 0.1% of 'AI' parameter reading, ± 10µV.
Noise:	<4µV p-p with 1.6s Filter, better with longer time constants.
Resolution:	<1µV with 1.6s Filter.
Sensor Break Detect:	250nA break high.
Input Impedance:	10MΩ

Cold Junction Sensor Specification (Ch1 ONLY)

Temperature Range:	-10°C to +70°C
CJ Rejection:	< 30:1
CJ Accuracy:	± 1.3°C, ±0.5°C typ. ('Automatic' cold junction compensation).

Zirconia Input Specification (Ch2 ONLY)

Input Range:	-10mV to +1800mV.
Calibration Accuracy:	± 0.2% of 'AI' parameter reading.
Noise:	<1.5mV p-p with 1.6s Filter, better with longer time constants.
Resolution:	<50µV with 1.6s Filter.
Sensor Impedance Measurement:	0 Ω to 100 kΩ, ±2%.
Input Impedance:	>500 MΩ
Input Leakage Current:	-4.0 to +4.0nA, ±1nA typ.

General Specifications

Module power consumption:	1.8W max
Common mode rejection:	>80db, 48 - 62Hz
Series mode rejection:	>60db, 48 - 62Hz
Isolation channel - channel:	Functional (basic insulation), 264Vac max
Isolation to system:	Reinforced (double insulation), 264Vac max

Index

Symbols

- .cpf file 4-2
 - .dbf file 1-5, 2-20, 5-4, 5-8
 - .gwf file 5-4, 5-8
 - .ofl file 5-4
 - .sdb file 5-4
 - .sfc file 1-5
 - .sto file 5-4
 - .stx file 5-4
 - .udz file 8-1
 - .ujg file 5-4
 - .unh file C-15
 - .uxp file 5-4
 - .uys file 5-4
 - _auto.dbf file 1-4
 - _auto.run file 1-4, 5-2
 - 3-Term Control 6-3, 6-4
 - 3_Term block 6-1
- A**
- ACTION block 1-4, 7-6
 - Address
 - Internet Protocol, IP 2-10
 - LN Node Number 2-11, 2-12, 2-13
 - Alarms page C-8
 - All Subnet Enable C-15
 - AN_CONN block 7-8
 - Application POST 10-9
 - Automatic Configuration 1-4
 - Automatic I/O Build 5-2, 5-7
 - _auto.run 5-2
 - Preparing 5-2, 5-3
 - Automatic Tuning 1-1, 6-13, 7-6
 - Autosynchronisation 4-7
- B**
- Base Unit 2-7
 - Layout 2-4
 - Mounting 2-7
 - Basic I/O System (BIOS) 10-1
 - Battery 2-6, 2-21, 10-2, 11-1
 - Replacement 11-3
 - Block
 - See also Function Block*
 - Boot ROM POST 10-9
- C**
- Cables 2-18
 - Category 5 2-16
 - Cross-over 2-17
 - Straight-through 2-17
 - Cached block 7-1, 7-4, 7-7
 - Central Processing Unit, CPU 3-4, 7-1, 7-6, B-5
 - loading 7-6
 - Time 7-1
 - Changeover 1-3, 3-5, 4-7
 - Automatic 1-3
 - contacts D11-1
 - Changeover and Communications LEDs, & Switches 3-5
 - Desync switch 3-6
 - Ethernet (Activity) LED 3-6
 - Ethernet (Speed) LED 3-6
 - Ethernet Communications Port 3-6
 - Primary LED 3-5
 - Standby LED 3-5
 - Sync switch 3-5, 3-6
 - Coherent Data 7-4, 7-7, C-10
 - Cold Start 2-12
 - Parameter file 4-2
 - primary 2-12
 - secondary 2-13
 - Communications 2-17
 - Cabling 2-18
 - ELIN 2-17
 - ELIN Connectors 2-17
 - Ethernet 2-17
 - Ethernet HUBS/Switch 2-18
 - Modbus-TCP 2-17
 - Profibus 2-19
 - Profibus Connectors 2-19
 - Serial 2-17, 2-19
 - Serial Connectors 2-19
 - Compact Flash Card replacement 11-2
 - Configuration 1-1, 5-1
 - Automatic 1-4, 1-5, 1-6
 - Ladder Diagrams 1-5, 1-6
 - LNtools 1-4
 - Configuration Tools 2-20, 5-1, C-1
 - Automatic I/O Build 5-2, 5-3, 5-4, 5-7
 - LNtools 2-20, 5-4, 5-5, 5-6, C-1
 - Terminal Configurator 2-20, 5-7, C-1, C-2
 - Connections and Wiring 2-16, D2-2, D3-2, D4-2, D5-2, D6-2, D7-2, D8-2, D9-2, D10-2, D11-2, D12-2, D13-2
 - DC supply wiring 2-21
 - Duplex connection 2-16
 - Safety earth 2-21
 - Simplex connection 2-16
 - Watchdog relay 2-22
 - Contact bounce suppression D6-1, D7-1, D8-1
 - Control 6-3
 - 3-Term 6-3, 6-4
 - Motorised Valve 6-3, 6-4
 - On/Off 6-3
 - PID 6-3, 6-4
 - Valve Position 6-3
 - Control Strategy
 - See also Strategy*
 - COSHH 1-1
 - Battery A-8
 - Battery Specification A-8
 - Simplex T2550S module A-8
 - Current D2-1, D4-1, D5-1, D12-1

D

D	
Data	7-7
Coherent	7-7, C-10
Non-coherent	7-8
Data Archiving	9-2
Data Management	1-4
Database	5-1, 5-4, 5-6, 10-1, 10-6, 10-10
Configuration	C-4
Start-up	7-6
Stop	10-6
Decoupled Instruments	10-6
DeleteReq	C-11
Desync switch	3-6
Diagnostic	10-1
Diagnostic blocks	1-5, 10-1, 10-10
Diagnostic Tests	10-1, B-1
POSTs	10-9
DIN Rail	2-7
Mounting	2-7
Direct Panel	2-7
Mounting	2-7
Duplex	1-2, 2-4
Control System	2-16
LED	4-7
LIN Terminal Unit	1-3, 2-5
Profibus Terminal Unit	1-3, 2-5
Start-up sequence	4-6, 10-9
Start-up sequence decisions	4-7
Starting a duplex system	4-6
Dynamic Tuning	7-6

E

Electrical isolation ...	D2-4, D3-3, D4-3, D5-3, D6-3, D7-4, D8-3, D9-3, D10-3, D11-3, D12-5, D13-4
ELIN	
<i>See also</i> Ethernet	
ELIN Setup page	C-15
Error	B-1
Event log	8-2
Message	B-4
Number	10-1, 10-9, B-1
Number Structure	B-4
Error Conditions	1-1, 10-1, 10-7
Diagnostic blocks	10-1
LEDs	10-1
POSTs	10-1
Ethernet	1-3
Communications	1-3, 2-17, 3-6
Hub/Switch	2-16
LIN network	1-1
Event Log	1-1, 1-4, 8-1
Execution times	7-3

F

Failure modes	10-4
Instrument	10-4
Inter-processor Communications Mechanism	10-5
Local Instrument Network	10-5

Power	10-4
Watchdog	10-4
Fault	D12-8, D13-6
Detection	D12-8, D13-6
Diagnostics	D12-8, D13-6
Features	1-3
Field writes	7-8
FILE	C-14
Firmware upgrade	11-2
Full Description page	C-6
Function Block	1-1, 2-20, 5-8, C-1
Categories	C-4
Configuration	C-4
Diagnostic	1-5
Header	C-4
Structure	1-4
Support	1-5, 1-6
Tactician header block	2-23, 8-2
Task Updates	7-8

G

Gain Scheduling	6-10, 6-24
GWProfS_CON block	5-9

H

Handling precautions	2-3
HART Compatibility	D3-4
Health Monitoring	1-4
High and low output limit	D9-1
High Impedance (Zirconia)	D2-1, D13-1
Hot/Cold Start Switch	2-14
Hysteresis	6-25

I

I/O Module	D-1
Compatibility	D-1
Isolator Links & Fuses	D-1
Installation	1-1, 2-1, 2-4
Category II	A-1
Safety requirements	2-1
Instrument	1-2, 10-4
Failure modes	10-4
System Software	11-1
Instrument Properties dialog	C-15
Inter-processor Communications Mechanism, ICM	1-3
Communications	1-3, 10-9
Inter-server connections	7-7
IP Address	2-10, C-15
BootP	2-10
DHCP	2-10, 4-7
Editing the 'network.unh' file	2-11
Instrument Properties dialog	C-15
Link-Local	2-10
Manual	2-10
network.unh	C-15
Recovery from Unknown Configuration	2-11
Setting	2-10
Isolator links and Fuses	2-8

- L**
- L**
- Label symbols 2-3, D11-2
 - Layout 2-4
 - LED 3-1, 10-2
 - Battery 4-5
 - Changeover 3-5
 - Communications 3-5, 4-5
 - Duplex 4-7
 - Error Conditions 10-1
 - Error Displays 10-2
 - Front Panel 1-4
 - Indication at start up (BIOS) 4-5
 - IP Resolution 4-7
 - Primary 4-5
 - Standby 4-7
 - Status 4-5
 - LIN 1-3
 - Communications 1-3
 - Instrument 1-3
 - Local Instrument Network 1-3
 - Node Number 2-10
 - Systems B-4
 - LIN Blocks
 - See also Function Block*
 - LIN Database
 - See also Database*
 - Links 2-15, D12-2, D12-11
 - LINtools 1-1, 5-4, 6-1, C-1
 - Action 5-4
 - Action, .sto file 5-4
 - Action, .stx file 5-4
 - Configuration 1-4
 - Database, .dbf file 1-5, 5-4, 5-8
 - Ladder configuration 1-5, 1-6
 - Modbus Gateway, .gwf file 5-4, 5-8, 5-9
 - Modbus Gateway Configuration 5-4
 - Modbus Gateway File 5-8, 5-9
 - Object Properties pane C-5
 - On-line Reconfiguration 5-4
 - Sequence 1-5
 - Sequential Function Chart, .sdb file 1-1, 1-5, 5-4
 - Structured Text (ST) 1-4, 4-2
 - Loop block 6-11, 6-14, 6-20, 6-24
 - Loop Break 6-9
- M**
- Maintenance schedule 11-1
 - Manual Tuning 6-17
 - Manual tuning 7-6
 - Mechanical Layout & Installation 2-4
 - Minimum pulse time D11-1
 - Modbus 1-1, 2-23, 5-8
 - Communications 2-23
 - Master 2-23, 5-8
 - Slave 2-23, 5-8
 - Modbus Configuration Editor, Mdbtools 5-8
 - Modbus Configuration File, .ujg file 5-4, 5-9
 - Modbus Gateway File, .gwf file 5-8, 5-9
 - Modbus-TCP 2-17
 - Connector Pinout 2-17
 - Module 1-2, 2-3
 - Fitting 2-9
 - I/O1-2, 2-3, D2-1, D3-1, D4-1, D5-1, D6-1, D7-1, D8-1, D9-1, D10-1, D11-1, D12-1, D13-1
 - Removing 2-9
 - T2550R 1-2, 2-4
 - T2550S 1-2, 2-4
 - Motorised Valve Control 6-3
 - Mounting Base Unit 2-7
 - DIN Rail 2-7
 - Direct Panel 2-7
 - Mounting Power Supply Module D1-5
 - DIN Rail D1-5
- N**
- Network Ports 3-1
 - Network setup page C-12
 - Network.unh file 2-10
 - Non-coherent data transmission 7-8
- O**
- On-line Reconfiguration 1-1, 5-4, 5-7
 - DeleteReq C-11
 - Tentative C-10
 - On-Time 6-3, 6-12, 6-23
 - On/Off control 6-1, 6-3
 - Channel 2 Deadband, OP.CH2DeadB 6-26
 - On/Off mode D11-1
 - Options Switch 10-9
 - Options.AllSubnt C-15
 - Other Information Sources 1-1
 - Overview page C-8
- P**
- Peer-to-Peer 1-3
 - Communications 1-3
 - PID control 6-1, 6-3, 6-26
 - Channel 2 Deadband, OP.CH2DeadB 6-26
 - Derivative Time, Td 6-7, 6-11
 - Gain Scheduling 6-10
 - High and Low Cutback, CBHand CBL 6-8, 6-11, 6-18
 - Integral Time, Ti 6-6, 6-11
 - Loop Break Time, LBT 6-9, 6-24
 - Manual Reset, MR 6-8
 - PID block 6-1
 - Proportional Band, PB 6-5, 6-11
 - Relative Cool Gain, R2G 6-7, 6-11, 6-17, 6-23
 - Plant sensors D2-1, D4-1, D12-1, D13-1
 - Platinum Resistance Thermometers D2-1
 - Pollution 2-2
 - Conductive Pollution 2-2
 - Pollution degree 2 A-1
 - Port Number 2-10
 - POSTs 1-1
 - Power Consumption D-1
 - Power cycle C-15
 - Power On Self Tests (POSTs) 10-9, B-1
 - Application 10-9
 - Boot ROM 10-9
 - Diagnostic tests 10-9

P (Cont.)

Power Supply	1-3, 2-4, 2-21
DC Wiring	2-21
Fuses	2-21
Redundant Connection	1-3
Safety earth connection	2-21
Power Supply Module	D1-1
DIN Rail Mounting	D1-5
Input Specification	D1-4
Output Specification	D1-4
Product code	D1-1
Serial number	D1-1
Status Indication	D1-3
Wiring and Connections	D1-2
Power-up Failure	10-7
Power-up routine	10-7
Preventive Maintenance Schedule	11-1
Primary/Secondary	4-1
Criteria	4-6
Product safety	2-2
Profibus	1-1, 1-3, 2-17, 2-23, 5-9
Demand Data	5-9
Input data	5-9
Master	5-9
Output data	5-9
Slave	1-3, 5-9

R

Real-Time Clock	1-3, 2-4, 2-21
RED_CTRL block	4-8, 10-6
PrHWstat.ICM_Ok	10-5
PrSWstat.Decoupld	10-6
SeHWstat.ICM_Ok	10-5
SeSWstat.Decoupld	10-6
Redundancy	1-2
Automatic Changeover	1-3
Decisions	4-7
Power Supply	1-3
T2550R modules	1-4, 1-5, 1-6
Redundancy Modes	4-1
Duplex mode	4-1
Simplex mode	4-1
Relay Output	
Fused	D11-3
Unfused	D11-3
Repeat Rate	7-3
Repeat times	7-3
Replacement	1-3
Battery	11-3
Compact Flash Card	11-2
Live	1-3
Procedures	11-1, 11-2

S

Safety & EMC Information	2-1
Safety Earth Connection	2-21
Save	
Database	5-2
Sensor Break Action	D2-1, D13-1
Sequences	1-4, 1-5, 3-6
Loading	1-5, 3-6
Unloading	1-5, 3-6

Sequential Function Chart	1-1, 1-5, 3-6, 7-6
Serial Communications	2-17
Connector Pinout	2-19
Serial line set-up	5-8
Server	7-3
User task	7-4
Service	1-1, 3-1, 11-1
Setpoint Program	5-4
Setpoint Configuration, .uys file	5-4
Setpoint Tracking	6-20
Manual	6-20
Simplex	1-3, 2-4
Battery	11-1
Control System	2-16
Start-up Sequence	4-5
Starting a Simplex system	4-5
T2550S module	11-1
Two Processor Non-redundant	4-8
Snubber Circuits	D11-1
Removal	D11-6
Software Function Blocks	C-1
Specification	1-1, A-1
2500P	D1-4
AI2 DC Module	D2-8
AI2 mA Module	D2-10
AI2 TC Module	D2-7, D13-8
AI3 Module	D3-6
AI4 mV Module	D4-7
AI4 TC Module	D4-6
AO2 Module	D5-5
DI4 Module	D6-6, D8-6
DI6 Module	D7-7
DO4 Module	D9-6, D10-6
FI2 Module	D12-9, D13-8
RLY4 Module	D11-5
T2550R	A-2
SRAM	1-3, 2-4
Standby LED	4-7
Start-up	1-1, 4-1, 4-3
Cold start	4-2
Duplex mode	4-6
Hot start	4-1
Mode	4-1, 4-5
Simplex mode	4-5
Status	
Indication ..D2-6, D3-5, D4-5, D5-4, D6-5, D7-6, D8-5, D9-5, D10-5, D11-4, D12-7, D13-5	
LEDs	3-3
Strategy	2-20, 4-1, 5-4, 5-6, 5-7, 6-1, 10-1
Structured Text	1-4
User Algorithm	1-4
Switch(s)	2-12, 3-1, 3-3, 3-5
Desync	3-6
Hot/Cold Start	2-14
Sync	3-5
Watchdog Retry	1-4, 2-14
Symbols used in labelling	2-3
Sync switch	3-5
Synchronisation	4-7
Time to achieve	4-8

T	
T2550	1-1
Base Unit (T2550B)	1-2
Duplex Module (T2550R)	1-2, 2-4
Duplex Module Layout	2-6
I/O Modules (2500M)	1-2
Live Module Replacement	1-3
Simplex Module (T2550S)	1-2, 2-4
System Software	11-1
Terminal Units (2500T)	1-2
Tactician blocks	2-23
TACTIONE block	7-6
Task	7-1
Functions	7-1
Organisation & Tuning	7-1
Priorities	7-1
Scheduling	7-1
Task Organisation and Tuning	1-1
TCP	5-8
Telnet	C-2
Terminal Configurator	C-2, C-4, C-16
Tentative	C-10
Terminal Configurator	1-1, 5-7, C-1
Configurable items	C-1
Initial menu	C-3
Initial Menu Access	C-2
LIN Database configuration	C-4
Modbus Configuration	C-16
Quitting	C-3
Running	C-2
Telnet	C-4, C-16
Terminal Unit	1-2
2500T	1-2
Duplex	2-6, 10-2
Fitting	2-8
Layout	2-5
LIN	2-6, 10-2
Links	2-12
Profibus	2-6, 10-2
Removing	2-8
Simplex	2-6, 10-2
Switches	2-12, 4-1
Thermocouples	D2-1, D4-1, D12-1, D13-1
Time Proportioning mode	D11-1
Time Proportioning output mode	D9-1, D10-1
Tracking	6-19, 6-20
Manual	6-20
Setpoint	6-20
Total Output	6-22
Tune_Set block	6-2, 6-21
Gain Scheduling	6-10
Tuning	6-11, 7-6
Automatic	6-13
Control Loop	6-11
Loop	6-11
Manual	6-17
Typical applications	1-2
U	
Unpacking	2-3
User Calibration	D2-1, D3-1, D4-1, D13-1
User Interface	3-3
(Battery) LED	3-3
(Communications) LED	3-3
(Status) LED	3-3
Duplex LED	3-4
IP (IP Resolution) LED	3-4
Status LEDs & Switches	3-3
Watchdog Switch	3-4
X (Fault) LED	3-3
User Screen PageSet	5-4, 5-6
Operator InterFace Language, .off file	5-4
User Screen Configuration, .uxp file	5-4
User Task	7-3
Execution Times	7-3
Server Operation	7-4, 7-5
Terminology	7-3
Tuning	7-1, 7-6
USERTASK block	7-6
UTILITIES OPTIONS menu	C-13
APPLY/UNDO command	C-14
FILE command	C-14
LOAD command	C-14
SAVE command	C-13
START command	C-13
STOP command	C-13
TRY/UNTRY Changes command	C-14
V	
Valve Position	6-3, D11-1
Bounded VP (VPB) control	6-1, 6-4
Boundless VP (VPU) control	6-1, 6-4
Voltage	D2-1, D4-1, D5-1, D12-1
Input curves	D7-3
W	
Watchdog Relay	1-4, 4-5, A-4
Alarm state	4-5
Watchdog Retry Switch	2-14
Wiring	2-16

Intentionally left blank

Inter-Company sales and service locations

AUSTRALIA Sydney

Eurotherm Pty. Ltd.
Telephone (+61 2) 9838 0099
Fax (+61 2) 9838 9288
E-mail info.au@eurotherm.com

AUSTRIA Vienna

Eurotherm GmbH
Telephone (+43 1) 7987601
Fax (+43 1) 7987605
E-mail info.at@eurotherm.com

BELGIUM & LUXEMBOURG Moha

Eurotherm S.A./N.V.
Telephone (+32) 85 274080
Fax (+32) 85 274081
E-mail info.be@eurotherm.com

BRAZIL Campinas-SP

Eurotherm Ltda.
Telephone (+5519) 3707 5333
Fax (+5519) 3707 5345
E-mail info.br@eurotherm.com

DENMARK Copenhagen

Eurotherm Danmark AS
Telephone (+45 70) 234670
Fax (+45 70) 234660
E-mail info.dk@eurotherm.com

FINLAND Abo

Eurotherm Finland
Telephone (+358) 22506030
Fax (+358) 22503201
E-mail info.fi@eurotherm.com

FRANCE Lyon

Eurotherm Automation SA
Telephone (+33 478) 664500
Fax (+33 478) 352490
E-mail info.fr@eurotherm.com

GERMANY Limburg

Eurotherm Deutschland GmbH
Telephone (+49 6431) 2980
Fax (+49 6431) 298119
E-mail info.de@eurotherm.com

HONG KONG & CHINA

Eurotherm Limited North Point
Telephone (+85 2) 28733826
Fax (+85 2) 28700148
E-mail info.hk@eurotherm.com

Guangzhou Office

Telephone (+86 20) 8755 5099
Fax (+86 20) 8755 5831
E-mail info.cn@eurotherm.com

Beijing Office

Telephone (+86 10) 6567 8506
Fax (+86 10) 6567 8509
E-mail info.cn@eurotherm.com

Shanghai Office

Telephone (+86 21) 6145 1188
Fax (+86 21) 6145 1187
E-mail info.cn@eurotherm.com

INDIA Chennai

Eurotherm India Limited
Telephone (+9144) 2496 1129
Fax (+9144) 2496 1831
E-mail info.in@eurotherm.com

IRELAND Dublin

Eurotherm Ireland Limited
Telephone (+353 1) 4691800
Fax (+353 1) 4691300
E-mail info.ie@eurotherm.com

ITALY Como

Eurotherm S.r.l.
Telephone (+39 031) 975111
Fax (+39 031) 977512
E-mail info.it@eurotherm.com

KOREA Seoul

Eurotherm Korea Limited
Telephone (+82 31) 2738507
Fax (+82 31) 2738508
E-mail info.kr@eurotherm.com

NETHERLANDS Alphen a/d Rijn

Eurotherm B.V.
Telephone (+31 172) 411752
Fax (+31 172) 417260
E-mail info.nl@eurotherm.com

NORWAY Oslo

Eurotherm A/S
Telephone (+47 67) 592170
Fax (+47 67) 118301
E-mail info.no@eurotherm.com

POLAND Katowice

Invensys Eurotherm Sp z o.o
Telephone (+48 32) 218 5100
Fax (+48 32) 217 7171
E-mail info.pl@eurotherm.com

SPAIN Madrid

Eurotherm España SA
Telephone (+34 91) 661 6001
Fax (+34 91) 661 9093
E-mail info.es@eurotherm.com

SWEDEN Malmo

Eurotherm AB
Telephone (+46 40) 384500
Fax (+46 40) 384545
E-mail info.se@eurotherm.com

SWITZERLAND Wollerau

Eurotherm Produkte (Schweiz) AG
Telephone (+41 44) 787 1040
Fax (+41 44) 787 1044
E-mail info.ch@eurotherm.com

UNITED KINGDOM Worthing

Eurotherm Limited
Telephone (+44 1903) 268500
Fax (+44 1903) 265982
E-mail info.uk@eurotherm.com
Web www.eurotherm.co.uk

U.S.A Leesburg VA

Eurotherm Inc.
Telephone (+1 703) 443 0000
Fax (+1 703) 669 1300
E-mail info.us@eurotherm.com
Web www.eurotherm.com

ED54



invensys
EUROTHERM
EUROTHERM LIMITED

Faraday Close, Durrington, Worthing, West Sussex, BN13 3PL
Telephone: +44 (0)1903 268500 Facsimile: +44 (0)1903 265982
e-mail: info.uk@eurotherm.com
Website: <http://www.eurotherm.co.uk>