

K1E

CUSTOMISABLE TEMPERATURE CONTROLLER

CE

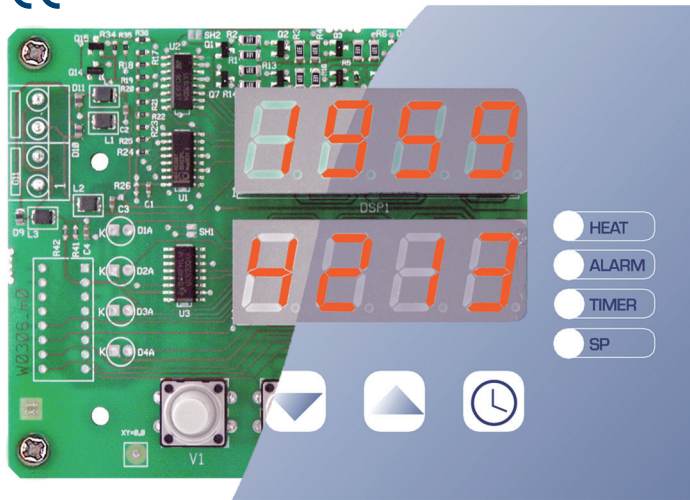

K1E

- AUTORANGING DUAL LINE, 4 DIGIT DISPLAY
- SMART AUTOMATIC TUNING CONTROL ALGORITHM
- PROCESS TIMER WITH CONFIGURABLE OPERATING MODES
- TWO POINT AUTOMATIC SYSTEM CALIBRATION FUNCTION
- UNIVERSAL TC AND RTD INPUT
- 1 SSR OUTPUT (CONTROL)
- 2 RELAY OUTPUTS (ALARM/ CONTROL)
- 3 CONFIGURABLE LOGIC INPUT CHANNELS
- INTEGRAL ALARM - TIMER BUZZER OPTION
- "SOFT START" (OUTPUT POWER LIMITER FUNCTION)
- RS232 MODBUS COMMUNICATION OPTION
- UNIVERSAL POWER SUPPLY (85 - 265V AC)
- BUILT IN SERIAL INTERFACE FOR FAST CONFIGURATION BY PC BASED SOFTWARE

K1E

OVERVIEW - CONCEPT

The K1E offers a truly flexible control solution for compact heating and cooling applications such as laboratory equipment, food service, packaging and drying machinery. The dual PCB assembly allows the K1E to be easily fitted inside compact equipment unsuitable for conventional panel mounting control packages.

Functionality includes: application optimised "SMART" auto tuning PID algorithm for heat and heat/cool control, process timer, process protection alarms and an independent over temperature protection circuit.

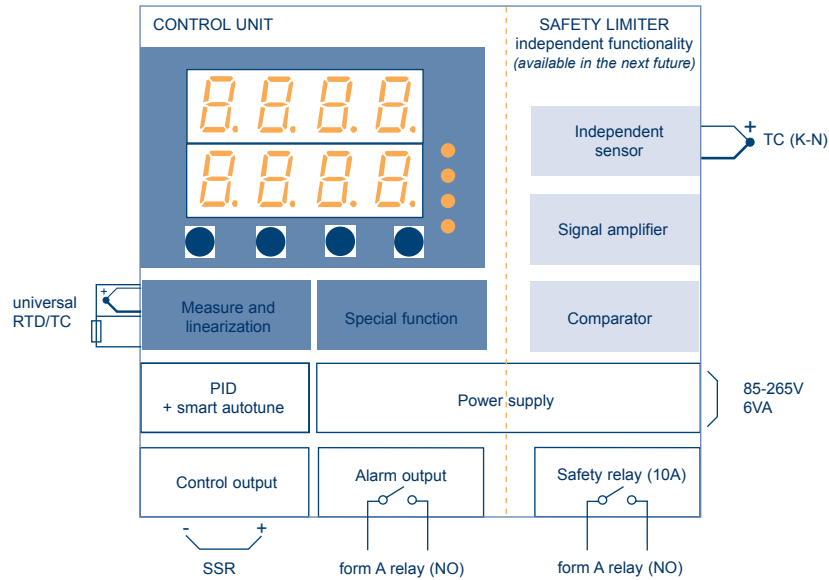

SIMPLE OPERATOR INTERFACE

Simplicity is the key to the K1E user interface. Functions are easily accessed without complex navigation procedures. The auto-ranging display provides a compact easy to read display and precision where it's needed.

Display range -199 to 1999°C/ °F. Display resolution is 0.1 between -199.9 and 999.9°C/ °F.

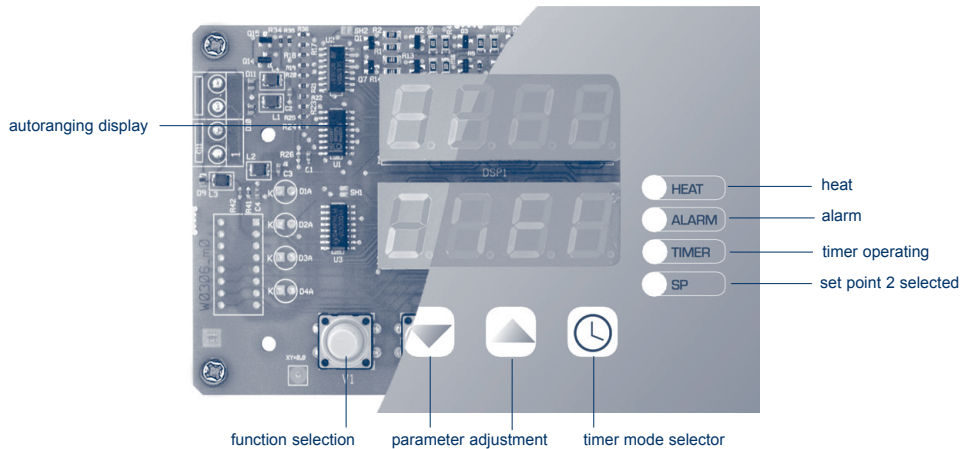

INDEPENDENT OVER TEMPERATURE SAFETY LIMITER

**available in the near future

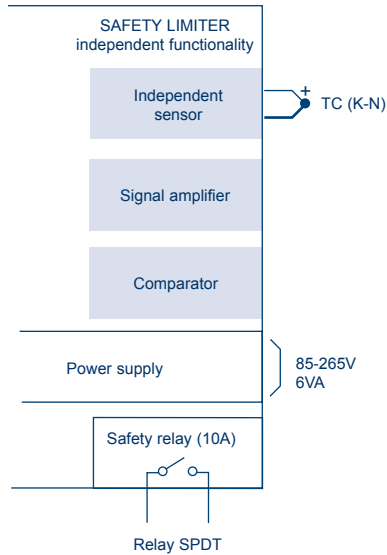

In addition to the K1E standard control and alarm functionality an independent over temperature protection option is available. This uses a dedicated thermal sensor and protection circuitry to provide 2 levels of safely protection from over temperature faults.

1. Absolute over temperature shut off to protect the equipment. This is not user adjustable.
2. User adjustable high temperature limit with selectable set point tracking allowing product protection within the process.

TIMER

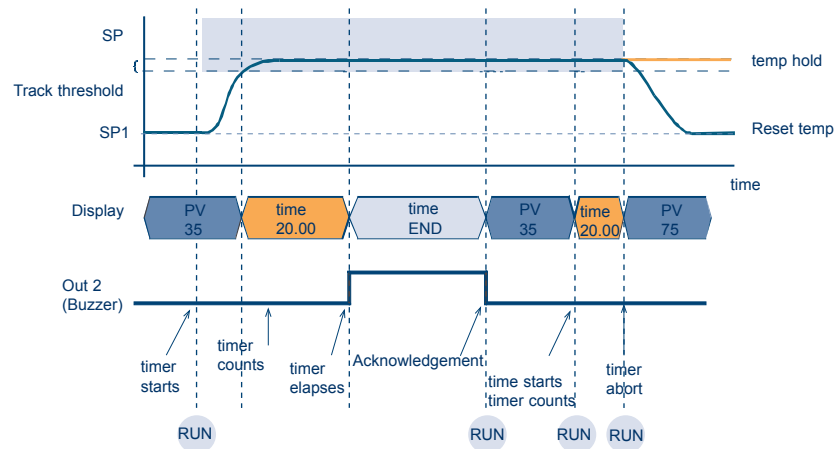

An integral timer function is available in the K1E which provides timed control of a heating or cooling cycle.

An audible alarm option is available to indicate the end of the timer cycle. During a timed heating or cooling cycle the display indicates time remaining. Configurable timer options include: guaranteed soak, ramp rate control and temperature hold or reset at end of timer cycle.

AUTOMATIC 2 - POINT SYSTEM CALIBRATION FACILITY

The K1E calibration system automatically compensates for differences between the indicated and true system temperature that is caused by thermal gradients between heating and cooling sources and cabinet insulation.

The built in calibration procedure calculates true temperature values over the operating range of the equipment from 2 reference calibration points. This feature follows an easy to use automated step-by-step sequence that may be easily operated, with minimum supervision by production personal.

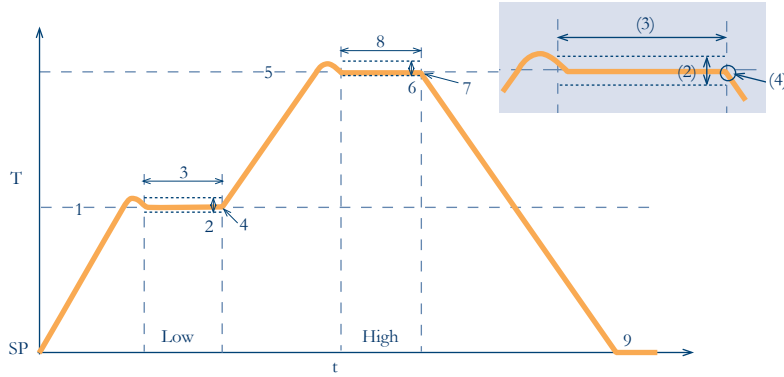

AUTOMATIC 2 POINT SYSTEM CALIBRATION PARAMETERS

1. Calibration setpoint, Low
2. Low calibration point stabilisation band
3. Low calibration point stabilisation time
4. Operator adjustment of displayed value
5. Calibration setpoint, High
6. High calibration point stabilisation band
7. High calibration point stabilisation time
8. Operator adjustment of displayed value
9. End of calibration sequence, return to working setpoint

CONFIGURATION PORT

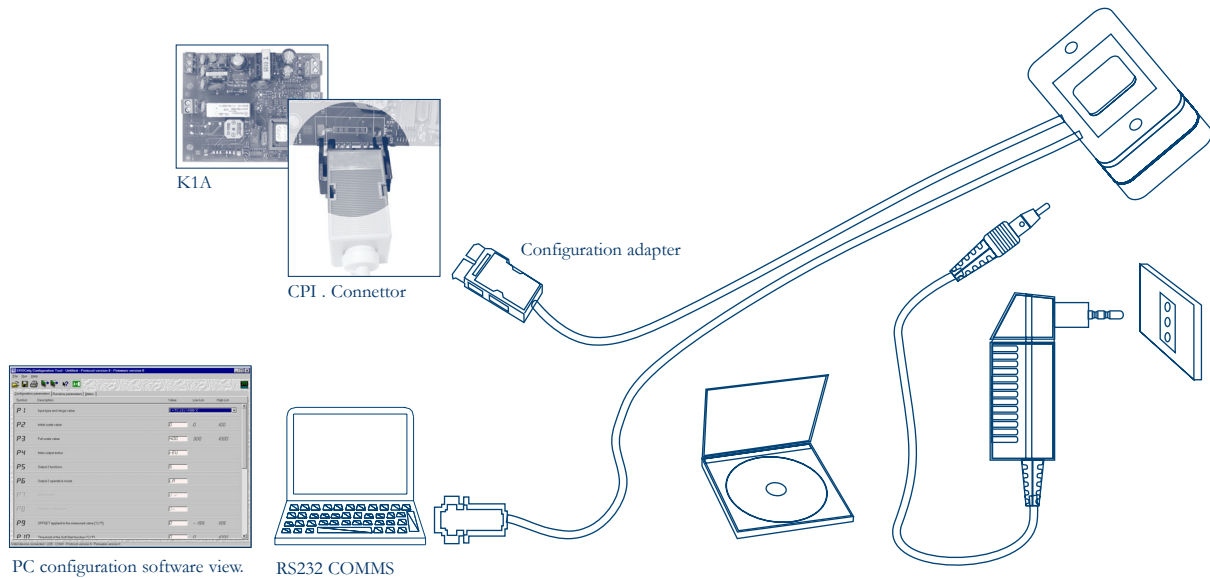

Direct communication between the controller and a PC is possible using the CPI allowing easy configuration between the instrument configuration port and the PC RS232 port (COM1/COM2).

PC based ERO Electronic Config software speeds and simplifies configuration by providing guided menus for complete instrument set-up and has the facility to save and copy complete instrument configurations.

PRODUCT SPECIFICATION

Terminals:	13 screw terminals (screw M3, for cable from 0.25 to 2.5mm or from AWG 22 to AWG 14)
Dimensions:	100 x 150mm, depth 88mm.
Weight:	130g max.
Supply:	85V to 265V AC; 50/60Hz; 6VA (max) note: the K1E with RS232 supply is derated to 200 to 240 V (-30% to +10%)
Isolation voltage:	2300V RMS according to EN 61010-1.
Sampling time:	500mSec.
Common mode rejection ratio:	>120dB at 50/60Hz.
Normal mode rejection ratio:	>60dB at 50/60Hz.
EMC/Safety:	conforms to council directives 89/336/EEC (reference harmonized standard EN-50081-2 and EN-50082-2), 73/23/EEC and 93/68/EEC (reference harmonized standard EN 61010-1).
Installation category:	II
Accuracy:	± 0,3% f.s.v. ± 1 digit @ 25 °C ambient and nominal power supply.
Temperature drift:	< 200 ppm/°C for TC type L, J, K, N (CJ excluded) < 400 ppm/°C for RTD and TC type T. < 500 ppm/°C for TC type R, S (CJ excluded).
Operative temperature:	from 0 to 50°C.
Storage temperature:	from -20 to +85°C
Operative Humidity:	from 20 % to 85% RH, non condensing.

CONTROL ACTION

Control output type:	time proportioning.
Control action type:	PID + PI + SMART + ON/OFF (heat/cool/heat+cool).
Proportional band:	from 1.0 % (for one control output) or 1.5 % (for two control outputs) to 100 % of the input span.
Main output cycle time:	from 1second to 200 seconds.
Secondary output cycle time:	from 1second to 200 seconds.

MEASURING INPUT

Termocouple

<i>Sensor break:</i>	open TC detection (wire or sensor) with overrange indication.
<i>Cold junction:</i>	automatic compensation from 0 to 50°C ambient temperature.
<i>Cold junction compensation error:</i>	0.1 °C/°C.
<i>Calibration:</i>	according to IEC 584-1 and DIN 43710 - 1977 (TC L).

Standard range table

TC type	°C	°F
L	-100/ 900	-148/1652
J	-100/1000	-148/1832
K	-100/1370	-148/2498
N	-100/1400	-148/2552
T	-100/400	-148/752
R	-20/1760	-4/3200
S	-20/1760	-4/3200

RTD

<i>Type:</i>	Pt 100 - 3 wire connection.
<i>Measure current:</i>	130µA.
<i>Line resistance:</i>	automatic compensation up to 20Ω /wire with: - error <+0.1% of the span - no measurable error for all other range
<i>Sensor break:</i>	open circuit detection (wire or sensor). Short circuit indication when the sensor resistance is lower than 15Ω.

Standard range table

RTD type	°C	°F
PT 100	-200/800	-328/1472

OUTPUTS

Output 1

Function: control output heating
Type: SSR not isolated output.
- Logic level 1: 8V DC @ 12 mA max.
- Logic level 0: < 0.5V DC

Output 2

Function: control output or alarm/cooling
Type: relay (form A)
Contact rating: 10A @ 250V A.C. on resistive load.

Output 3 - Buzzer

Function: alarm or timer status
Type: piezoelectric buzzer
Frequency: 3 kHz
Sound pressure: 75dB (at 30 cm)

Output 3 - Relay

the relay output is in alternative to the buzzer
Function: alarm or timer status
Type: relay (form A)
Contact rating: 3A @ 250V AC on resistive load.

LOGIC INPUTS

Type: up to 3 logic input
dry contact
the contact should be able to switch a current of 5mA at 5V
sampling/ debounce period 300 mSec
Functions: configurable

ALARMS

Alarm action: direct or reverse programmable.
Alarm function: programmable as process, band or deviation alarm.
Alarm reset: programmable as automatic or manual reset.
Alarm masking: programmable as mask or standard alarm.
Hysteresis: in percentage of the input span 0,1% to 10,0%.

INDEPENDENT OVER TEMPERATURE LIMITER

**available in the next future

Input: TC - KN
Accuracy/Repeatability: 5°C (+/- 10%)
Output: 10A @ 250V AC on resistive load (form A) no contact rating
Fault protection:
- microprocessor fail
- power supply fault
- over temperature

DIMENSIONS AND ELECTRICAL CONNECTIONS

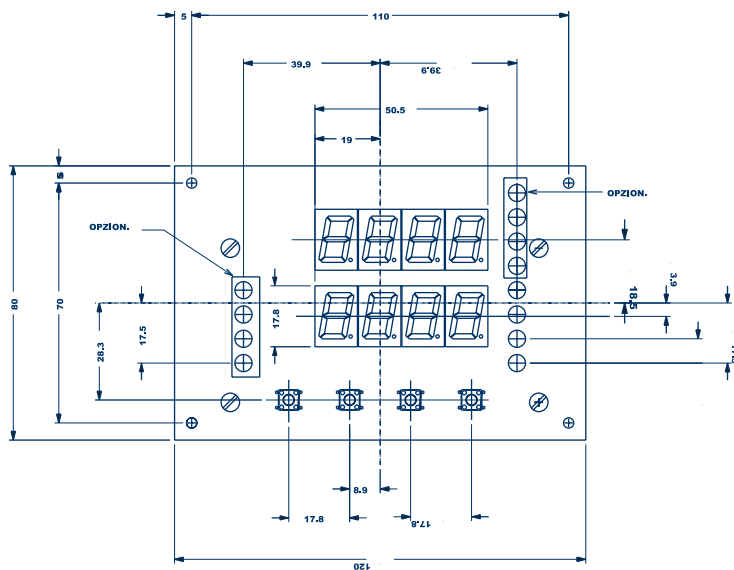

Display

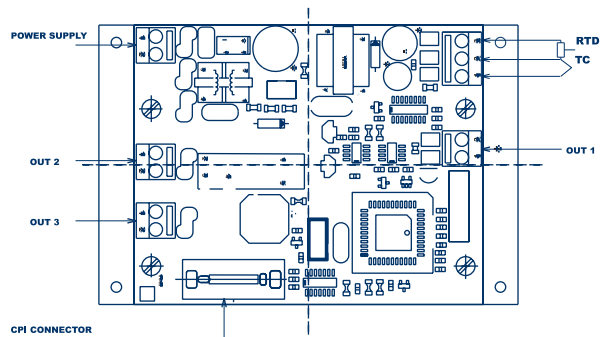

Main control/Power supply

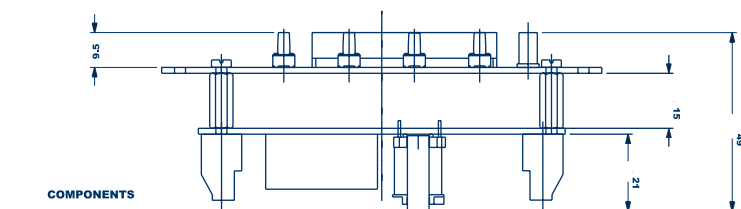

Assembly Side Profile

Note: all the dimensions in mm.

K1E

HOW TO ORDER

MODEL	INPUT	CONTROL ACTION	OUTPUT 3	OUTPUT 2	OUTPUT 3	OPTIONS	POWER SUPPLY	CUSTOMISATION	
K1E	4 digit dual line panel display	7 Thermistor (special)	3 PID	6 SSR	0 none	0 none	0 none	0000 Non default STD	
		8 TC	4 PID + SMART		6 SSR	3 Buzzer + timer	1 Two point cal +coms connection	5 24V AC or DC	XX00 Customisation
		9 TC + RTD input			1 Relay	4 Relay + timer	2 Safety limiter (special)		
		X TC + RTD input+3 digital input					3 two points offset + Safety limiter		
K1E			6						