

# Service instructions

## Process Supervisor

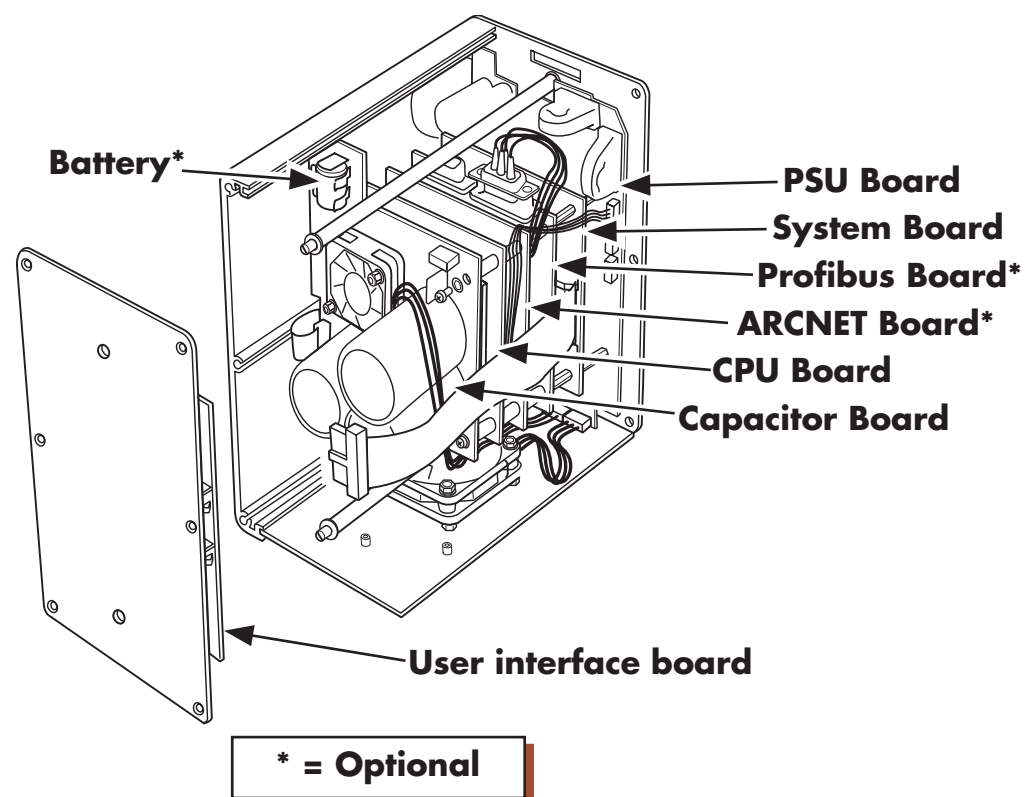

Figure 6 Hardware organisation



### CAUTION

These procedures involve the handling of components which are sensitive to static electrical discharge. All relevant personnel must be aware of static handling procedures.

## INTRODUCTION

These instructions show how to replace the service consumables as provided in the kit LA029186. Also included are battery fitting and flash card replacement instructions.

*Note:* These instructions apply to Process Supervisor processor units with a status level of G6 or higher. Units prior to this require a different kit of parts, available under part number LA028325

## Preventive Maintenance Schedule

The following periods are recommended to guarantee maximum availability of the processor unit, for use in what the manufacturer considers to be a normal environment. Should the environment be particularly dirty, or particularly clean, then the relevant parts of the schedule may be adjusted accordingly. For example, the fan filter may need replacing more frequently than every two years, if the unit is located in a dusty area.

The following are recommended:

1. A visual inspection of the chassis-mounted fan inlet (on the bottom plate of the unit) should be made every 6 months. The filter should be replaced if any clogging is evident. Packs containing five spare filters are available under part number LA029122.
2. Every two to four years, the service consumables listed below should be replaced. The recommended replacement period is a function of the average ambient temperature in which the unit operates. At an ambient of 50 degrees Celsius, the recommended replacement period is two years. For an ambient of 20 degrees Celsius the recommended period is four years. The service consumables are available from the manufacturer as a kit which has the part number LA029186. Service consumables are:
  - a) Chassis fan and pack of five filters.
  - b) Fan/capacitor board.

Whenever the unit is 'opened', it is recommended that a visual inspection of be made, and any deposits of dirt or dust removed using a low-pressure compressed 'air duster' such as are available from most electronics distributors.

  
 invensys  
**EUROTHERM**  
 EUROTHERM LIMITED  
 Faraday Close, Durrington, Worthing, West Sussex, BN13 3PL  
 Telephone: 01903 695888. Facsimile: 01903 695666  
 e-mail: info@eurotherm.co.uk  
 Website: http://www.eurotherm.co.uk

## REMOVAL OF MODULES

- 1 Unscrew both retaining screws (anticlockwise) to jack the unit out of its connector.
- 2 Lift the unit off its retaining catch.

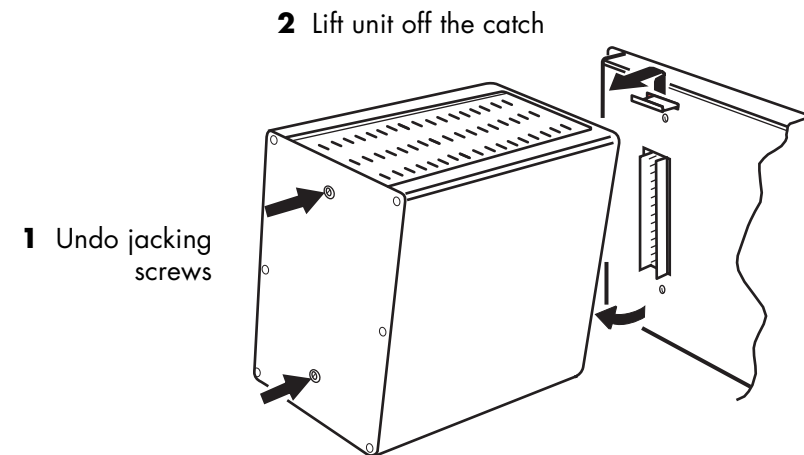

Figure 1 Module removal

## FITTING OF MODULES

- 1 Lift the module onto its retaining catch, and gently push the module towards the backplane to mate the connector.

**Caution**

**Do not force the unit onto its connector or damage will occur**

- 2 Re-engage and tighten both retaining screws a few turns each at a time, to a maximum torque of 2.5 Nm.

## FLASH CARD REPLACEMENT

Figure 5 shows the replacement of the 'Flash card' fitted to current units. This procedure allows data bases, user configurations etc. to be transferred from one processor module to another, allowing the 'Mean Time to Replace' to be reduced to a minimum.

1. Remove the relevant processor unit from the backplane (see page 2).
2. At the rear of the instrument, lift the front edge of the card, and pull it out of its connector.
3. Fit the replacement card.
- 4/ re-fit the processor unit to the back plane (see page 2).

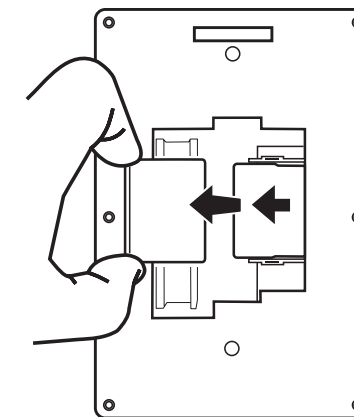

Figure 5 Flash card removal

## FIRMWARE UPGRADE

The manufacturer can supply replacement memory/flash cards pre-programmed with the latest firmware version. This allows the user to upgrade the unit just by replacing the card. In such cases, the user is responsible for reloading configuration files in the unit.

Alternatively, the manufacturer's agents can upgrade the firmware version with the card *in situ* thus retaining the user configuration.

## CAPACITOR BOARD/FAN REPLACEMENT (Cont.,)

8. Fit the fan to the new capacitor board using the fixings (K) previously removed ensuring correct orientation of both fan and fixings as described in the note and caution above.
9. Fit the capacitor board/fan assembly into the unit, ensuring that connectors H and J are re-connected during the process. Secure the capacitor board using the four screws (G) previously removed.
10. Lay the instrument on its left side, and re-fit the jacking screws (F) and associated plastic washers.
11. Re-fit the front panel, ensuring that the jacking screws are correctly located and that the ribbon cable connection is re-made.
12. Refit the right hand side plate, and secure the whole unit using screws A, B and C, previously removed.

## BATTERY FITTING

**Note:** Replacing the internal battery causes Real-time clock data to be lost.

### PROCEDURE

1. Remove the relevant processor module from the backplane, as shown on page 2.
2. Undo the six Torx-headed screws (B and C in figure3) which secure the right-hand side cover to the front and back plates, and remove the right-hand side cover.
3. The location of the battery (on the capacitor board) is as shown in figures 3 and 4.
4. Ensure, when fitting the battery that it is oriented correctly (as shown in figure 4), or the RTC data will not be retained.
5. Dispose of exhausted batteries according to local regulations regarding Lithium thionyl chloride batteries.
6. Re-fit the right-hand side plate using screws B and C previously removed.
7. Re-fit the module to the backplane and use the jacking screws to secure it. Ensure that the connector is correctly mated before tightening the screws, a few turns at a time each, to a final torque of not more than 2.5 Nm.

## REPLACEMENT PROCEDURES

### CHASSIS FAN FILTER REPLACEMENT

Refer to figure 2 as necessary.

1. Remove the relevant processor module from the backplane, as shown on page 2.
2. Turn the unit upside-down, so that the filter inlet is accessible.
3. Unclip the cover to reveal the filter.
4. Replace the filter, and refit the cover, ensuring that the slightly embossed face is towards the filter (i.e. the smooth side faces outwards).
5. Re-fit the module to the backplane and secure using the jacking screws. Ensure that the connector is correctly mated before tightening the screws, a few turns at a time each, to a final torque of not more than 2.5 Nm.

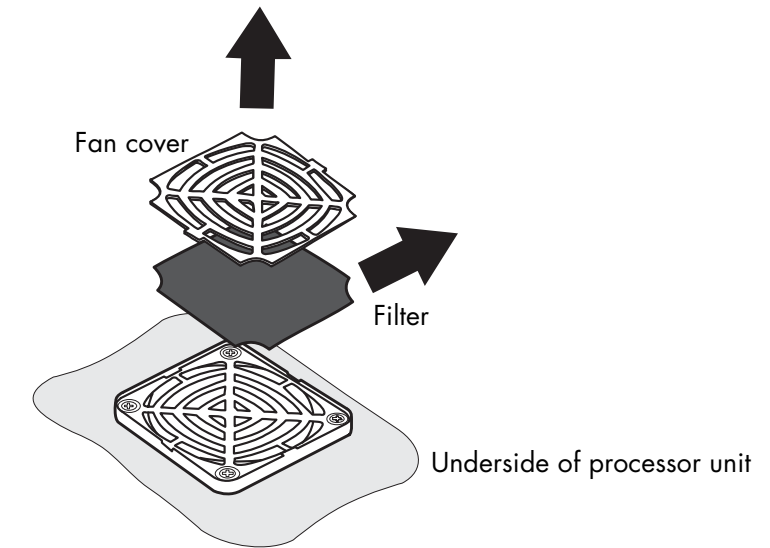

Figure 2 Filter replacement (view on underside of processor module)

**REPLACEMENT PROCEDURES (Cont.)**

Figure 3 Processor module - part explosion

**CHASSIS FAN REPLACEMENT**

**Note:** When fitting the fan, ensure that it is oriented correctly, with the air-flow direction arrow pointing away from the filter - i.e., the airflow is into the unit. The arrow is to be found on the edge of the fan body, adjacent to the wire aperture.

1. Remove the relevant processor module from the backplane, as shown on page 2
2. Undo the six Torx-headed screws (B and C) which secure the right-hand side cover to the front and back plates, and remove the right-hand side cover.
3. Lay the module on its left-hand side, and slide the lower panel (containing the external fan) out, disconnecting the fan connector ('D' in figure 3 above) as it becomes accessible.
4. Undo the four 4mm (7mm AF) fan securing nuts ('E'), and ensuring all fixings are retained, remove the nuts and washers, and lift the fan off its studs and discard it.
5. Make a visual inspection of the unit, and remove any deposits of dirt or dust using a low-pressure compressed 'air duster' such as are available from most electronics distributors.
6. Replacing all the washers previously removed, fit the new fan and secure it using the M4 nuts ('E').
7. Ensuring that the fan cable harness is not damaged in the process, slide the lower panel back into place, remembering to re-make connector 'D'.
8. Re-fit the right-hand side plate using the screws previously removed.
9. Re-fit the module to the backplane and use the jacking screws to secure it. Ensure that the connector is correctly mated before tightening the screws, a few turns at a time each, to a final torque of not more than 2.5 Nm.

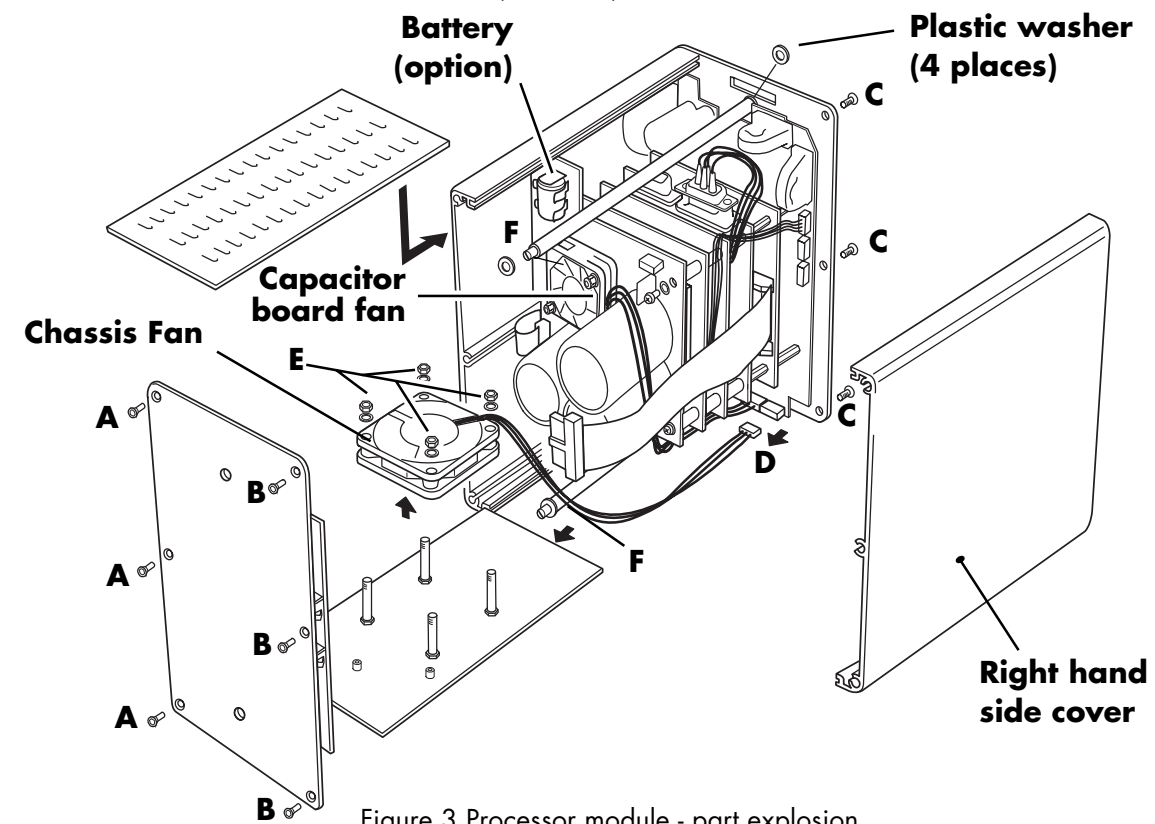
**CAPACITOR BOARD / CAPACITOR BOARD FAN REPLACEMENT**

Figure 4 Capacitor board fan access

**Note:** When fitting the fan, ensure that the air-flow direction arrow points towards the circuit board. The arrow is to be found on the edge of the fan body, adjacent to the wire aperture.

**Caution**

Ensure that the fan securing screws (K) are oriented as shown in figure 3, above, with their heads bearing on the circuit board, and the associated clamping nuts bearing on the fan body. Incorrect screw orientation will result in damage to the central processing unit on the CPU board.

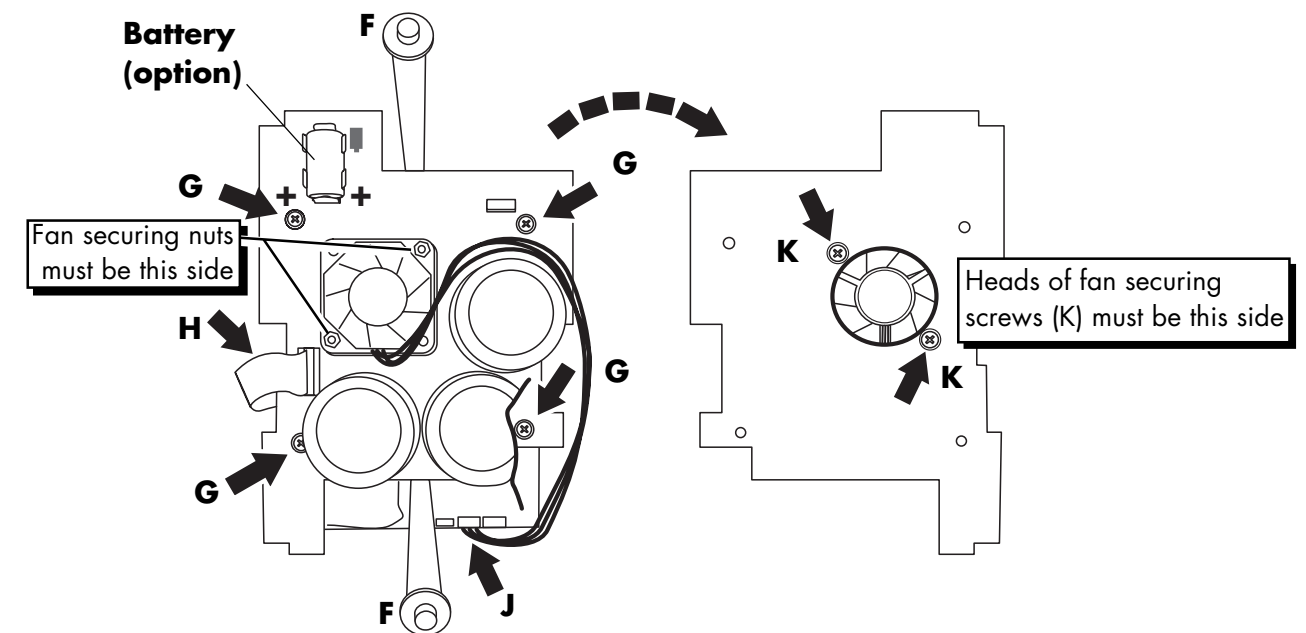
1. Remove the relevant processor module from the backplane, as shown on page 2.
2. Undo the six Torx-headed screws 'B' and 'C' (2) and remove the right-hand side cover.
3. Undo the three Torx-headed screws 'A' and carefully remove the front panel, releasing the ribbon cable connector as it becomes accessible. Place the front panel in a static-safe environment.
4. Remove the jacking screws 'F' and place them to one side for later use in re-assembly.
5. Remove the four securing screws 'G', and carefully remove the capacitor board, disconnecting the ribbon cable connector (H) and the fan connector (J) when accessible.
6. Removed the fan by undoing the two M3 nuts and bolts (K) that secure it to the circuit board.

**To replace the fan only, continue at step 7. To replace the capacitor board only, continue at step 8.**

7. Discard the old fan and fit the new one to the board, using the fixings (K) previously removed ensuring correct orientation of both fan and fixings as described in the note and caution above. Continue at step 9.