

---

# REMIO

## Communication interface for the TE range of power units

Logic version:  
'On/Off' operation

Communication protocols:

Modbus®  
Profibus-DP  
DeviceNet™

User  
Manual

© Copyright Eurotherm 1998

All rights reserved. All reproduction or transmission in any form whatsoever and using any procedure (electronic or mechanical, including photocopying and recording) without written permission from Eurotherm is strictly prohibited.

---

Ref : HA175726 ENG - Issue 2.2 - 09/2000

i

**CONTENTS**

**Applicable European Directives . . . . .iii**

**Chapter 1 Interface identification . . . . .1-1**

**Chapter 2 Wiring . . . . .2-1**

**Chapter 3 Communication . . . . .3-1**

**Chapter 4 Configuration . . . . .4-1**

**Chapter 5 Operation . . . . .5-1**

**Eurotherm addresses . . . . .5-6**

## APPLICABLE EUROPEAN DIRECTIVES

### SAFETY

**REMIO** products are not affected by the European Low Voltage Directive 73/23 EEC dated 19/02/73 (modified by Directive 93/68 EEC dated 22/07/93).

### ELECTROMAGNETIC COMPATIBILITY (EMC)

Electromagnetic compatibility is defined for industrial environments only, not for domestic environments.

Eurotherm certifies that **REMIO** products installed and used in compliance with this user manual are certified compliant with the following EMC test standards. A system incorporating these products may be certified compliant with the EMC Directive as far as **REMIO** products are concerned.

#### EMC test standards

Immunity	Generic standard:	EN 50082-2
	Test standards:	EN 61000-4-2, EN 61000-4-4, EN 61000-4-3, EN 61000-4-6, ENV 50204
Emission	Generic standard:	EN 50081-2
	Radiated:	EN 55011 Class A

#### EMC guide

In order to help you reduce the effects of electromagnetic interference associated with the installation of the product, Eurotherm Automation can supply you with an 'Electromagnetic Compatibility' guide (Ref. HA 025464).

This guide lists best practices generally applied for EMC.

### VALIDATION BY INDEPENDENT BODY

Eurotherm Automation has validated the compliance of **REMIO** products with the European Low Voltage Directive and EMC test standards through product design and laboratory testing.

---

## Personnel

The REMIO interface must be installed, configured, commissioned and maintained only by qualified staff authorised to work on low voltage electrical industrial facilities.

## Independent alarm

It is the user's responsibility to fit an independent safety mechanism which must be inspected regularly. This is highly recommended given the value of the equipment controlled by REMIO and power units.

Eurotherm can supply various types of alarm device.

## Further information

For any further information or if in doubt please contact your local Eurotherm office where qualified staff are available to advise you or assist with commissioning your facility.

## Chapter 1

### REMIO INTERFACE IDENTIFICATION

	Page
General presentation .....	1-2
Front panel .....	1-4
Technical specifications .....	1-7
Ordering code .....	1-9
Choice of modules .....	1-10
Example ordering code .....	1-10
Identification label .....	1-10

Identification

# Chapter 1 INTERFACE IDENTIFICATION

## GENERAL PRESENTATION

The **REMIO** communication interface is designed to control **several** TE series power units using a digital communication bus.

This manual describes how to use the **Logic** version of REMIO interfaces ('On/Off' operation) with three communication protocols:

**Modbus**®, **Profibus-DP**, **DeviceNet**™

The REMIO/Digital interface **receives** instructions over the communication bus and **transmits** them, in the form of logic commands, to the power units which it controls.

REMIO is a **modular** product comprising:

- a **Base Module**
- two **Optional Modules** (extension modules)

The base module provides communication bus and power supply connections as well as configuration.

In the **Logic** version each module (base module and extension modules) comprises:

- one **non-configurable port** with **8 outputs** to transmit the instructions received on the communication bus to the power units in the form of logic commands.
- one **configurable port** with **8 logic outputs** or **8 logic inputs**.

The maximum number of REMIO **outputs** with two extension modules is **48**.

The maximum number of REMIO **inputs** with two extension modules is **24** (in which case the configuration has **24** outputs).

LEDs on the REMIO front panel indicate the state of the communications bus, the presence of the module power supply and the configuration of the configurable ports.

REMIO units are mounted on symmetrical DIN rails.

The operation of the communication bus is explained in detail in the following manuals:

- 'REMIO/Modbus. Communication manual' (ref. HA 175814 ENG)
- 'REMIO/Profibus-DP. Communication manual' (ref. HA 176078 ENG)
- 'REMIO/DeviceNet. Communication manual' (ref. HA 176272 ENG).

The operation of the Eurotherm TE series of power units controlled by REMIO is described in the following user manuals:

- TE10S (ref. HA 174780ENG)
- TE10S/plf (ref. HA 174784 ENG)
- TE200S (ref. HA 175921 ENG)
- TE300 (ref. HA 175437 ENG).

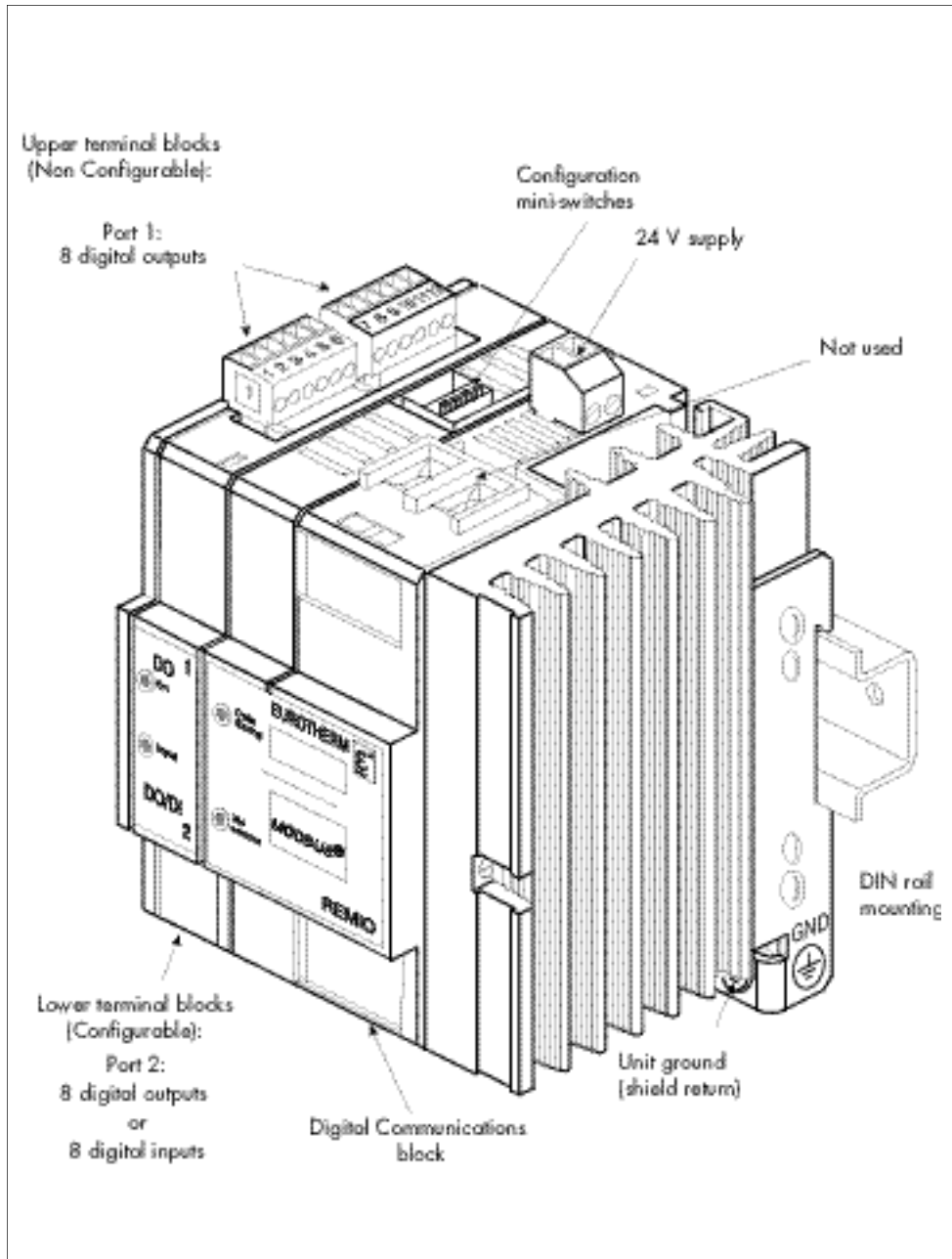

Figure 1-1 General view of REMIO/Logic base module (Modbus protocol)

Identification

**FRONT PANEL**

The diagrams below show:

- the front panels of REMIO/Logic units in various physical configurations
  - without optional modules: Base Module version
  - with optional modules (maximal configuration)
- the front panel labels for the protocols used.

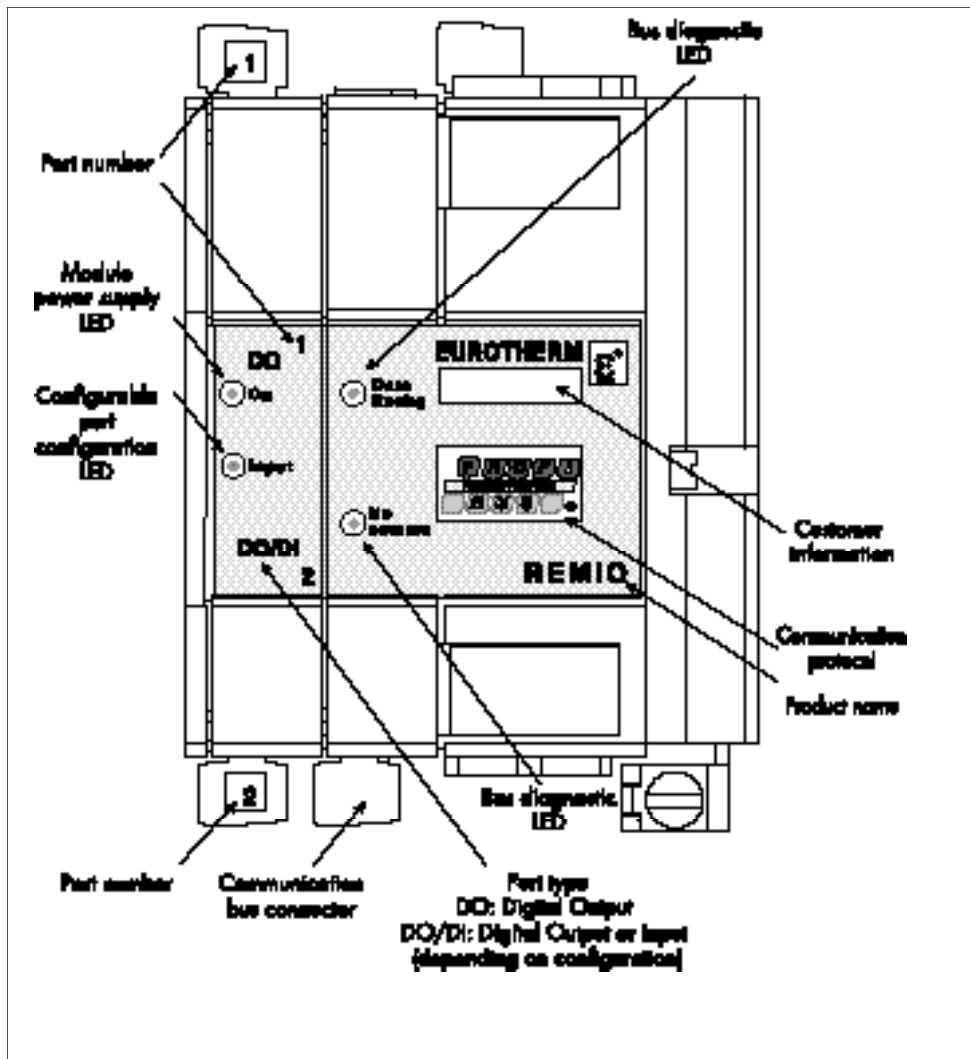

Figure 1-2 REMIO/Logic Base Module front panel (Profibus protocol)

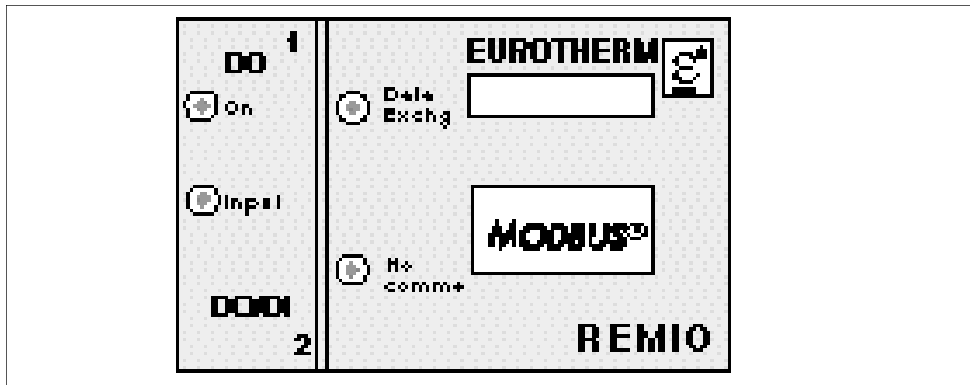

Figure 1-3A REMIO/Logic Base Module label with Modbus® protocol

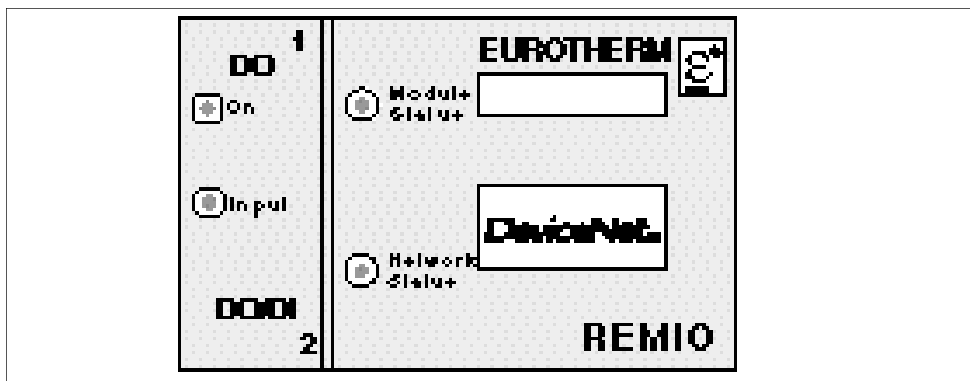

Figure 1-3B REMIO/Logic Base Module label with DeviceNet™ protocol

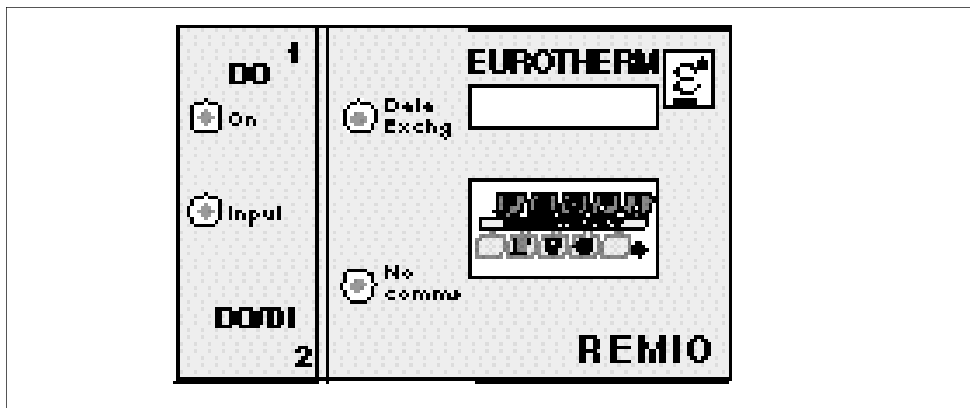

Figure 1-3C REMIO/Logic Base Module label with Profibus-DP protocol

Identification

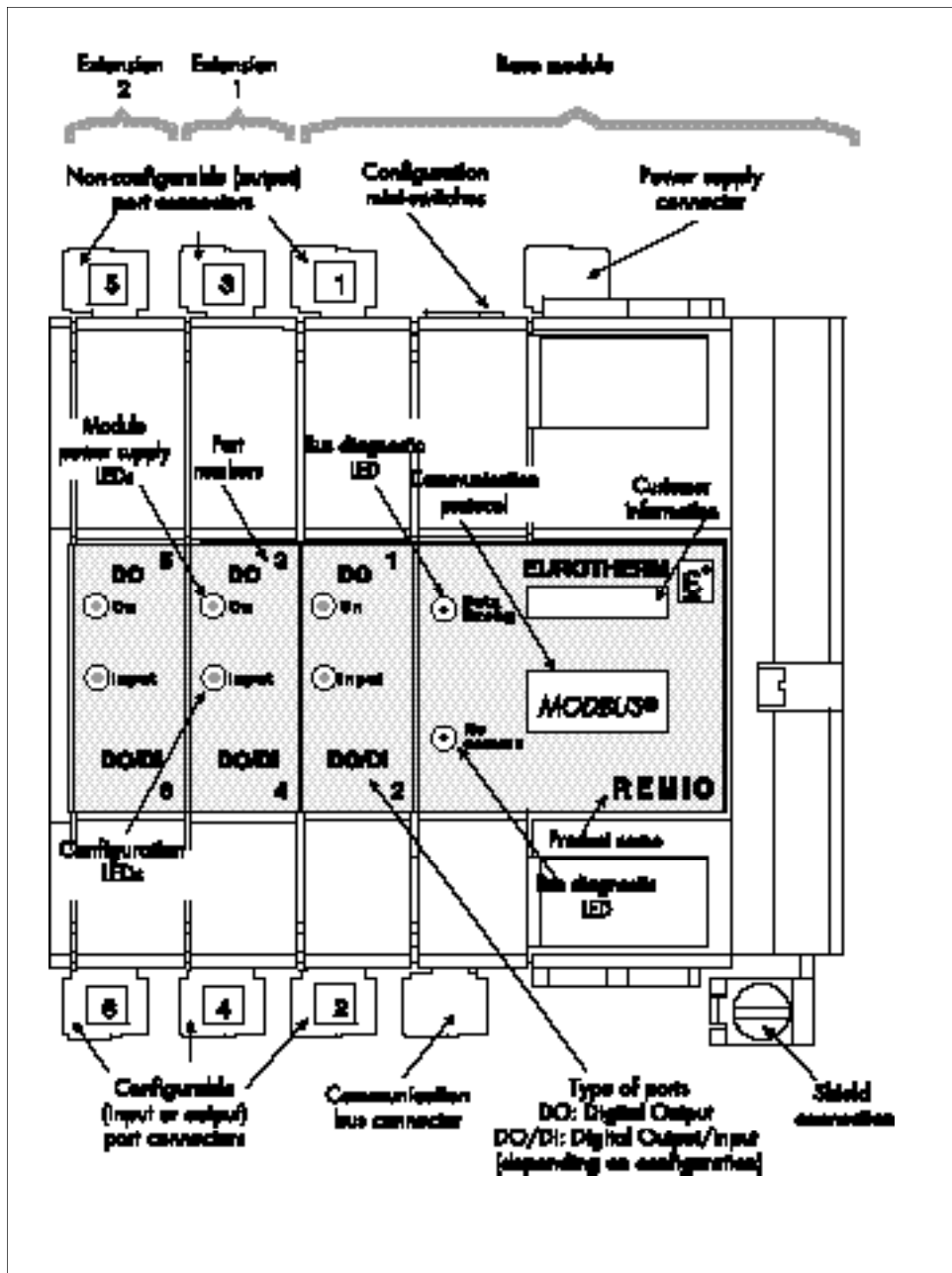

Figure 1-4 REMIO/Logic front panel (Modbus protocol) in maximum configuration (48 outputs)

## TECHNICAL SPECIFICATIONS

The REMIO communication interface is designed to drive several thyristor units controlling resistive industrial loads or shortwave infrared elements.

### Physical configuration

Base module	One non-configurable port with 8 digital outputs and one configurable port (8 digital outputs or 8 digital inputs). Configuration mini-switches
Extensions 1 or 2	Power supply and communications bus connectors. One non-configurable port with 8 digital outputs and one port with the same functions as the base module (8 digital outputs or 8 digital inputs).
Maximum number of inputs/outputs	48 outputs or 24 outputs and 24 inputs.

### Port specification

Output	20 V logic signal. Maximum current limited to 6.5 mA. It is possible to connect the inputs of two TE series solid state relays in series on each REMIO output.
Input	Logic signal or contact (max. 6.5 mA).
Common excitation voltage	A common +20 Vdc supply is available for all inputs/outputs on each port.
Connectors	Plug-in. Max. wire cross-section: 1.5 mm <sup>2</sup> Clamping torque: 0.25 Nm.

### Communication

Communication protocol	Modbus®, Profibus-DP or DeviceNet™ (specify when ordering).
Bus	2-wire RS485 (Modbus® or Profibus) or CAN Bus (DeviceNet™)
Transmission rate	Modbus®: 9.6 or 19.2 kbaud (configurable) Profibus-DP: auto baud rate detection up to 1.5 Mbaud. DeviceNet™: 125, 250 or 500 kbaud (configurable).
Connector	Plug-in. Max. wire cross-section: 1.5 mm <sup>2</sup> Clamping torque 0.25 Nm.

### Diagnostics

Communications	State of communications bus and inputs/outputs.
Diagnostic LEDs	Bus state, module power supply, active state of configurable ports (inputs).

### Power supply

Voltage (TBTS)	24 Vdc non polarised (-15%, +25%) or 24 Vac (-15%, +10%); 47 to 63 Hz
Connector	Plug-in. Max. wire cross-section: 1.5 mm <sup>2</sup> Clamping torque: 0.25 Nm.
Consumption	Depends on number of outputs used (max. 20 VA).

Identification

### Thyristor firing

General	All outputs control 'On/Off' firing of the solid state relays driven.
Switching	Zero-crossing firing and ending is controlled by the electronics in the thyristor units.

### Environment

Operating temperature	0°C to +45°C at max. altitude 2000 m
Storage temperature	-10°C to +70°C
Power supply circuit protection	External 2 A fuse
External wiring	Must comply with IEC 364
Operating atmosphere	Non-explosive, non-corrosive and non-conductive
Humidity	RH 5% to 95% with no condensation or streaming
Pollution	Pollution degree 2 permissible, as defined by IEC 664.

### Physical dimensions

Dimensions (mm)	Height: 115 (122 including connectors) Depth: 92.5 Width: Base module = 87.5 One optional model = 17.5 Maximum configuration = 122.5
Weight (kg)	0.9 (maximum physical configuration).
Mounting	Leave gap of 2 cm between adjacement units.

#### Warning!



EUROTHERM has taken particular care to ensure that these specifications are correct. However, in order to maintain our 'leading edge' we continually strive to improve our products, which may lead to modifications or omissions in the specifications. We shall not be held responsible for any damage, injury, losses or expenses incurred as a result of such modifications.

Please contact your local Eurotherm office for any further information or if in doubt.

## ORDERING CODE

**REMIO/Base Module/Ext.1/Ext.2/Protocol/Transmission rate/Manual//00**

Base Module	Code
16 digital outputs or 8 digital outputs and 8 digital inputs	<b>D</b>

Extension module 1	Code
Extension 1 present (16 digital outputs or 8 digital outputs and 8 digital inputs)	<b>D</b>
Without extension 1	<b>-</b>

Extension module 2	Code
Extension 2 present (16 digital outputs or 8 digital outputs and 8 digital inputs) extension 1 must be present	<b>D</b>
Without extension 1 or 2	<b>-</b>

Communications protocol	Code
Modbus®	<b>MOP</b>
Profibus-DP	<b>PFP</b>
DeviceNet™	<b>DNP</b>

Transmission rate	Code
Modbus: 9.6 kbaud	<b>96</b>
19.2 kbaud	<b>192</b>
Profibus-DP (auto baud rate detection)	<b>AUTO</b>
DeviceNet: 125 kbaud	<b>125</b>
250 kbaud	<b>250</b>
500 kbaud	<b>500</b>

Manual language	Code
French	<b>FRA</b>
English	<b>ENG</b>

Identification

**MODULE SELECTION**

Number of outputs	Number of inputs	Base Module	1 Extension Module	2 Extension Modules	Configurable ports
1 to 16 17 to 32 33 to 48	0 0 0	Yes Yes Yes	- Yes Yes	- - Yes	Outputs: factory configuration
1 to 8 9 to 16 17 to 24	1 to 8 1 to 16 1 to 24	Yes Yes Yes	- Yes Yes	- - Yes	Inputs: Reconfiguration by user

Table 1-1 Possible physical configurations

**EXAMPLE ORDERING CODE**

Number of TE10S solid state relays driven by REMIO: 15  
 Number of PLF alarm contacts for which the status is signalled to the Master via REMIO inputs: 3  
 Physical configuration of REMIO according to table 1-1:  
 Base module + 1 extension module  
 Configurable ports configured as inputs

Communication used            Modbus at 9600 baud  
 User manual                    English

**Ordering code: REMIO / D / D / - / MOP / 96 / ENG // 00**

**IDENTIFICATION LABEL**

An identification label gives full details of the REMIO unit's characteristics when it left the factory. The identification label is located on the left hand side of the unit.



Figure 1-5 Example of REMIO identification label (corresponds to example ordering code above)



**Caution!**  
 If the unit has been reconfigured by the user it may no longer correspond to the information shown on the label.

# Chapter 2

## WIRING

	Page
Safety during installation . . . . .	2-2
Safety during wiring . . . . .	2-2
Description of terminal blocks . . . . .	2-3
Control terminal blocks . . . . .	2-3
Output wiring . . . . .	2-8
Input wiring . . . . .	2-9
Power supply . . . . .	2-9
Communications bus . . . . .	2-10
Terminal block . . . . .	2-10
Wiring . . . . .	2-10
Control cable shielding . . . . .	2-12
Typical REMIO / TE wiring . . . . .	2-13

## Chapter 2 WIRING

### SAFETY DURING INSTALLATION

#### Danger!



REMIO units must be installed and wired by qualified staff authorised to work on low voltage industrial electrical facilities.

Units must be installed in a fan-cooled cabinet, to ensure that condensation and pollution are excluded. The cabinet must be closed and connected to the protective earth according to IEC 364 or applicable national standards.

We recommend fitting the fan-cooled cabinet with a fan failure detection device or a thermal safety cut-out.

#### Caution!



REMIO units are designed to be mounted on DIN rails, with the heatsink positioned vertically, and with no obstructions above or below the unit which could reduce or hamper air flow.

Leave a minimum gap of 2cm between two adjacent units.

The temperature of the heatsink may reach 85°C. Avoid touching the heatsink even briefly when the unit is operating. The heatsink remains hot for approximately 15 minutes after the unit is switched off.

### SAFETY DURING WIRING

#### Danger!



It is the user's responsibility to wire and protect the facility according to best practice and applicable standards

Before connecting or disconnecting the unit check that power and control cables and leads are isolated from voltage sources.

#### Caution!



The REMIO earthing screw, labelled



must be connected to the cabinet's reference ground plane.

To ensure that the REMIO units are correctly earthed, according to the European 'Electromagnetic Compatibility' directive, ensure that the unit's ground is correctly connected to the reference ground plane (cabinet panel or bulkhead).

If this is not possible, add a ground connection with a maximum length of 10 cm between the earth connection and the reference ground plane.

## DESCRIPTION OF TERMINAL BLOCKS

The REMIO communications interface comprises the following terminal blocks.

- control terminal blocks (2 blocks of 6 terminals for each port)
- power supply terminal block
- communications bus terminal block

All connectors are **plug-in** units.

The terminals of the **control** and **communications bus** terminal blocks are suitable for conductors up to **1.5 mm<sup>2</sup>**. The clamping torque is **0.25 Nm**.

The terminals of the **supply** terminal block are suitable for conductors up to **2.5 mm<sup>2</sup>**. The clamping torque is **0.5 Nm**.

### Control terminal blocks

Each control port has **two** terminal blocks (two plug-in connectors).

Each control terminal block has six terminals (see figures 2-1 to 2-4), as follows:

- **4** output or input terminals (terminal numbers **2 to 5** and **8 to 11**)
- **2** 'common +20 Vdc' terminals (terminal numbers **1, 6** and **7, 12**).

Module type	Port number	Terminal numbers	Digital input/output numbers	
Base module	1	2 to 5 8 to 11	1 to 4 5 to 8	Outputs
	2	2 to 5 8 to 11	9 to 12 13 to 16	Inputs or outputs
First optional module	3	2 to 5 8 to 11	17 to 20 21 to 24	Outputs
	4	2 to 5 8 to 11	25 to 28 29 to 32	Inputs or outputs
Second optional module	5	2 to 5 8 to 11	33 to 36 37 to 40	Outputs
	6	2 to 5 8 to 11	41 to 44 45 to 48	Inputs or outputs
All types	1 to 6	1, 6, 7 and 12	Common +20Vdc	

Table 2-1 Control terminal functions

**Reminder:** The maximum current for each output or input is **6.5 mA**.

Wiring

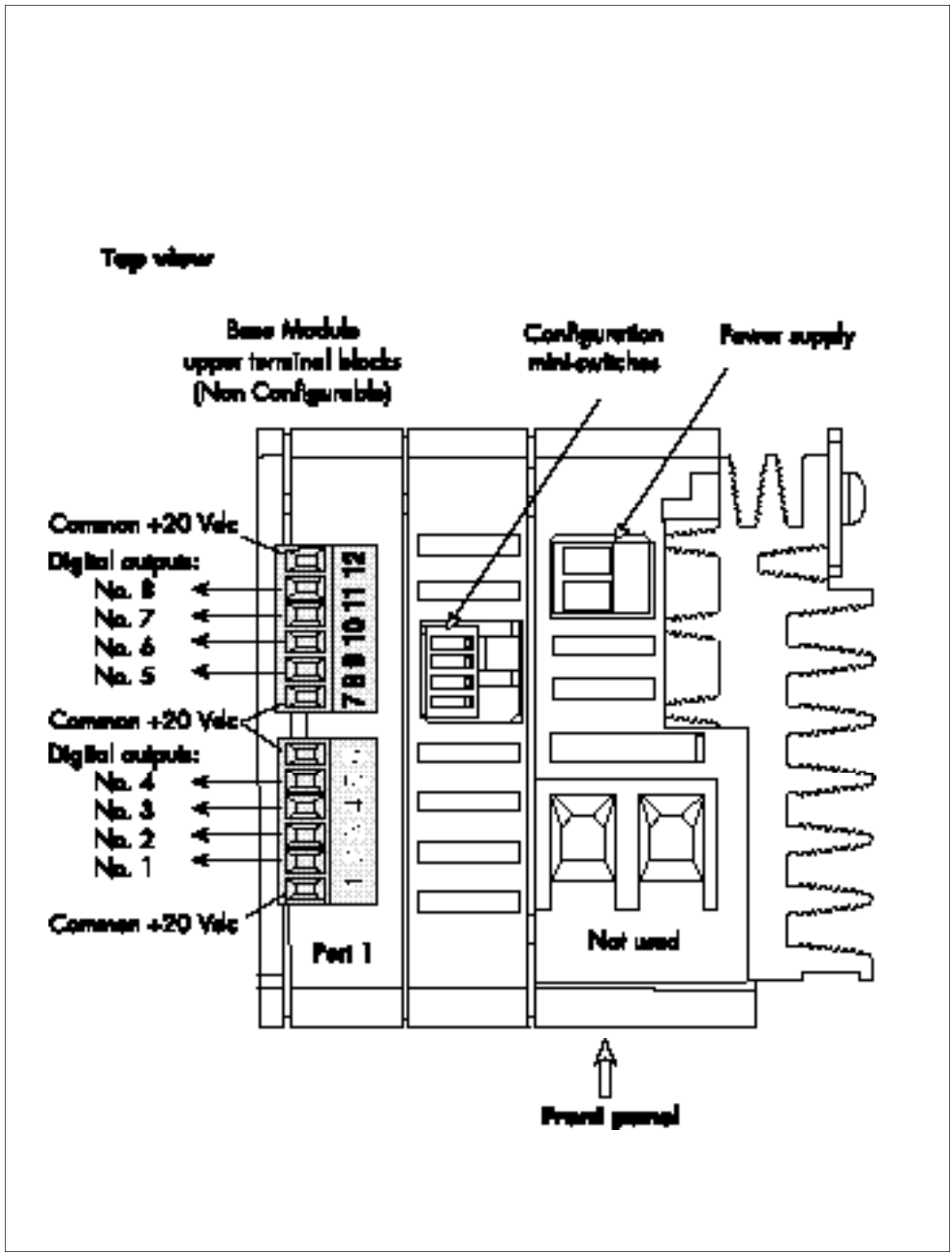

Figure 2-1 Base module control terminal identification (upper terminal blocks)

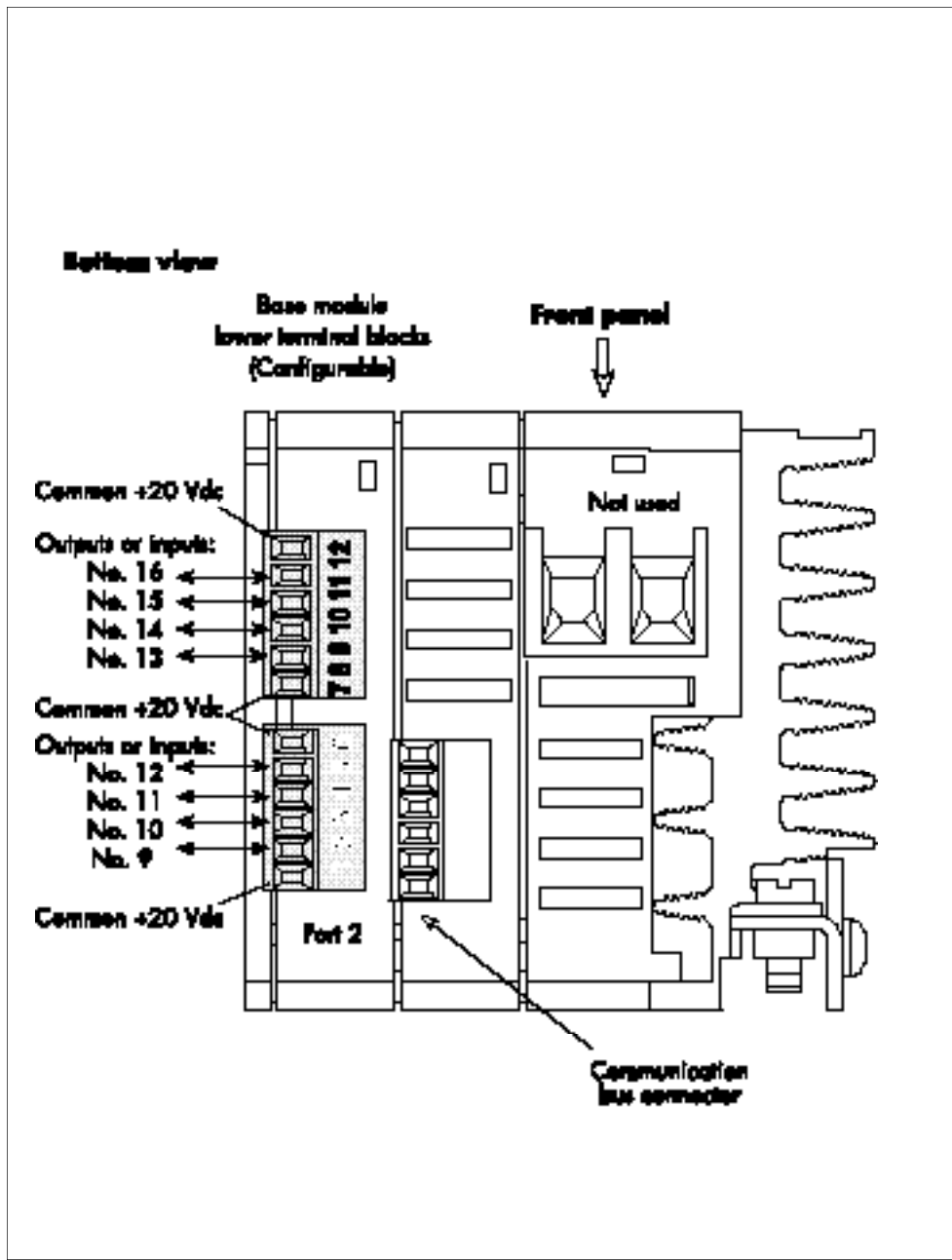

Figure 2-2 Base module control terminal identification (lower terminal blocks)

Wiring

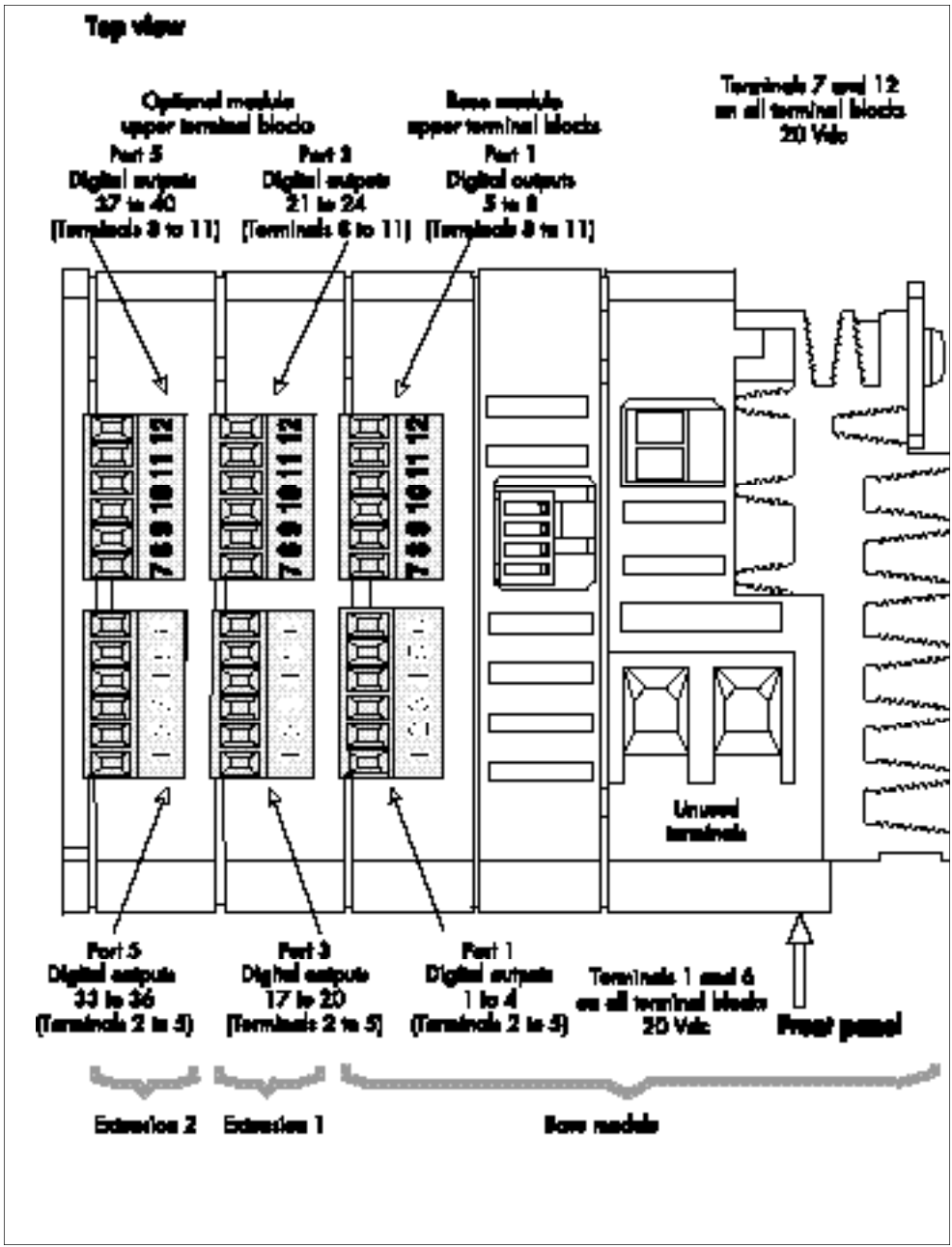

Figure 2-3 Control terminal block identification (2 extension modules, upper terminal blocks)

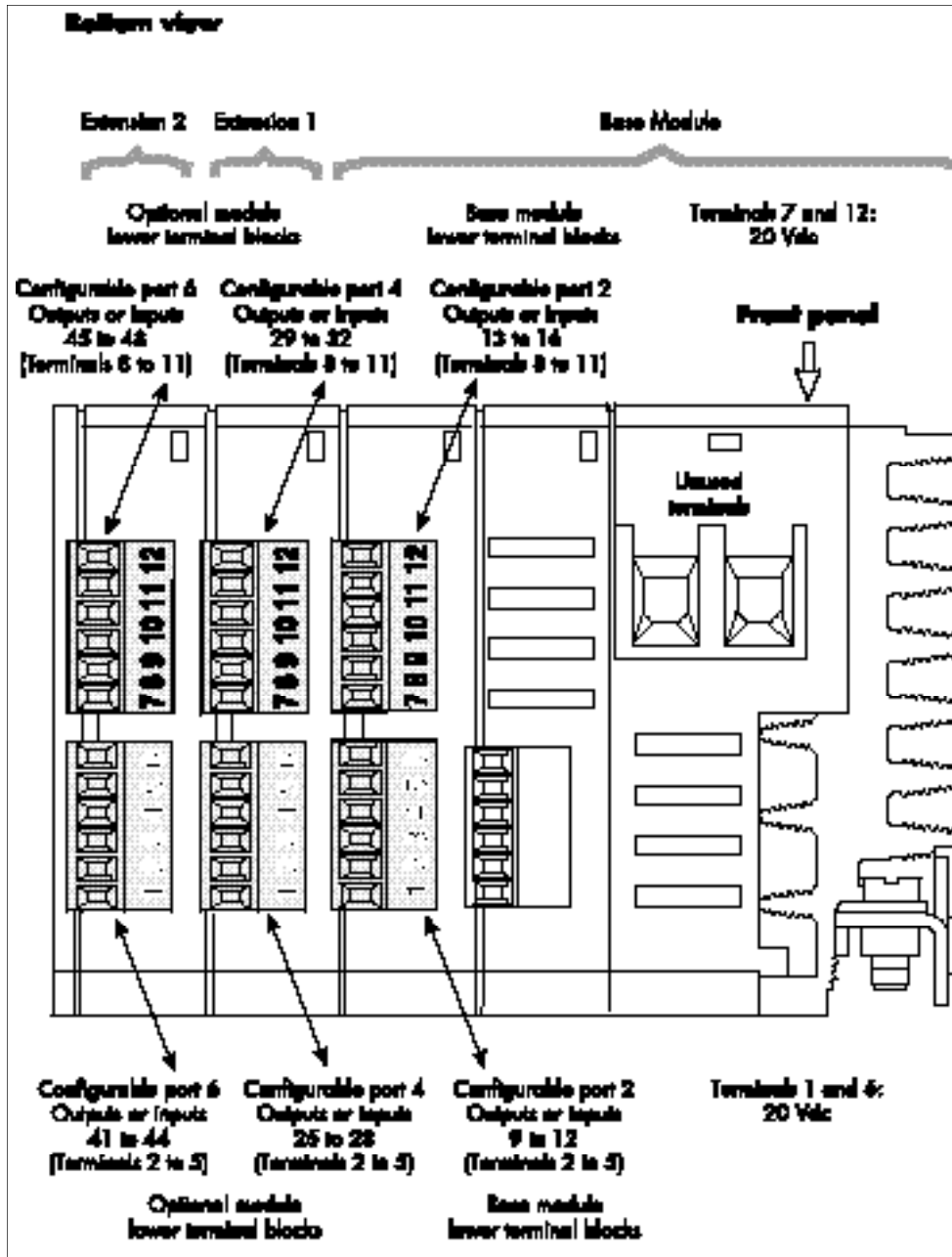

Figure 2-4 Control terminal block identification (2 extension modules, lower terminal blocks)

Wiring

**Output wiring**

The REMIO digital outputs should be connected to the DC inputs of the thyristor power units controlled (up to two TE10S solid state relays in series).

The diagram below shows an example of control wiring for two power units: two Eurotherm TE10S solid state relays (the TE10S inputs are connected in series).

The power wiring is not shown on this diagram. See the corresponding user manuals for details of how to connect the power supply and load to the thyristor units.

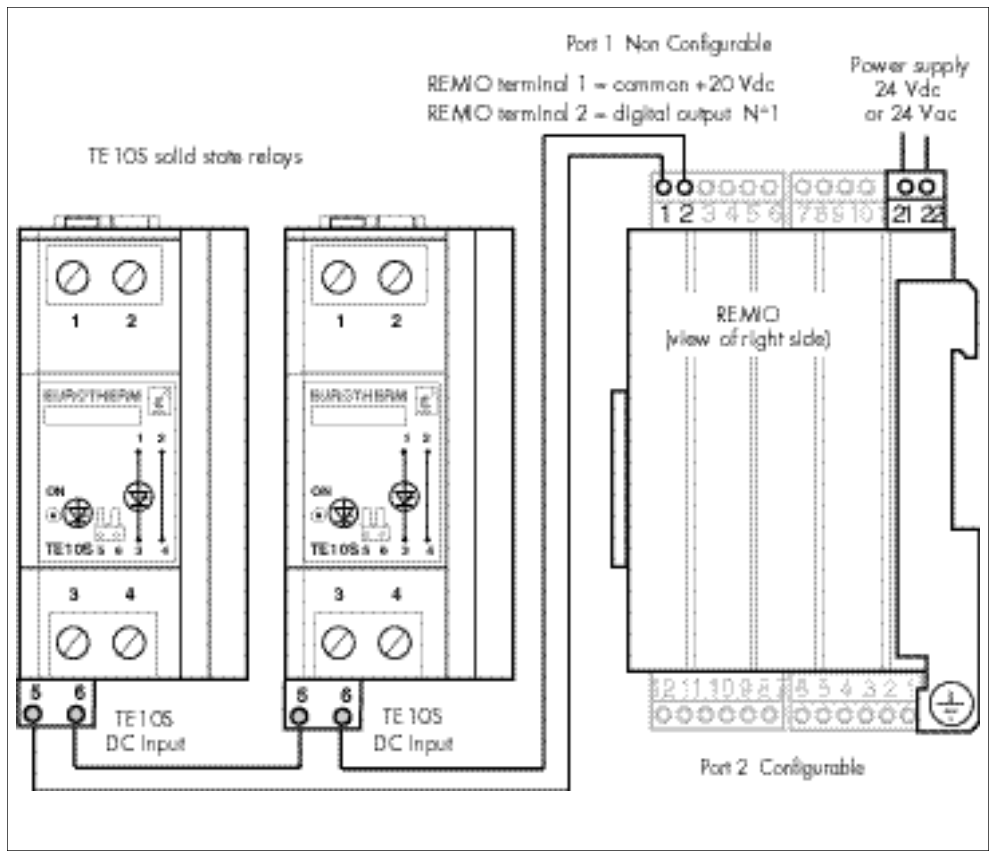

Figure 2-5 Example of control wiring for TE10S solid state relays  
(Port 1 output 1 is used on the REMIO unit)

## Input wiring

The logic signal can be applied with:

- a 'dry' **contact** (signal from a TE10S solid state relay with **PLF alarm** option)
- a **transistor** or **photocoupler** (signal from any external system).

This signal must be connected to the lower ports **configured** as inputs using the corresponding mini-switch.

The digital inputs use a **+20 Vdc common** voltage (terminals **1, 6, 7** or **12**).

The operation of the inputs (**direct** logic or **inverted** logic) is configured using digital communications (see 'Communications' and 'Operations' chapters).

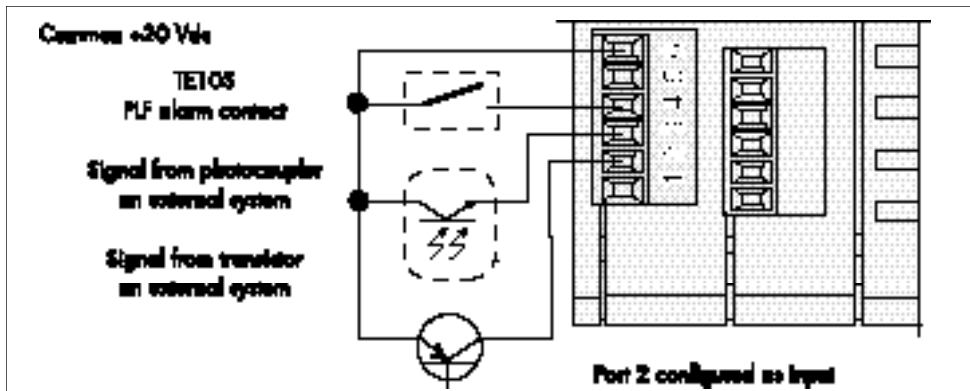

Figure 2-6 Example input wiring (seen from below)

## Power supply

The power supply terminal block (terminals **21** and **22**) is located on the top of the unit.

The voltage may be **24 Vdc non-polarised** (-15%, +25%) or **24 Vac** (-15%, +10%).

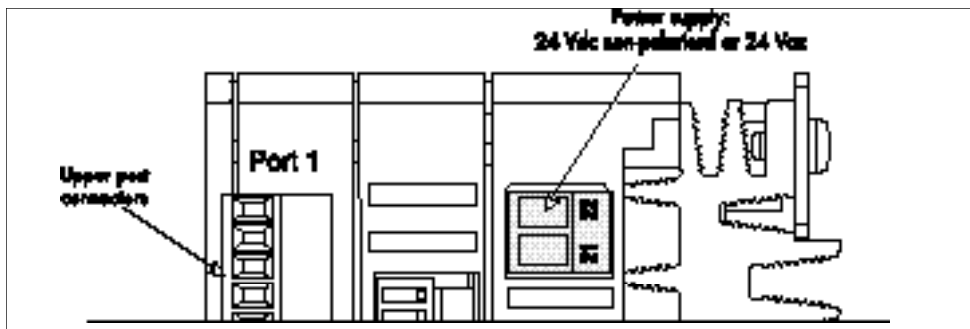

Figure 2-7 REMIO power supply terminal (seen from above)

### Caution!



A **2 A** fuse must be provided to protect the power supply connection.

## Communications bus

### Communications bus terminal block

The communications bus terminal block is located underneath the unit.

It has:

- 6 terminals, numbered from **61** to **66**, for the **Modbus** and **Profibus** protocols
- 5 terminals, numbered from **1** to **5**, for the **DeviceNet** protocol.

Terminal number	Terminal identification depending on protocol	
	Modbus	Profibus
61	RX-/TX- (B)	B
62	RX+/TX+ (A)	A
63	Not used (0V)	0V
64	RX+/TX+ (A)	A
65	RX-/TX- (B)	B
66	Not used Not connected	+5V

Table 2-2 Communications bus terminals for Modbus and Profibus protocols

#### Important!



- With the **Profibus** protocol, by convention, the potential of terminals **A** is **greater than** the potential of terminals **B** when the RS485 line is **active**.
- With the **Modbus** and **Profibus** protocols:
  - terminals **61** and **65** are **connected together** inside the unit.
  - terminals **62** and **64** are **connected together** inside the unit.

Terminal number	Terminal identification with DeviceNet protocol	
1	V- (B)	
2	CAN_L (A)	
3	Drain (not connected) (0V)	
4	CAN_H (A)	
5	V+ (B)	

Table 2-3 Communications bus terminals for DeviceNet protocol

### Communications bus wiring

To ensure **reliable operation** of the digital communications link (with no alteration of data due to noise or line reflections) the connections must use **shielded twisted pairs** with the shields **connected to ground** at both ends (see figures 2-9 and 2-10).

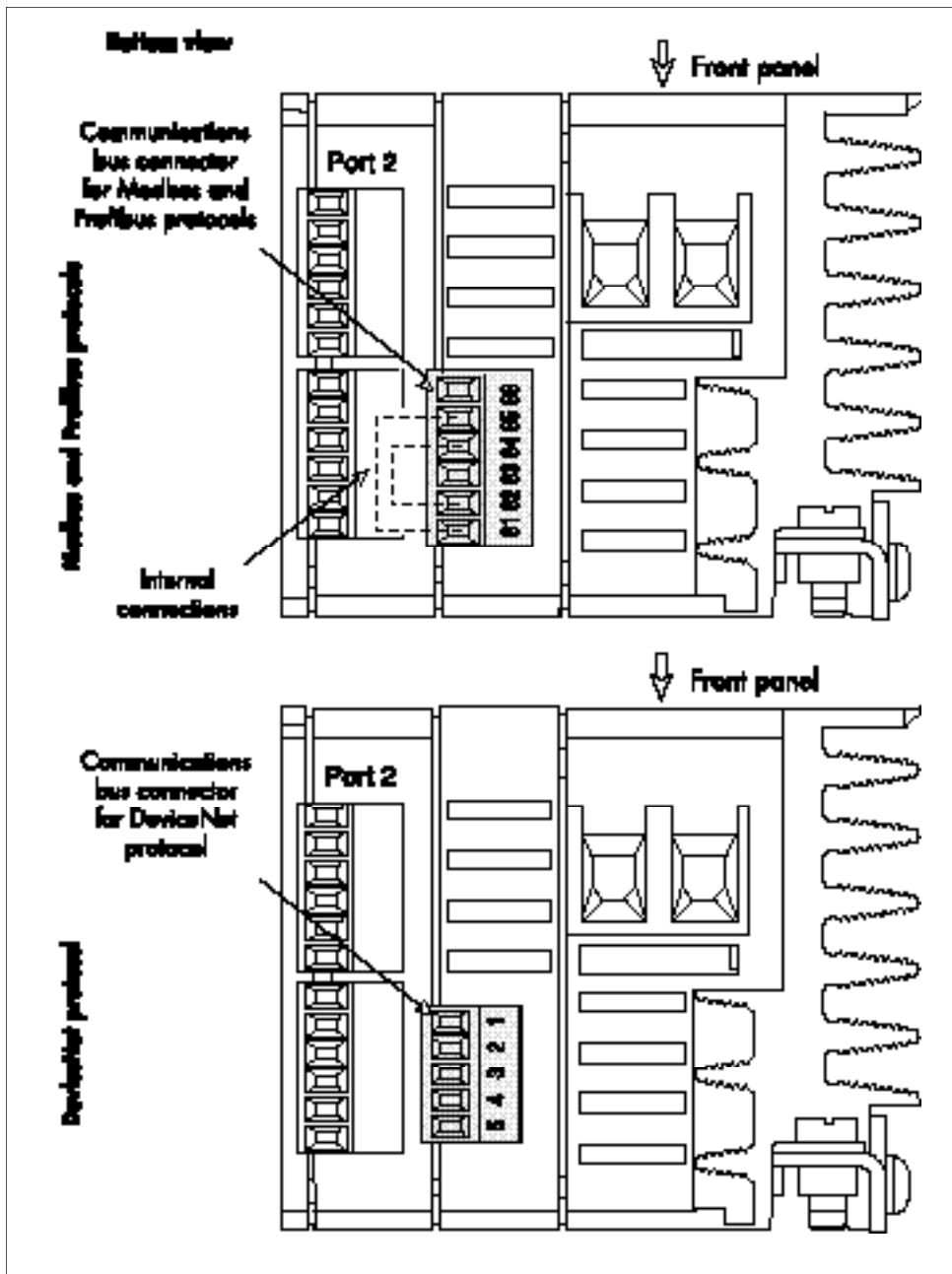

Figure 2-8 Communications bus terminal block for alternative protocols

## CONTROL CABLE SHIELDING

The control and communication bus cable shields must be **connected to ground at both ends**. A shield grounding screw is provided for this purpose on the REMIO unit.

### Important!

The unit's ground return screw should be connected to the ground plane using as short a connection as possible.

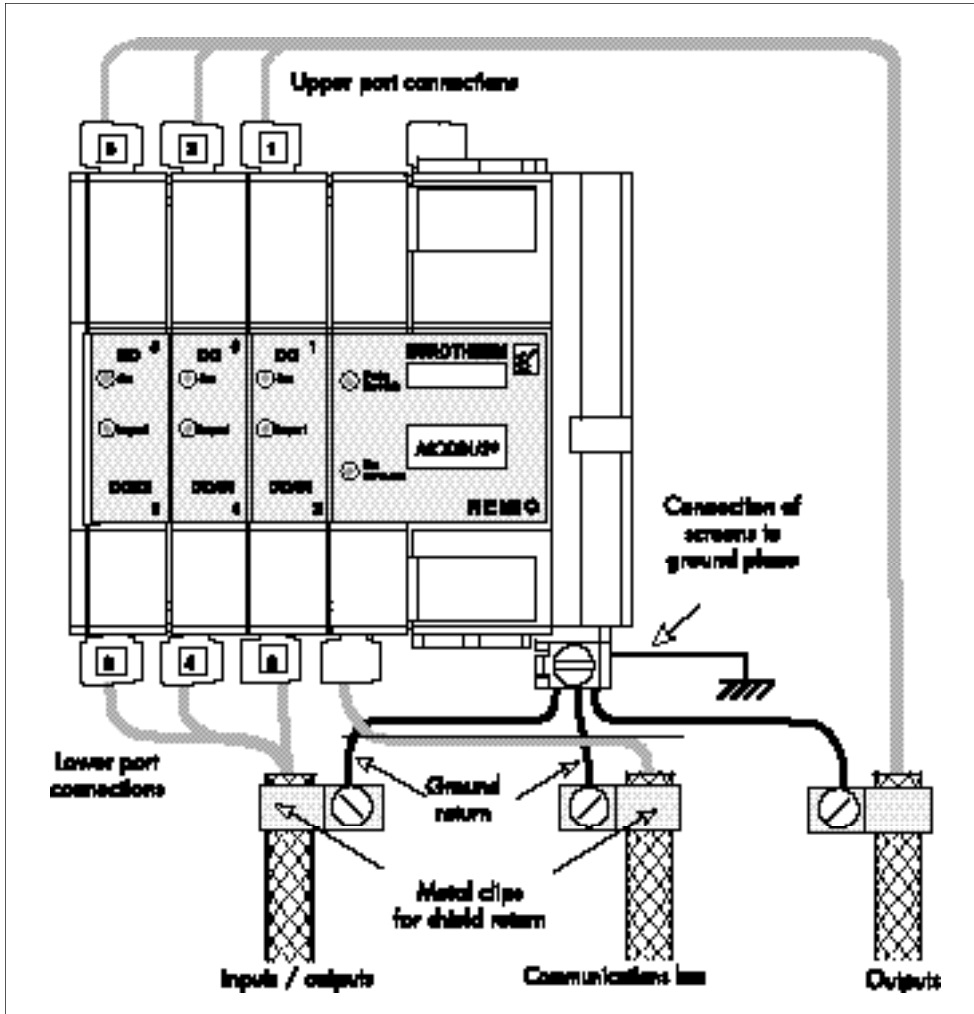

Figure 2-9 Shield grounding for control and communications wires

## TYPICAL REMIO / TE WIRING

The wiring for the REMIO interface and the power units comprises:

- REMIO ground wiring, labelled with the symbol below:



- power supply wiring
- communications bus connection
- power unit control wiring.

To ensure that the power units driven by the REMIO operate correctly with regard to **electromagnetic interference**, the REMIO outputs and inputs must be connected to the inputs and alarm contacts on the power units using **shielded cables**.

The control and communications bus cable shields must be connected to the REMIO ground as shown on figure 2-9.

Figure 2-10 gives a wiring example for a REMIO unit driving TE10S series solid state relays.

The example shows:

- two TE10S solid state relays driven by two non-configurable port outputs (base module)
- one alarm contact from a TE10S/PLF solid state relay with PLF alarm option connected to a configurable port input.

The power wiring for the TE units is not shown in figure 2-10. See the TE series user manuals for details of power wiring for thyristor units.

Wiring

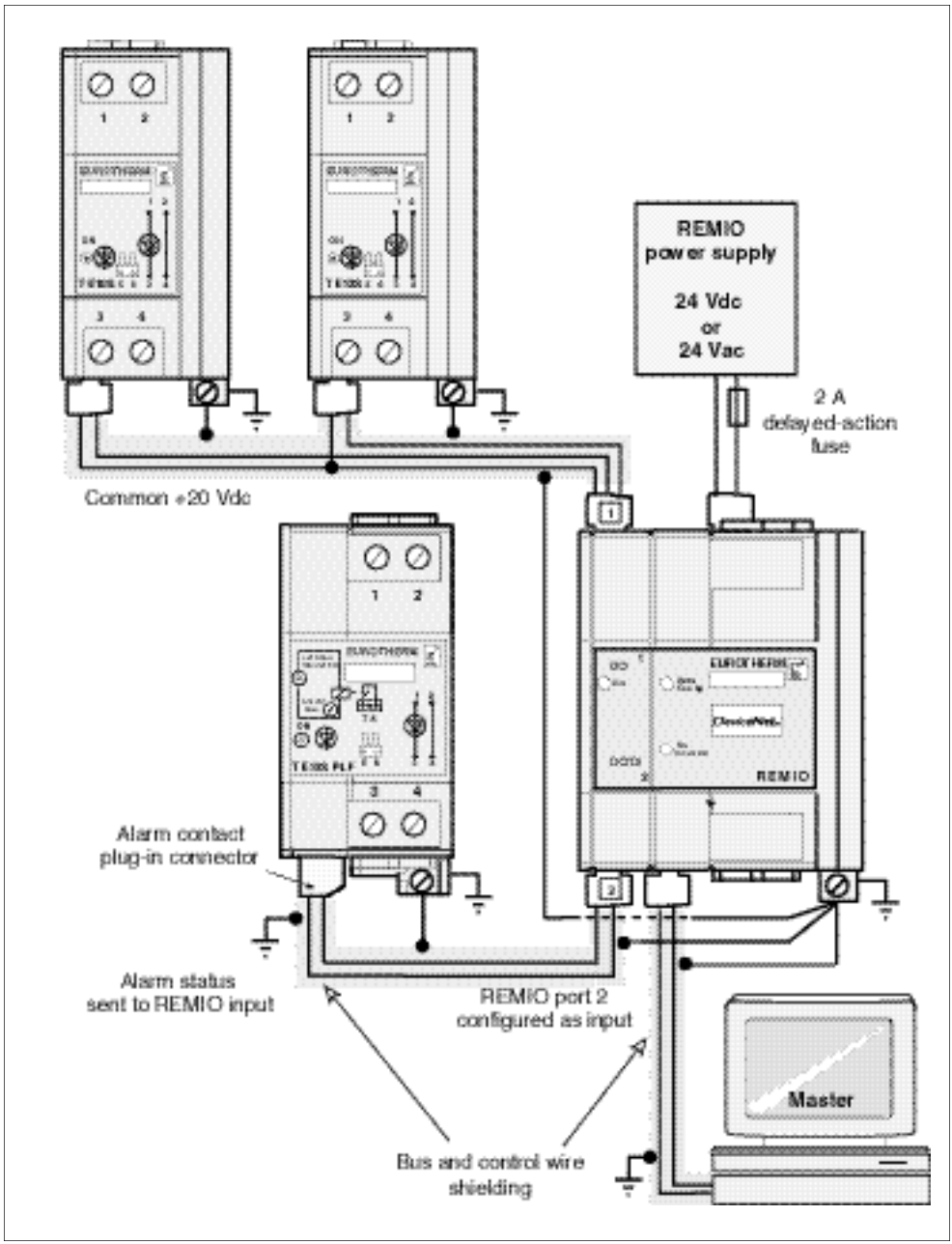

Figure 2-10 Wiring example with TE series power units driven by a REMIO/Logic base module.

# Chapter 3

## DIGITAL COMMUNICATIONS

	Page
General .....	3-2
Modbus® Protocol .....	3-3
State of ports .....	3-3
Error codes .....	3-4
Addressing .....	3-4
'Input / Output' addresses .....	3-5
Profibus-DP protocol .....	3-6
State of ports .....	3-6
Addressing .....	3-7
'Input / Output' addresses .....	3-8
State diagram .....	3-9
Power up .....	3-9
Parameter settings .....	3-9
Configuration .....	3-9
Data exchange .....	3-11
DeviceNet protocol .....	3-12
State of ports .....	3-13
Error codes .....	3-13
Addressing (identification) .....	3-14
Operating state diagram .....	3-15
Power up .....	3-15
Self test .....	3-15
Configuration .....	3-15
Operation .....	3-15
Shutdown .....	3-15

## Chapter 3 COMMUNICATIONS

### GENERAL

REMIO interfaces are equipped with digital communications as standard.

This enables four main functions to be performed:

- configuring the communications protocol parameters and operating parameters
- configuring the REMIO unit's bus address
- controlling the state of the REMIO interface
- monitoring all operating parameters.

The physical medium carrying the digital link information uses the following standards:

- **RS485** for **Profibus-DP** and **Modbus®** protocols
- **CAN** for the **DeviceNet™** protocol.

The communications bus is **isolated** from all other inputs and outputs.

**Important!** The protocol is selected when the unit is ordered and **can not be reconfigured by the user.**

Message transfers use 'Master / Slave' mode.

The REMIO interface always operates as a 'Slave', and the supervision system or PLC acts as 'Master'.

All exchanges involve a request from the master and a response from the slave.

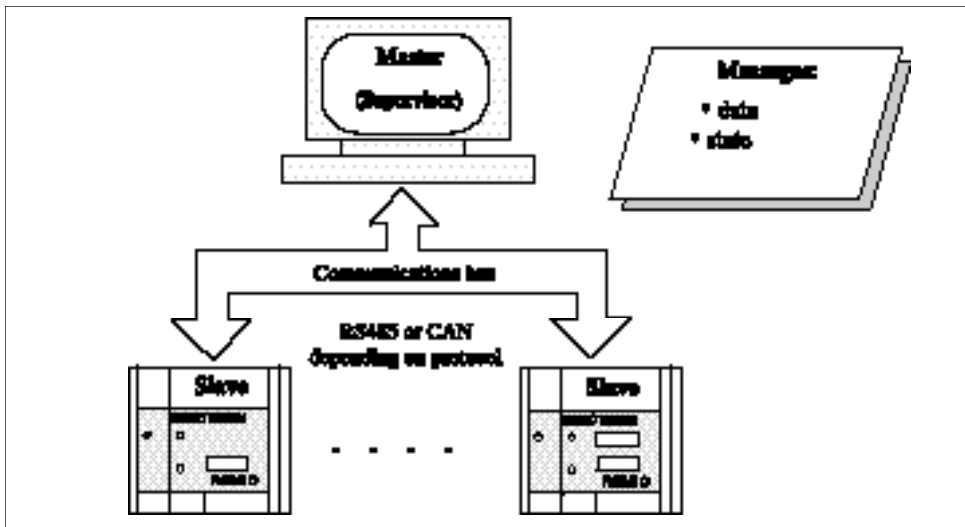

Figure 3-1 Organisation of data transfers

## MODBUS® PROTOCOL

The **Modbus®** protocol is a binary serial (or RTU) protocol.

**Important:** A detailed description of Modbus® operation is given in the 'REMIO/Modbus: Communication Manual', ref. HA175814 ENG.

Transmission frames use binary characters.  
Character format: 1 start bit - 8 data bits - 1 stop bit - no parity.

The **transmission rate** may be set using mini-switches to **9.6** or **19.2 kbaud**

The Modbus® protocol controls the transmission frame exchange cycles. Each exchange comprises two messages (Query and Response) between the Master and the Slave, except for broadcast messages where no response is sent.

The frame structure is identical for queries and responses:

- slave address (1 byte): specifies the slave concerned on the communications bus
- function code (1 byte): indicates the operation to be performed
- data (n bytes): parameters needed for the function
- CRC-16 error check (2 bytes): cyclic redundancy check.

For error responses the frame structure is as follows:

- slave address (1 byte)
- function code + 128 (1 byte)
- error code (1 byte)
- CRC-16 error check (2 bytes): cyclic redundancy check.

## State of ports

The state of the ports is stored in control word **CW**.

The **configuration type** (configurable ports only) is determined by the position of mini-switch **SW1.1**. This type (input or output) can be **read** in bit **11** of the **CW** (address **102** in the parameter list).

- Bit **11** of **CW** = **0**: the configurable ports are configured as **inputs**
- Bit **11** of **CW** = **1**: the configurable ports are configured as **outputs**.

The type of **input logic** can be **read** and **written** in bit **0** of the **CW**:

- Bit **0** of **CW** = **0**: the inputs use **direct logic**:  
the input is active (bit = 1) if a contact is **closed**.
- Bit **0** of **CW** = **1**: the inputs use **inverted logic**:  
the input is active (bit = 1) if a contact is **open**.

The port state is **common** to all the REMIO's configurable ports.

It is possible to write to several REMIO units using the broadcast function.

The control word must be modified (preferably **bit by bit** using function **5**) **before** any other operations are performed.

## Error codes

An error message frame contains 5 bytes:

- Physical address (1 byte)
- Function code (1 byte)
- Error code (1 byte)
- Checksum (2 bytes);

Error code (decimal)	Error type
1	Function forbidden
2	Data address forbidden
3	Data value outside limits
4	Device failure
5	ACK (positive acknowledgement)
6	Not used (reserved)
7	NACK (negative acknowledgement)
8	Write impossible
9	No data request
10	Too many data requests

Table 3-1 Meaning of Modbus® error codes

## Addressing

To communicate with the REMIO interface, the **Modbus®** protocol uses:

- the REMIO interface's **physical** address (address **on the bus** used)
- the addresses of each **port**

### Important!



As shipped from the factory, the REMIO interface's **default** physical address is set to: **32 (decimal)**

This address may be **reconfigured** by the user **using the digital link**.  
Ensure that there is only **one unit** at each physical address.

In normal operation, addresses **1** to **247** may be used for the the **physical address**.  
The REMIO's physical address is at internal address **100** on the list of parameters.

Each REMIO **port** is represented by one **byte**.

Each **input** or **output** is defined by **one** of the **8 bits** in the byte corresponding to the port.

The **output** addresses are accessible for **read/write** access.  
Outputs may be modified by **broadcast**.

**Input** addresses are accessible for **read** access only.

The input / output ports are at addresses **1** to **6** in the list of parameters.

The input / output logic parameters can be set to **0** or **1**.

## Input / output addresses

The table below gives:

- the output addresses (configurable ports configured as outputs)
- the input and output addresses (configurable ports configured as inputs)

Port parameter				'Input / output'logic parameter			
Module	Port	Port address	Port configuration	Terminal	Output No.	Input number	Bit No. in port byte
Base module	1	1	Non Configurable	2 to 5	1 to 4	-	0 to 3
				8 to 11	5 to 8	-	4 to 7
	2	4	Configured as inputs	2 to 5	-	9 to 12	0 to 3
				8 to 11	-	13 to 16	4 to 7
		Configured as outputs	2 to 5	9 to 12	-	0 to 3	
			8 to 11	13 to 16	-	4 to 7	
First Optional Module	3	2	Non Configurable	2 to 5	17 to 20	-	0 to 3
				8 to 11	21 to 24	-	4 to 7
	4	5	Configured as inputs	2 to 5	-	25 to 28	0 to 3
				8 to 11	-	29 to 32	4 to 7
		Configured as outputs	2 to 5	25 to 28	-	0 to 3	
			8 to 11	29 to 32	-	4 to 7	
Second Optional Module	5	3	Non Configurable	2 to 5	33 to 36	-	0 to 3
				8 to 11	37 to 40	-	4 to 7
	6	6	Configured as inputs	2 to 5	-	41 to 44	0 to 3
				8 to 11	-	45 to 48	4 to 7
		Configured as outputs	2 to 5	41 to 44	-	0 to 3	
			8 to 11	45 to 48	-	4 to 7	

Table 3-2 Decimal addresses of 'input / output' parameters in Modbus® protocol

The bits within a byte are numbered from **right to left** (LSB=0, MSB=7)



## PROFIBUS-DP PROTOCOL

Specifications for the **PROFIBUS-DP** (**P**rocess **F**ield **B**us **D**ecentralized **P**eriphery) protocol are defined in the following standards:

EN 50170 / DIN 19245 / Part 3.

**Important:** A detailed description of Profibus-DP operation is given in the 'REMIO: Profibus Communication Manual', ref. HA176078 ENG.

Transmission frames use binary characters with even parity  
Character format: 1 start bit - 8 data bits - 1 parity bit - 1 stop bit.

### Transmission rate

The rate used is adapted automatically. The available transmission rates are as follows:

9.6 kbaud  
19.2 kbaud  
93.75 kbaud  
187.5 kbaud  
500 kbaud  
1500 kbaud.

### State of ports

The state of the ports is stored in control word **CW**.  
The control word is present in two bytes of the diagnostic field, bytes **07 and 08**.

The **configuration type** (configurable ports only) is determined by the position of mini-switch **SW1.1**. This type (input or output) can be **read** in bit **11** of the **CW**.

- Bit **11** of **CW** = **0**: the configurable ports are configured as **inputs**
- Bit **11** of **CW** = **1**: the configurable ports are configured as **outputs**.

The type of **input logic** can be **read** and **written** in bit **0** of the **CW**:

- Bit **0** of **CW** = **0** : the inputs use **direct logic** :  
the input is active (bit = 1) if a contact is **closed**.
- Bit **0** of **CW** = **1** : the inputs use **inverted logic** :  
the input is active (bit = 1) if a contact is **open**.

The port state is **common** to all the REMIO's configurable ports.

It is possible to write to several REMIO units using the broadcast function.

The control word must be modified **before** any other operations are performed.

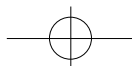

## Addressing

The **physical** address (address of the REMIO interface on the bus used) is set using the Profibus **Set\_Slave\_Address** function from the link Master, provided the REMIO unit is the only device on the bus and is in the wait for parameters phase (**WPRM**).

### Important!



As shipped from the factory, the REMIO interface's **default** physical address is set to: **32 (decimal)**

This address may be **reconfigured** by the user **using the digital link**.  
Ensure that there is only **one unit** at each physical address.

In normal operation the following addresses may be used: **4 to 125**

Addresses **0 to 3** are generally reserved for the Master.

Address **126** is not accepted by the REMIO.

Address **127** is reserved for broadcasting in accordance with the Profibus standard

The **output** addresses are accessible for **read/write** access.

Outputs may be modified by **broadcast**.

**Input** addresses are accessible for **read** access only.

Each REMIO **port** is represented by one **byte**.

Each **input** or **output** is defined by **one** of the **8 bits** in the byte corresponding to the port.

MSB							LSB
7	6	5	4	3	2	1	0

Table 3-3 Organisation of bits in port byte

The input / output logic parameters can be set to **0** or **1**.

The input / output parameters are accessible at the addresses present in the table below.

## Input / output addresses

The table below gives:

- the output addresses (configurable ports configured as outputs)
- the input and output addresses (configurable ports configured as inputs)

Port parameter				'Input / output' logic parameter				
Module	Port	Port address	Port configuration	Terminal	Output No.	Input number	Bit No. in port byte	
Base module	1	0	Non Configurable	2 to 5	1 to 4	-	0 to 3	
				8 to 11	5 to 8	-	4 to 7	
	2	3	Configured as inputs	2 to 5	-	9 to 12	0 to 3	
				8 to 11	-	13 to 16	4 to 7	
				Configured as outputs	2 to 5	9 to 12	-	0 to 3
					8 to 11	13 to 16	-	4 to 7
First Optional Module	3	1	Non Configurable	2 to 5	17 to 20	-	0 to 3	
				8 to 11	21 to 24	-	4 to 7	
	4	4	Configured as inputs	2 to 5	-	25 to 28	0 to 3	
				8 to 11	-	29 to 32	4 to 7	
			Configured as outputs	2 to 5	25 to 28	-	0 to 3	
				8 to 11	29 to 32	-	4 to 7	
Second Optional Module	5	2	Non Configurable	2 to 5	33 to 36	-	0 to 3	
				8 to 11	37 to 40	-	4 to 7	
	6	5	Configured as inputs	2 to 5	-	41 to 44	0 to 3	
				8 to 11	-	45 to 48	4 to 7	
			Configured as outputs	2 to 5	41 to 44	-	0 to 3	
				8 to 11	45 to 48	-	4 to 7	

Decimal addresses of 'input / output' parameters in Profibus-DP protocol

## State diagram

The state diagram for data transfers using a read / write process comprises **four states** (see figure 3-2):

- powering up
- waiting for parameters
- waiting for configuration
- transfer of parameter data

### Powering up

After powering up, the unit enters a **wait phase** with two sequences:

- parameter setting
- configuration.

### Parameter settings

This is the **wait for parameter message** phase (**WPRM**).

In this phase, the configuration may be read (**Get\_Cfg**).

A diagnostic request (**Slave\_Diag**) is allowed.

The parameter setting frame (**Set\_Prm**) contains the following information:

- system parameter settings (**PNO** identification, acceptance of synchronisation modes, watchdog time, etc.).
- data parameter settings (parameters designated by the master to be accessible for cyclic reading).

Also, as described in the 'Addressing' section above, during the **WPRM** phase the REMIO interface address may be changed using the **Set\_Slave\_Address** function.

Any other type of message will be rejected during the wait for parameters phase.

### Important!



REMIO parameter settings are fixed and unique for all devices.

### Configuration

This is the **wait for configuration message** phase (**WCFG**).

The configuration message specifies the structure of the input and output buffers.

Parameter setting (**Set-Prm**) and diagnostic requests (**Slave\_Diag**) are permitted.

Any other type of message will be rejected during the wait for configuration phase.

In a given installation, the REMIO interface can only receive a configuration change message (**Check\_Cfg**) from the master which set its parameters.

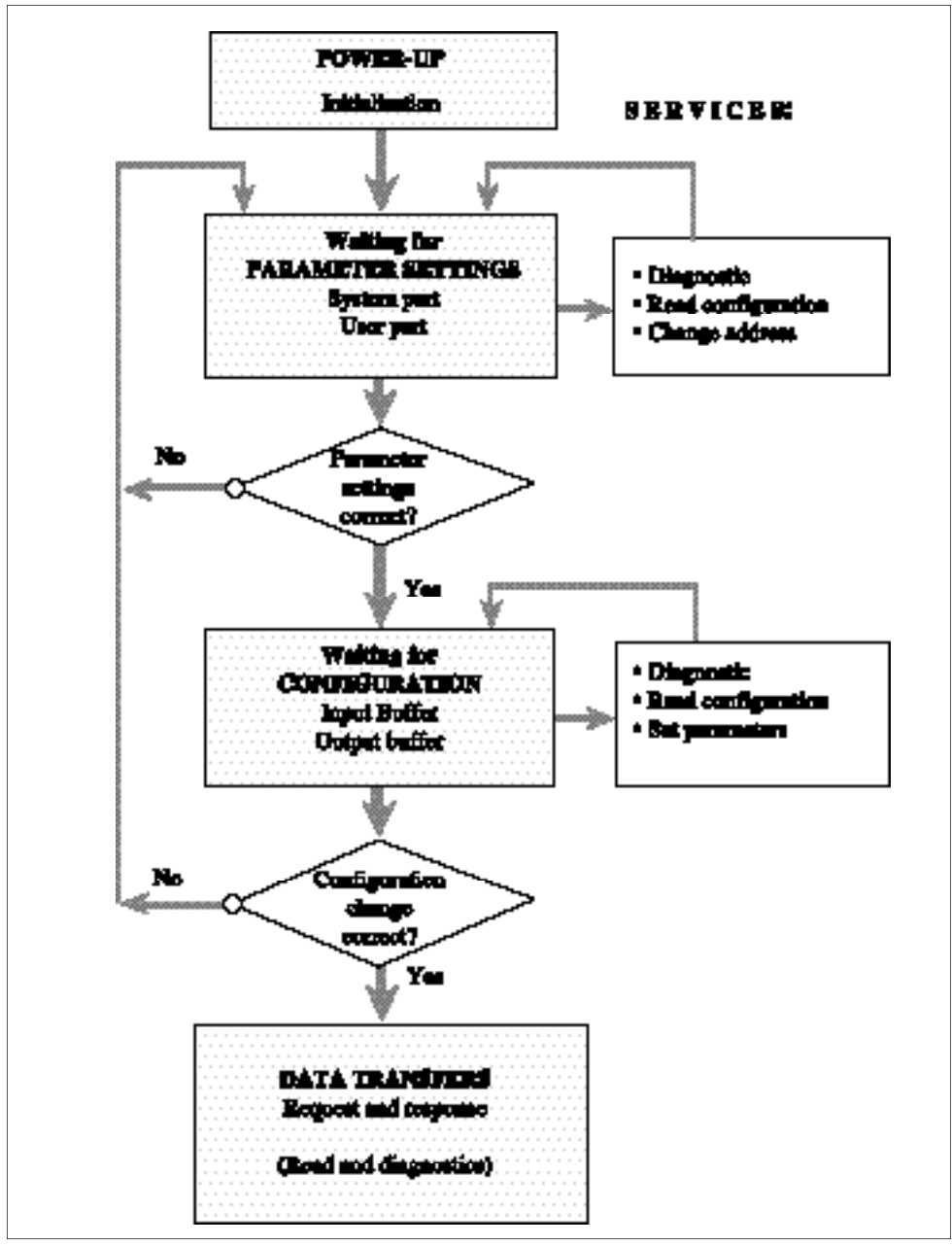

Figure 3-2 State diagram for read/write procedure using Profibus-DP protocol



## Data transfer

Once the parameter settings and configuration have been accepted, in the data exchange phase (**DXCHG**), the REMIO interface is ready to send data to the master which set its parameters and configured it.

The following types of data may be transferred during the **DXCHG** phase:

- Diagnostic (**Slave\_Diag**)
- Parameter settings and Configuration:
  - Read configuration (**Get\_Cfg**)
  - Check configuration (**Check\_Cfg**)
  - Set parameters (**Set\_Prm**)
- Process data transfer:
  - Request and response (**Data\_Exchange**)
  - Multiple data read (**Read\_Input**); rarely used
  - Read back outputs (**Read\_Output**); rarely used.
- Control of transmission modes (**Global\_Control**).

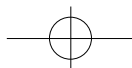
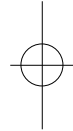
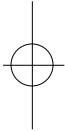

## DEVICENET PROTOCOL

**DeviceNet** is a **serial** communications protocol designed for communication between simple industrial units and their supervision or control units.

**Important:** A detailed description of DeviceNet operation is given in the 'REMIO: DeviceNet Communication Manual', ref. HA176272 ENG.

All REMIO communications and operations variables are considered as **DeviceNet objects**.

Under the **DeviceNet 2.0** specification, REMIO is in the category '**Group 2 Only Predefined Master / Slave Device**'.

REMIO inputs / outputs take the form of an object named '**REMIO Variable**'.  
«**Variable REMIO**».

It is possible to transfer all 'REMIO variables' with a '**Poll I / O Connection**'.

Under the rules imposed by the specification, all DeviceNet objects and their attributes are accessible with an '**Explicit Messaging Connection**'.

'REMIO Variables' corresponding to REMIO interface inputs / outputs are members of the type '**DeviceNet USINT**' handled by the '**GET\_Attribute\_Single**' and '**SET\_Attribute\_Single**' DeviceNet access services.

These 'REMIO Variables' are identified by their Identifiers (addresses).

### Transmission rate

The transmission rate for the DeviceNet protocol:

**125, 250 or 500** kbaud  
can be **configured** using mini-switches **SW1.2** and **SW1.3**.

## State of ports

The state of the ports (configurable ports only) is stored in the **control word**.  
The control word (CW) is present in two bytes (identifier = 100).

The configuration (inputs or outputs depending on the position of mini-switch **SW1.1** can be **read** in bit **11** of the **CW**.

- Bit **11** of **CW** = **0**: the configurable ports are configured as **inputs**
- Bit **11** of **CW** = **1**: the configurable ports are configured as **outputs**.

The type of **input logic** can be **read** and **written** in bit **0** of the **CW**:

- Bit **0** of **CW** = **0** : the inputs use **direct logic** :  
the input is active (bit = 1) if a contact is **closed**.
- Bit **0** of **CW** = **1** : the inputs use **inverted logic** :  
the input is active (bit = 1) if a contact is **open**.

The port state is **common** to all the REMIO's configurable ports.  
It is possible to write to several REMIO units using the broadcast function.

The control word must be modified **before** any other operations are performed.

## Error codes

As soon as the slave detects an error in the request from the master, an error code is used in the response code. The 'General Error Service' code is **14<sub>HEX</sub>**.

Error code (hexadecimal)	Error type
2	Resource not available
8	Service not supported
9	Data value out of range
0B	Already in requested state
0C	Object state conflict
0E	Attribute not modifiable
0F	Access refused
10	State conflict
11	Data too large
13	Insufficient data
14	Attribute not supported (not authorised)
15	Too much data
16	Object does not exist
18	No stored attribute data
19	Storage failure
1F	Vendor-specific error
20	Invalid parameter

Table 3-4 Meaning of DeviceNet error codes

## Addressing (Identification)

The REMIO interface's **identifier (physical address) 'MACID'** is set at configuration time via the communications bus, using the **'Explicit Messaging Connection'** of the **Device\_Net** object.



### Important!

As shipped from the factory, the REMIO interface's **default** physical address is set to: **32 (decimal)**

This address may be **reconfigured** by the user **using the digital link**.

Ensure that there is only **one unit** at each physical address.

Each REMIO **port** has a **one byte identifier** (port address). In normal operation identifiers from **0** to **63** may be used.

Each **input** or **output** is defined by **one** of the **8 bits** in the byte corresponding to the port. The input / output logic parameters can be set to **0** or **1**.

Port parameter				'Input / output'logic parameter			
Module	Port	Port address	Port configuration	Terminal	Output No.	Input number	Bit No. in port byte
Base module	1	1	Non Configurable	2 to 5 8 to 11	1 to 4 5 to 8	- -	0 to 3 4 to 7
			Configured as inputs	2 to 5 8 to 11	- -	9 to 12 13 to 16	0 to 3 4 to 7
	Configured as outputs	2 to 5 8 to 11	9 to 12 13 to 16	- -	0 to 3 4 to 7		
First Optional Module	3	2	Non Configurable	2 to 5 8 to 11	17 to 20 21 to 24	- -	0 to 3 4 to 7
			Configured as inputs	2 to 5 8 to 11	- -	25 to 28 29 to 32	0 to 3 4 to 7
	Configured as outputs	2 to 5 8 to 11	25 to 28 29 to 32	- -	0 to 3 4 to 7		
Second Optional Module	5	3	Non Configurable	2 to 5 8 to 11	33 to 36 37 to 40	- -	0 to 3 4 to 7
			Configured as inputs	2 to 5 8 to 11	- -	41 to 44 45 to 48	0 to 3 4 to 7
	Configured as outputs	2 to 5 8 to 11	41 to 44 45 to 48	- -	0 to 3 4 to 7		

Table 3-5 Identification of REMIO 'Input/Output' variables in DeviceNet protocol.

Bits within a byte are numbered from **right to left** (LSB = 0; MSB = 7).

## Operating state diagram

The state diagram for the REMIO interface comprises **four states** (see figure 3-3):

- powering up
- waiting for parameters
- waiting for configuration
- transfer of REMIO DeviceNet variable

### Powering up

Each time the unit is powered up it enters an **initialisation phase**.

### Self test

After initialisation, if all the **internal resources** and the **stored configuration** are **valid**, the REMIO interface enters a state which allows communications to take place.

If not, the REMIO interface enters one of the following states:

- **waiting for configuration** (if necessary)
- **shutdown** in the event of a non-recoverable error.

### Configuration

The configuration necessary to operate the REMIO interface with the DeviceNet protocol is described in the manual 'REMIO: DeviceNet Communication Manual', ref. H A176272 ENG.

### Operation

This is the normal state of the REMIO interface, in which it is ready to exchange data with the link master.

### Shutdown

If a **non-recoverable** error occurs, the REMIO interface enters a shutdown state. To resume normal operation after the **fault is corrected**:

- switch the unit **off** then
- switch it **on** again.

**Non-recoverable** faults include:

- unit configured to an address **already assigned** to another device on the same bus.
- internal operating problem.

Communications

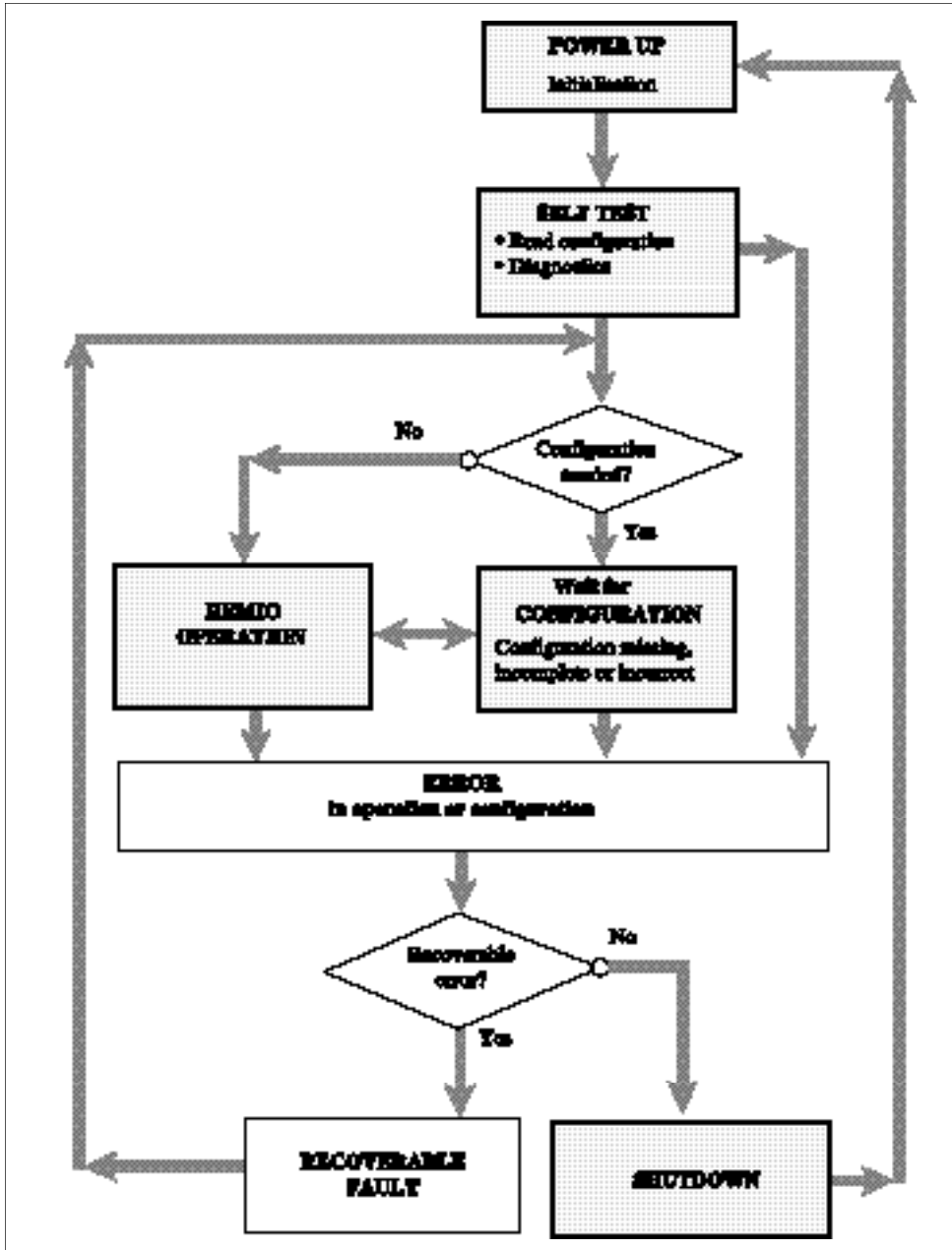

Figure 3-3 State diagram for REMIO operation with DeviceNet protocol

## Chapter 4

# CONFIGURATION

	Page
General . . . . .	4-2
Configurable ports . . . . .	4-4
Transmission rate . . . . .	4-4
Termination resistors . . . . .	4-5
Modbus and Profibus protocols . . . . .	4-5
DeviceNet protocol . . . . .	4-6

## Chapter 4 CONFIGURATION

### GENERAL

The REMIO interface is configured using mini-switches **SW1** located on the top of the unit.

Viewed from above, with the front panel facing the user, the **ON** position is to the **left** (see figure 4-1).

Mini-switches **SW1** determine:

- use of configurable ports
- transmission rate
- communications bus termination resistors.

Mini-switch	Function depending on protocol		
	Modbus	Profibus	DeviceNet
SW1.1	Configuration of configurable ports	Configuration of configurable ports	Configuration of configurable ports
SW1.2	Transmission rate	Not used	Transmission rate
SW1.3	Bus termination / polarisation	Bus termination / polarisation	Transmission rate
SW1.4	Bus termination / polarisation	Bus termination / polarisation	Not used

Table 4-1 Function of configuration mini-switches

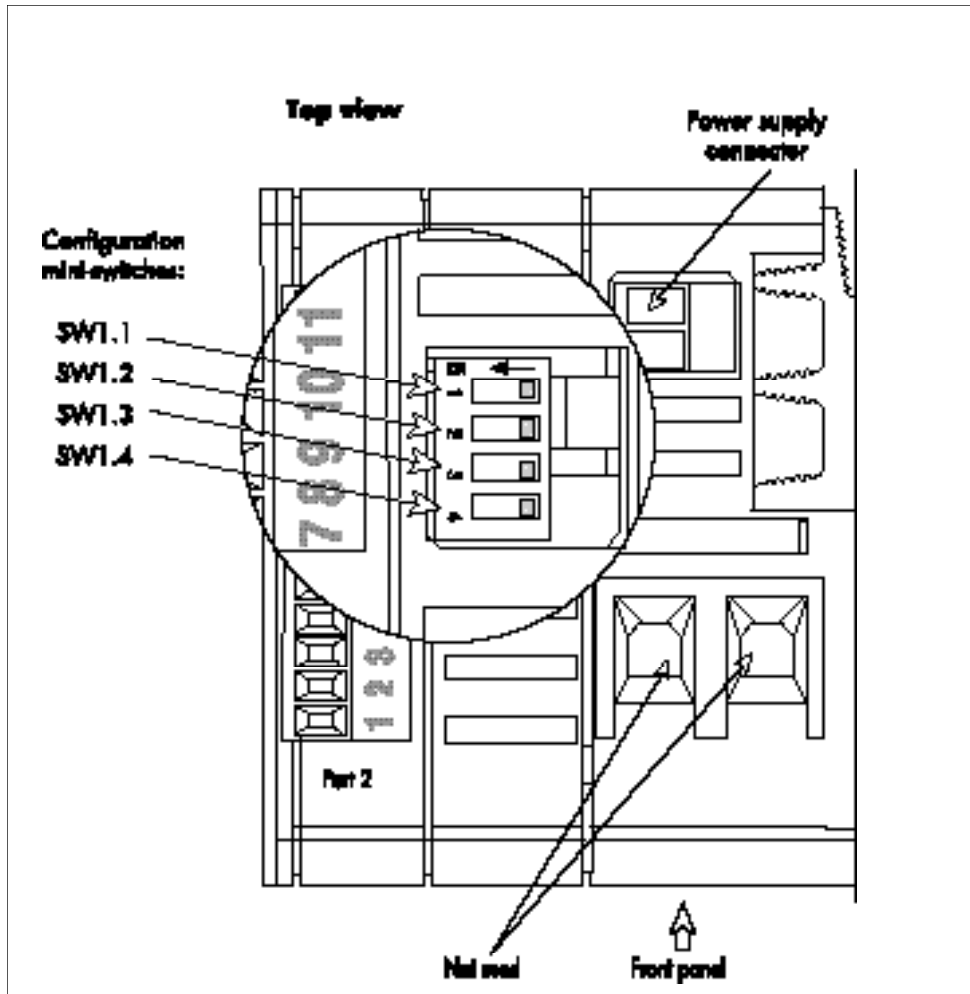

Figure 4-1 Layout of configuration mini-switches

SW1 mini-switch positions

- ON** = mini-switch to **left** (direction of arrow)
- OFF** = mini-switch to **right**  
(view from above, front panel facing user).

## CONFIGURABLE PORTS

The function of the configurable ports (digital outputs or inputs) is selected **simultaneously** using mini-switch **SW1.1** for port **2** on the base module and for ports **4** and **6** on the optional modules.

Function of Configurable ports	Position of mini-switch SW1.1
Digital outputs	ON
Digital inputs	OFF

Table 4-2 Port configuration



**Important!** When the units leave the factory, SW1.1 is set to **ON** by default (ports configured as digital outputs).

## TRANSMISSION RATE

The transmission rate is configured by:

- mini-switch **SW1.2** for the **Modbus** protocol
- mini-switches **SW1.2** and **SW1.3** for the **DeviceNet** protocol.

For the **Profibus** protocol the transmission rate is defined by the link master. The REMIO interface automatically adjusts to the corresponding rate; no configuration is necessary.

Protocol	Transmission rate (kbaud)	Position of mini-switches	
		SW1.2	SW1.3
Modbus	9.6	OFF	Used for bus termination resistor configuration
	19.2	ON	
DeviceNet	125	OFF	OFF
	250	ON	OFF
	500	OFF	ON
Profibus	Up to 1500	Not used: auto baud rate selection	Used for bus termination resistor configuration

Tableau 4-3 Configuration de la vitesse de transmission

## TERMINATION RESISTORS

### Modbus and Profibus protocols

The communications bus must be fitted with termination resistors at each end:

- one line impedance **matching resistor**
- two RS485 bus **polarisation resistors**.

Mini-switches **SW1.3** and **SW1.4**, located on the top of the REMIO interface, are used to connect internal resistors to the end of the communication bus.

#### Important!



Only the **last device** on the communications bus should be fitted with an impedance matching resistor.

If the REMIO is the last device on the bus, mini-switches **SW1.3** and **SW1.4** must be set to **ON**.

For all other REMIO interfaces on the same communications bus, mini-switches **SW1.3** and **SW1.4** must be set to **OFF**.

Switches **SW1.3** and **SW1.4** must always be **both in the same position**.

When shipped from the factory, mini-switches **SW1.3** and **SW1.4** are set to **OFF**.

The value of the matching resistor varies depending on the characteristic impedance of the line (120 Ω to 220 Ω). The REMIO internal matching resistor is **220 Ohms**.

The polarisation resistors are **390 Ohms** connected to each power rail.

The **resulting** impedance (with SW1.3 and SW1.4 set to ON) is **170 Ohms**.

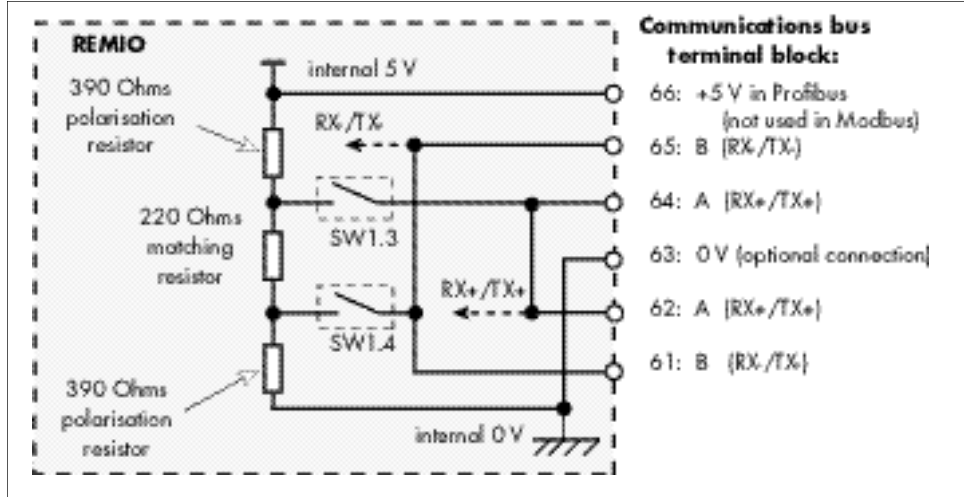

Figure 4-2 Termination resistor configuration (Modbus and Profibus)



Configuration

---

## DeviceNet protocol

The communications bus must be fitted with a line impedance **matching resistor** at each end (**external** to the REMIO interface).

The **CAN** bus used by the DeviceNet protocol does not need polarisation resistors, as the operation of the bus is defined by impedance.

### Important!



Only the **last device** on the communications bus should be fitted with an impedance matching resistor.

The position of mini-switch **SW1.4** is not important.

The value of the external matching resistor depends on the characteristic impedance of the CAN bus. For the DeviceNet protocol a **120 Ohms** matching resistor is used.

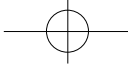
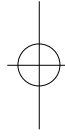
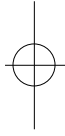

# Chapter 5

## OPERATION

	Page
Thyristor firing. . . . .	5-2
Port operation. . . . .	5-2
Non configurable ports . . . . .	5-2
Configurable ports . . . . .	5-2
Common potential . . . . .	5-3
Direct and inverted input logic . . . . .	5-3
Operation of LEDs. . . . .	5-4
Layout of LEDs . . . . .	5-4
Base module. . . . .	5-4
Optional module . . . . .	5-4
Power supply LED. . . . .	5-4
Input configuration LEDs. . . . .	5-4
Diagnostic LEDs . . . . .	5-5
Modbus and Profibus protocols . . . . .	5-5
DeviceNet protocol . . . . .	5-5

Operation

## Chapter 5 OPERATION

### THYRISTOR FIRING MODES

The outputs of the REMIO/Logic communications interface drive the solid state relays in 'On-Off' firing mode.

Thyristor firing and cut-off occurs when the solid state relay supply crosses zero. This firing is performed by the electronics in the thyristor units.

### PORT OPERATION

#### Non configurable ports

The **Non configurable** ports (upper ports) always operate as outputs. This concerns port **1** (base module), port **3** (optional module 1) and port **5** (optional module 2).

The logic signal from a non configurable output is **20 Vdc** nominal.  
The maximum current is limited to **6.5 mA**.

**Two** of the following solid state relays may be connected **in series** to each digital output:  
TE10S/DC, TE10S/PLF, TE10S/PDS, TE200S, TE300/Logic input.

#### Configurable ports

The **Configurable** ports (lower ports) can operate as outputs or inputs depending on the position of mini-switch **SW1.1** (see Configuration). This concerns port **2** (base module), port **4** (optional module 1) and port **6** (optional module 2).

The port configuration can be read by digital communications using Control Word **CW**. The **configuration type** (determined by the position of mini-switch **SW1.1**) can be **read** in bit **11** of the **CW**.

- Bit **11** of **CW = 0**: the configurable ports are configured as **inputs**
- Bit **11** of **CW = 1**: the configurable ports are configured as **outputs**.

The port state is **common** to all the REMIO's configurable ports.

The logic signal from a configurable output is **20 Vdc** nominal.  
The maximum current is limited to **6.5 mA**.

The logic signal to the configurable inputs must use a 'dry' contact or equivalent (maximum current limited to **6.5 mA** by REMIO).

## Common voltage

A **common +20 Vdc** voltage is available for each input or output on each port.

## Direct and inverted input logic

The **input logic type** can be **read** and **written** using **bit 0** of the **CW**.

### Direct logic

The input is **active** when it is **disconnected from the common +20 Vdc** by an **open** contact.  
Bit **0** of control word **CW** is set to **1**.

### Inverted logic

The input is **active** when it is **connected to the common +20 Vdc** by a **closed** contact.  
Bit **0** of control word **CW** is set to **0**.

The example below shows connection of the partial load failure (PLF) alarm relay contact on a **TE10S** solid state relay.

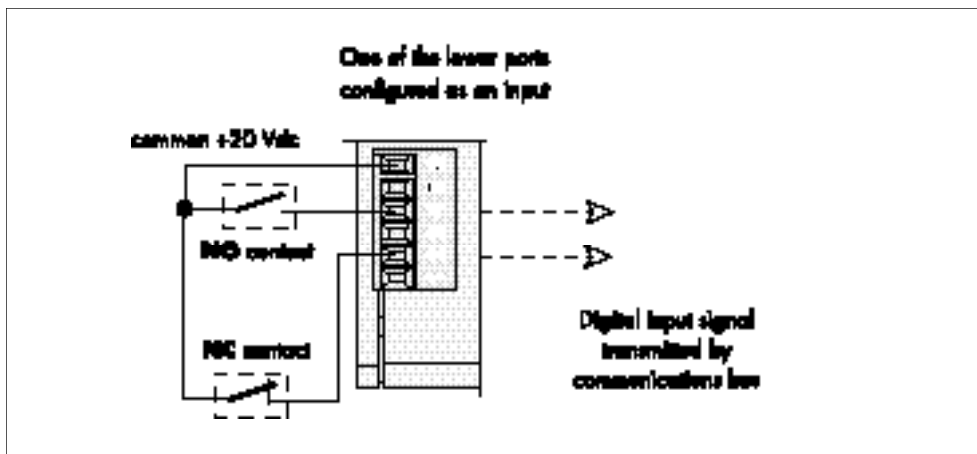

Figure 5-1 Signals transmitted by inputs

The user can choose a Normally Open (NO) or Normally Closed (NC) contact.

The input used (No. 2 or 4 on figure 5-1) will be active depending on the **state of the contact** and the **type of logic** configured.

## OPERATION OF LEDs

### Layout of LEDs

#### Base Module

The front panel of the Base Module contains one **orange** input configuration LED and two diagnostic LEDs. The function of the diagnostic LEDs varies according to the protocol.

##### Profibus and Modbus protocols:

- one **red** LED indicating the **state of communications**
- one **green** LED indicating the presence of the **power supply**

##### DeviceNet protocol:

- one **bi-colour** LED indicating the **state of the REMIO interface**
- one **bi-colour** LED indicating the **state of the bus**.

#### Optional modules

Each optional module has:

- one **green** LED indicating the presence of the **power supply**
- one **orange** LED indicating the **configuration** of the inputs.

### Power supply LED

The green power supply ‘**On**’ LED on each module is lit if the module (base module or optional module) is supplied with power.

The ‘‘**On**’ LED is not lit if the power supply to the module is **cut**.

### Input configuration LED

The orange ‘**Input**’ LED on each module indicates whether the **configurable** ports are operating as **inputs** or **outputs**.

The ‘**Input**’ LEDs on the base modules and the operational modules are **all lit** if the configurable ports are operating as **inputs**.

They are **all unlit** if the configurable ports are operating as **outputs**.

**Reminder:** The configuration is set with mini-switch **SW1.1** for **all** configurable ports **simultaneously**.

## Diagnostic LEDs

### Modbus and Profibus protocols

Two LEDs are used to diagnose the state of the communications bus

- one **green** LED marked '**Data Exchg**'
- one **red** LED marked '**No comms**'.

LED operation		Diagnostic
'Data Exchg'	'No comms'	
Lit	Unlit	Normal data transfer. The communications bus is active and the time set by the 'Time_Out' parameter has not elapsed since the last valid communications frame.
Unlit	Unlit	Unlit Lit Communications cut. Bus not active or time-out elapsed.
Unlit	Unlit	No power supply The REMIO interface is not communicating.

Table 5-1 Diagnostic LEDs for Modbus and Profibus protocols

### DeviceNet protocol

Two **bi-colour** LEDs are used for diagnostics:

- the **green/red** '**Module Status**' LED indicates the state of the REMIO interface.
- the **green/red** '**Network Status**' LED indicates the state of the communications bus.

The two LEDs operate independently

Bi-colour LED operation	Diagnostic	
	'Module Status' REMIO diagnostics	'Network Status' Communications diagnostics
Unlit	REMIO not powered	REMIO not powered
Green - Red - Green	Start-up auto-test	Start-up auto-test
Flashing green	REMIO waiting: configuration missing, incomplete or incorrect	Communication OK, REMIO not assigned to a master
Steady green	REMIO operational	Communication OK, REMIO assigned to a master
Flashing red	Auto-recoverable fault	Time-out elapsed
Steady red	REMIO out of service.	Communications problem

Table 5-2 Diagnostic LEDs for DeviceNet protocol

---

**EUROTHERM LIMITED**

**<http://www.eurotherm.co.uk>**

UK SALES OFFICE

Eurotherm Limited

Faraday Close, Durrington

Worthing

West Sussex BN13 3PL

Telephone Sales: (01903) 695888

Technical: (01903) 695777

Fax: (01903) 695666

**Sales and support in over 30 countries worldwide**

For countries not listed overleaf, enquiries/orders to:

**Eurotherm Limited**

Export Dept.,

Faraday Close, Durrington, Worthing

West Sussex, BN13 3PL

Telephone (01903) 268500

Fax (01903) 265982