

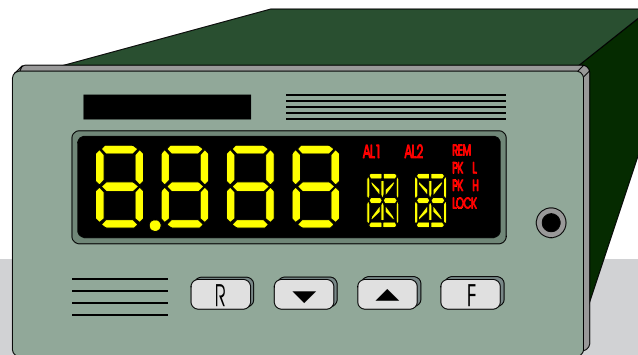

DPS

DIGITAL PANEL INDICATOR



INSTRUCTION MANUAL

DIMENSIONS AND PANEL CUT-OUT

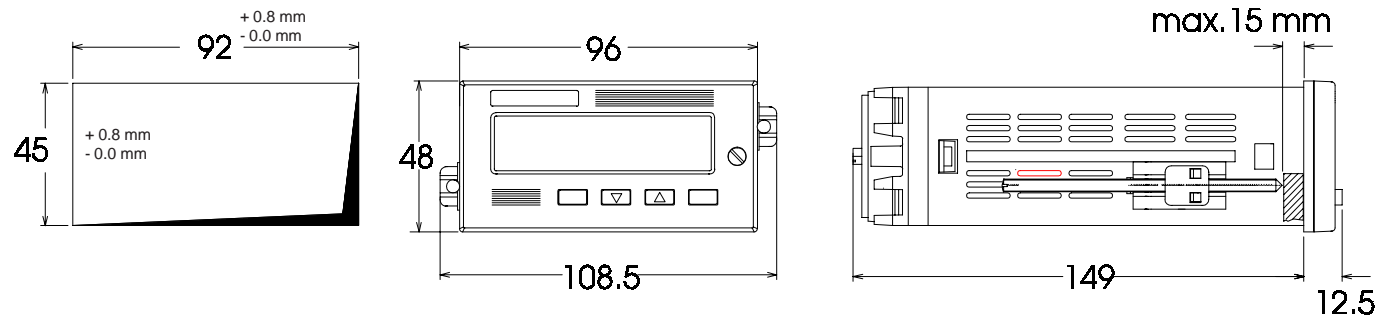

HORIZONTAL MOUNTING : Min distance between cut outs : 20 mm

PACKING OF MORE INSTRUMENT IN A SINGLE CUT OUT (max 10 instruments): The total dimension of the cut out is the addition of the front dimensions minus 3 mm. Vertical dimension of the cut out = $(n \times 48) - 3$ mm where n is the number of instruments to be packed.

CONTENTS

SECTION 1 GENERAL INFORMATION

1.1	INTRODUCTION	Page	5
1.2	PRODUCT SPECIFICATIONS		5
1.3	OPTIONS		8
1.4	CODING		9
1.5	LABELS		10

SECTION 2 INSTALLATION

2.1	MOUNTING		12
2.2	WIRING GUIDE LINES		13

SECTION 3 INSTRUMENT CONFIGURATION

3.1	FRONT PANEL DESCRIPTION		24
3.2	INSTRUMENT CONFIGURATION		27

SECTION 4 OPERATING INSTRUCTIONS

4.1	PRELIMINARY		40
4.2	OPERATIVE MODE		40

SECTION 5 INSTRUMENT CALIBRATION PROCEDURE

5.1	DIP SWITCHES LOCATION		43
5.2	GENERAL GUIDE LINES FOR CALIBRATION		44
5.3	CALIBRATION PROCEDURE		44

SECTION 6 DEFAULT PARAMETERS SETTING

6.1	PRELIMINARY		54
6.2	DEFAULT PARAMETERS SETTING		54
6.3	DEFAULT CONFIGURATION PARAMETERS		54
6.4	DEFAULT CALIBRATION PARAMETERS		55
6.5	DEFAULT OPERATIVE PARAMETERS		55

SECTION 7 ERROR MESSAGES

7.1	OUT OF RANGE		56
7.2	OPEN INPUT CIRCUIT		56
7.3	ERRORS		56
7.4	ERROR DESCRIPTIONS		57

APPENDIX A			62
-------------------	--	--	----

SECTION 1 GENERAL INFORMATION

1.1 INTRODUCTION

The DPS is a family of digital panel indicators developed with a variety of features for the solution of field problems. As part of ERO ELECTRONIC background, this family also maintains a high standard in quality, reliability and man/machine interface simplicity, but it encompasses performance typically built in very expensive instruments.

Features like frequency input, switching power supply, square root extraction on the input variable, linearization by keyboard with the setting of 9 breakpoints (10 segments), max. value data hold, min. value data hold and analog retransmission of the displayed value offer the widest range of possible application.

The two color custom integrated display with 4 numerical digit, 2 alphanumerical characters and 6 indicators, is an example of the particular attention given to the design of the man/machine interface.

The DPS comes with a complete availability of ranges from thermocouple, RTD and mA, digital filter, two logic inputs, two independent alarms and it can be also supplied with serial communication interface and a galvanically isolated auxiliary power supply.

1.2 PRODUCT SPECIFICATIONS

1.2.1 GENERAL SPECIFICATIONS

Case : PC/ABS black color; self-extinguishing degree : V-0 according to UL.

Front panel : IP 54 protection (IEC 529 and CEI 70-1).

Installation : panel mounting by means of tie rods.

Instrument removable from case by screwdriver help

Plug in construction : PC boards are assembled by snap in action for easy inspection and replacement of all boards.

Rear terminal block: with screw terminals and completed with identification labels, connection diagrams and safety rear cover.

Dimensions: DIN 43700 48 x 96 mm, depth 149 mm.

Cut-out : 45 x 92 mm +0,8 mm - 0,0 mm.

Weight : 600 g max.

Displays: LCD with high brightness solid state back lighter
numerical display: 4 digits, 7 segments with decimal point,
14.5 mm high, from -1999 to 9999.

alphanumerical display: 2 digits, 16 segments with
decimal point, 9 mm high,

Front indicators: AL1- AL2- PK H- PK L- LOCK- REM.

Power supply: 100V to 240V AC 50/60Hz (-15% to +10% of the nominal value). or 24 V AC/D.C (±10% of the nominal value).

Power consumption : 8 VA max.

Insulation resistance: > 100 MΩ according to IEC 348.

Dielectric strength: 1500 V in accordance with IEC 348.

Conversion: dual slope integration.
Resolution: 25000 counts
Sampling time: 100 ms typical.
Display updating time: 400 ms typical.
Accuracy: $\pm 0.1\%$ fsv ± 1 digit @ 25 °C ambient temperature.
Common mode rejection ratio: 120 dB @ 50/60 Hz.
Normal mode rejection ratio: 60 dB @ 50/60 Hz.
Noise immunity: according to IEC 801-4, level 3
Temperature drift: < 200 ppm/°C on fsv (CJ excluded)
Ambient temperature: 0 to 50 °C.
Storage temperature : -20 to +70 °C
Humidity: 20 to 85% RH, non condensing.
Protections: 1) WATCH DOG circuit for automatic restart.
 2) DIP SWITCHES for protection against tampering of configuration and calibration parameters.

1.2.2 INPUTS

Inputs: 4 type of inputs are available:

A) Thermocouple: B - E - J - Fe/Cu Ni - K - N - R - S - T - Cu/Cu Ni - W - W3 - W5 - PLATINEL - Ni/Ni 18%Mo.
 Type of TC and °C/°F programmable.

External resistance: 100 Ω max, with maximum error 0.1% of span.

Cold junction: automatic compensation 0 to 50 °C.

Burn out: up scale or down scale programmable.

Input impedance: > 1 M Ω

Standard ranges: see table, others on request.

Calibration : according to IEC 584-1 (if not specified)

STANDARD RANGES TABLE

TC type	Ranges		NOTE
B	+32 / +3300 °F	0 / +1820 °C	(1)
E	-328 / +1470 °F	-199.9 /+800.0 °C	
J	-328 / +1830 °F	-199.9 /+999.9 °C	
Fe-CuNi	-328 / +1650 °F	-199.9 /+900.0 °C	DIN 43710-1977
K	-328 / +2500 °F	-199.9 / +1370 °C	(2)
R	-58 / +3200 °F	-50 / +1760 °C	
S	-58 / +3200 °F	-50 / +1760 °C	
T	-328 / +750 °F	-199.9 /+400.0 °C	
Cu-CuNi	-328 / +1110 °F	-199.9 /+600.0 °C	DIN 43710-1977
N	+32 / +2550 °F	0 / +1400 °C	
W	+32 / +4190 °F	0 / +2310 °C	
W3	+32 / +4190 °F	0 / +2310 °C	ASTM - E988/84
W5	+32 / +4190 °F	0 / +2310 °C	ASTM - E988/84
Ni/Ni-Mo	+32 / +2192 °F	0 / +1200 °C	GE Co.
Platinel II	+14 / +2550 °F	-10 / +1400 °C	GHOST

1) Accuracy and resolution guaranteed from 300 °C (570 °F)

2) Resolution $1/10$ °C up to 999.9 °C

B) Linear input**Input type:** See table below**Readout:** keyboard programmable between -1999 and +9999.**Linearization:** input signal may be linearized by setting up to 9 breakpoints (10 segments) on the input span.**Square root extraction:** programmable**Decimal point :** programmable in any position.**Burn out:** Up scale for 12-60 mV inputs;
down scale for 4-20 mA, 1-5 V and 2-10 V.
It is not detectable for the other ranges.

STANDARD RANGES TABLE

Input type	Input impedance	Accuracy
0 - 20 mA	3 Ω	0.1 % \pm 1 digit @ 25°C
4 - 20 mA	3 Ω	
0 - 60 mV	\geq 800 k Ω	
12 - 60 mV	\geq 800 k Ω	
0 - 5 V	\geq 200 k Ω	
1 - 5 V	\geq 200 k Ω	
0 - 10 V	\geq 200 k Ω	
2 - 10 V	\geq 200 k Ω	

C) RTD (Resistance Temperature Detector)**Input:** for RTD Pt100 Ω and Ni 100 Ω , 3 wire connection with °C/°F selectable by front pushbuttons.**Input circuit:** current injection (100 μ A).**Line resistance:** automatic compensation up to 3 Ω /wire with no measurable error.**Calibration:** according to DIN 43760**Standard ranges:** see table**Burn out:** up scale or down scale programmable for open circuit of one or more wires.

STANDARD RANGES TABLE

Input type	Ranges	
RTD Pt 100 Ω	- 328 / + 1560 °F	- 199.9 / + 850.0 °C
RTD Ni 100 Ω	- 76 / + 660 °F	- 60.0 / + 350.0 °C

1.2.3 ALARMS

Number of alarms: two independent

Threshold: from 0 to 100 % of the readout span.

Hysteresis: programmable from 0.1 to 5.0 % of the readout span.

Type of alarm: High or low alarms programmable.

NOTE : The alarm becomes active at the alarm threshold value and will be reset at the alarm threshold value plus or minus the hysteresis value, according to the alarm type.

Reset: Automatic or Manual, programmable.

The manual reset of the alarms is possible by front pushbuttons individually or by external contact collectively.

Alarm outputs: two relays, SPST, NC or NO selectable by jumpers.

Contact rating: 2A - 30 V DC or 0.6 A - 110 V DC or 0.5 A - 250 V AC, on resistive load or 0.3 A - 110 V DC on inductive load.

Relay status: relay energized in no alarm condition.

Digital filter: it is possible to set, on the alarm function, a digital filter with the same time constant chosen for the readout.

Alarms indication: AL1 and AL2 indicators lit for alarm ON status.

1.2.4 ADDITIONAL FUNCTIONS

Peaks detection : visualization of the max. and min. value measured by the instrument

Digital filter: it is possible to set a digital filter on the displayed value with a time constant of 0.4, 1, 2, 3, 4 or 5 s. This filter can be set for analog retransmission and alarms threshold also.

Logic input: one input by contact for manual reset of the alarms or HOLD function enable.

Safety lock: for protection of the alarms threshold values.

1.3 OPTIONS

1.3.1 COMMUNICATION INTERFACE

Type: RS-485 optoisolated.

Communication type: bi-directional.

Protocol: "Polling/Selecting"

Baud rate: from 150 baud to 19200 baud.

Format: 7 bits + parity bit

8 bits + parity bit

8 bits without parity bit

Parity: odd or even

Stop bit: one

1.3.2 ANALOG RETRANSMISSION

Isolated analog retransmission of the displayed value.

Scaling: programmable between -1999 and 9999

Output type: 1) 0-20 mA or 4-20 mA, max. load 500 Ω , optoisolated
2) 0-10 V, minimum load 5000 Ω , optoisolated

Selection: between 0-20 mA, 4-20 mA and 0-10 V by internal jumper and frontal keyboard.

Resolution : max. 0.1 % of the output span.

Accuracy: 0.2 % of the output span (@ 25°C).

Temperature drift: < 100 ppm/°C.

Digital filter: it is possible to set a digital filter on the retransmitted value with a time constant equal to the time constant selected for the readout value.

NOTE: The analog retransmission excludes the serial interface option.

1.3.3 AUXILIARY POWER SUPPLY

Isolation: galvanically isolated from instrument input and output.

Voltage output: 5, 10, 12 or 24 V DC selectable by jumpers.

Accuracy : $\pm 5\%$

Max. power: 0.5 W

1.4 CODING

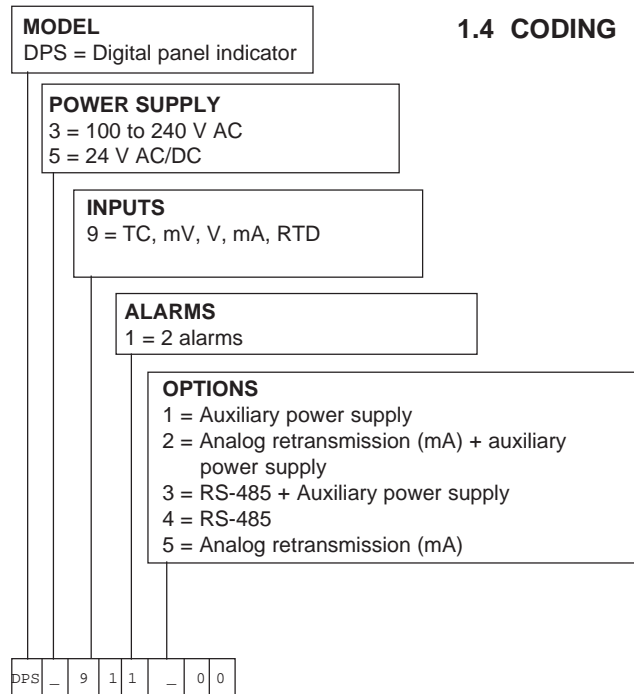



SECTION 2 INSTALLATION

2.1 MOUNTING

Select a mounting location where there is minimum vibration and the ambient temperature must be between 0 and 50 °C.

The instrument can be mounted on a panel up to 15 mm thick with a cut out of 45 x 92 mm $\begin{matrix} +0.8 \text{ mm} \\ -0 \text{ mm} \end{matrix}$. Remove the two mounting brackets from both sides of the instrument, and insert the instrument through the panel cut-out.

While holding the instrument against the panel, insert the mounting brackets and lock them by using a screwdriver until the instrument is held against the panel (see Fig. 2.1).

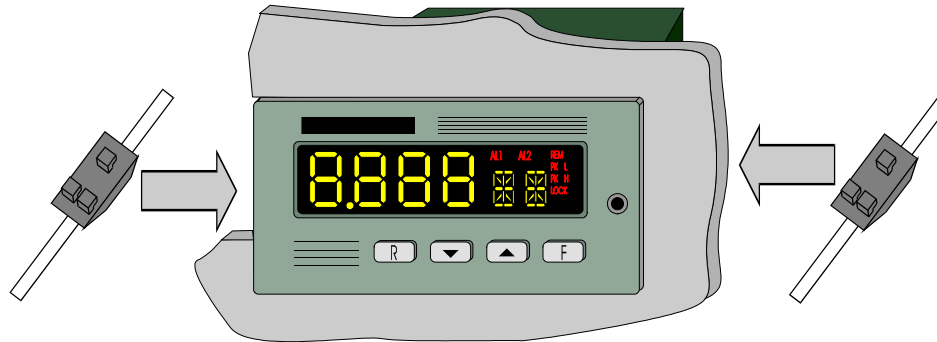

Fig. 2.1 HOW TO INSERT THE INSTRUMENT

2.2 WIRING GUIDE LINES

Connections are to be made with the instrument housing installed in its proper location.

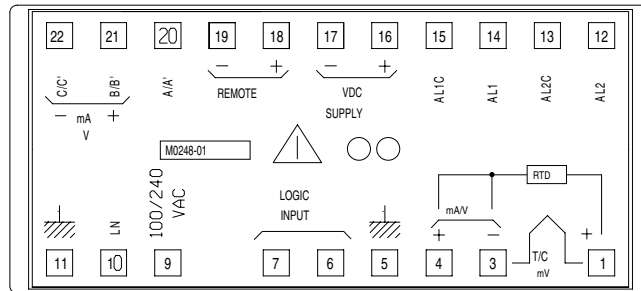

Fig. 2.2 REAR TERMINAL

A) POWER LINE

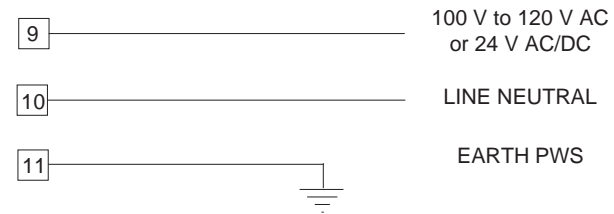

Fig. 2.3 POWER LINE WIRING

- NOTE: 1) Before connecting the instrument to the power supply, make sure that line voltage corresponds to lateral label indication.
 2) Terminal 11 must be connected to earth.
 3) To avoid electric shock, connect power supply at the end of the wiring procedure only.
 4) The power supply input has no fuse protection. Please, provide it externally.

B) INPUTS

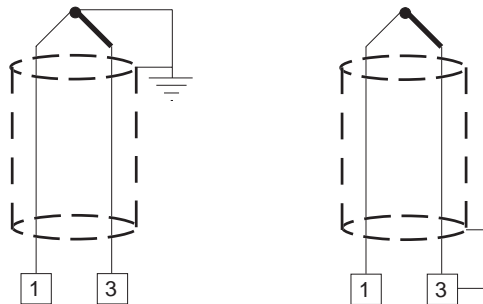

Fig. 2.4 THERMOCOUPLE INPUT WIRING

NOTE: Don't run input wires together with power cables.
Use proper compensating cable preferably shielded (see Table 1).
If shielded cable is used, the shield must be grounded at one point only.
Pay attention to the line resistance; a high line resistance may cause measurement errors (see PRODUCT SPECIFICATIONS).

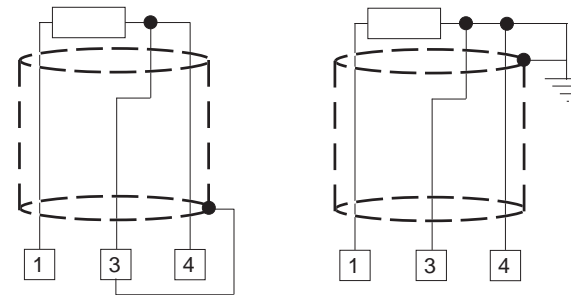

Fig. 2.5 RTD INPUT WIRING

NOTE: Don't run RTD wires together with power cables.
If shielded cable is used, the shield must be grounded at one point only.
Use copper wires with appropriate size (see "PRODUCT SPECIFICATIONS").
The resistance of the 3 wires must be the same.

Any external components (like zener barriers etc..) connected between sensor and input terminals may cause errors in measurement due to excessive and/or not balanced line resistance or possible leakage currents.

TABLE 1: THERMOCOUPLE COMPENSATING CABLE COLOUR CODES.

Thermocouple Material	British BS 1843	American ANSI MC 96.1	German DIN 43710	French NFE 18-001
T Copper Constantan	+ White - Blue Blue	+ Blue - Red Blue	+ Red - Brown Brown	+ Yellow - Blue Blue
J Iron Constantan	+ Yellow - Blue Black	+ White - Red Black	+ Red - Blue Blue	+ Yellow - Black Black
K Nichel Chromium Nichel Aluminium	+ Brown - Blue Red	+ Yellow - red Yellow	+ Red - Green Green	+ Yellow - Purple Yellow
R Platinum/ Platinum 13% Rhodium	+ Wite - Blue Green	+ Black - Red Green	+ Red - White White	+ White - Green Green
S Platinum/ Platinum 10% Rhodium	+ White - Blue Green	+ Black - red Green	+ Red - White White	+ White - Green Green
E Chromel Constantan	+ Brown - blue Brown	+ Violet - Red Violet	- - -	- - -
B Platinum 30% Rh Platinum 6 % Rh	- -	+ Grey - Red Grey	- -	- -
N Nicrosil / Nisil	-	-	-	-

2-wire transmitter without power supply

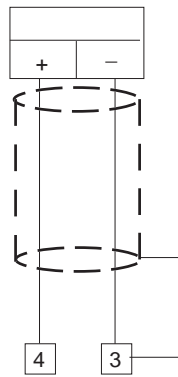

2-wire transmitter with power supply

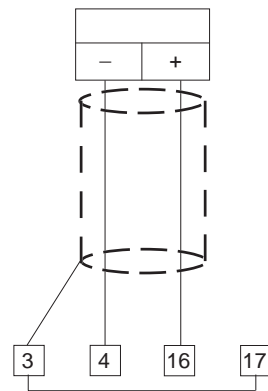

4-wire transmitter with power supply

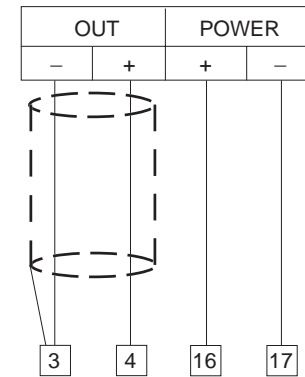

Fig 2.6 mA INPUT WIRING

NOTE: Don't run input wires together with power cables.

If shielded cable is used, the shield should be grounded at one point only (see fig. 2.6).

2-wire transmitter
without power supply

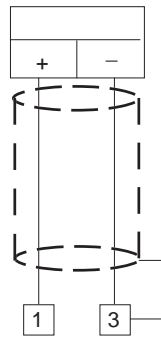
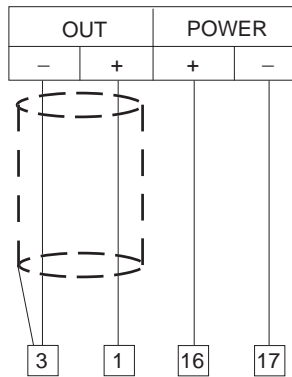

Fig. 2.7 mV INPUT WIRING

NOTE: Don't run input wires together with power cables.
Use proper cable preferably shielded.
If shielded cable is used, the shield must be grounded at one point only.
Pay attention to the line resistance; a high line resistance may cause measurement errors.

4-wire transmitter
with power supply



2-wire transmitter
without power supply

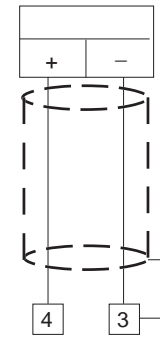
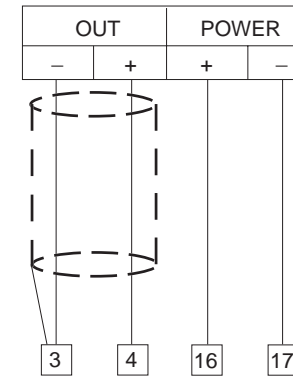

Fig. 2.8 V INPUT WIRING

NOTE: Don't run input wires together with power cables.
Use proper cable preferably shielded.
If shielded cable is used, the shield must be grounded at one point only.
Pay attention to the line resistance; a high line resistance may cause measurement errors.

4-wire transmitter
with power supply



C) EXTERNAL ALARM RESET OR HOLD FUNCTION

It is possible to reset both alarms of the instrument or hold the measured value by an external switch.



Fig. 2.9 - EXTERNAL ALARM RESET WIRING

D) LOCAL / REMOTE OPERATION

It is possible to operate the instrument in local mode or in remote mode. When the instrument is in remote mode it is under the control of a serial link.

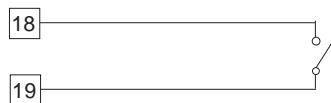

Fig. 2.10 LOCAL / REMOTE WIRING

E) OUTPUTS

E.1 ALARMS RELAY OUTPUT

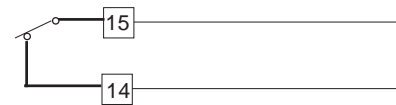

Fig. 2.11 ALARM 1 RELAY WIRING

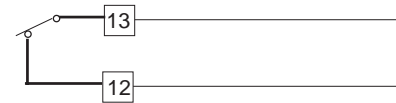

Fig. 2.12 ALARM 2 RELAY WIRING

The relay output is an SPST relay, protected with snubber network.

The contact ratings are: 2 A / 30 V DC on resistive load or
0.6 A / 110 V DC on resistive load or
0.5 A / 250 V AC on resistive load or
0.3 A / 110 V DC on inductive load.

The number of operations is 2×10^5 at specified rating.

E 1. INDUCTIVE LOADS

Switching inductive loads, high voltage transients may occur. These transients may damage the internal contacts, PCB or affect the performance of the instrument. In this case an external snubber network should be connected across the terminals as near as possible to the terminals (see Fig. 2.13).

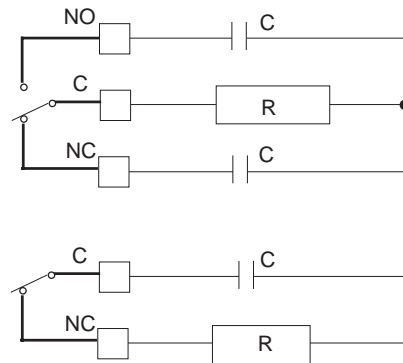

Fig. 2.13 EXTERNAL PROTECTION FOR INDUCTIVE LOAD GREATER THAN 40 mA AC

The value of capacitor (C) and resistor (R) are shown in the following table.

LOAD CURRENT	C (μF)	R (Ω)	RESISTOR POWER (W)	RESIST. AND CAPAC. VOLTAGE
< 40 mA	0.0022	100	1/2	260 V.A.C.
< 150 mA	0.1	22	2	260 V.A.C.
< 0.5 A	0.33	47	2	260 V.A.C.

The same problem may occur when a switch is used in series with the internal contacts as shown in Fig. 2.14

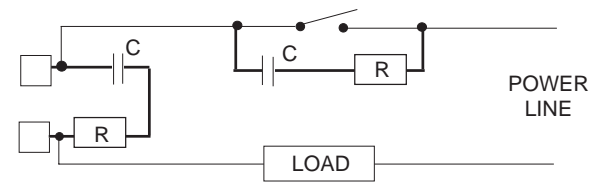

Fig. 2.14

In this case it should be better to protect the switch also as shown in Fig. 2.14. Anyway the cable involved in relay output wiring must be as far away as possible from input or communication cables.

E.1.2 EXTERNAL LOADS WITH VERY LOW HOLDING CURRENT

It may happen that the current flowing through the snubber network, when the contact is open, is sufficient to energize the external load (normally a contactor).

A similar problem may occur when driving solid state relay with the internal relay of the instrument.

The current flowing through the snubber network may keep the voltage across the SSR higher than the cutoff level.

In this case it is better to remove the snubber network or to connect, across the load, a resistor of appropriate value and power rating.

E.2 ANALOG RE-TRANSMISSION

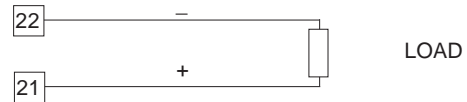

Fig. 2.15 ANALOG RE-TRANSMISSION WIRING

- NOTES :** 1) for mA output the maximum load impedance is 500 Ω .
2) For V output the minimum load impedance is 5000 Ω .

E.3 SERIAL INTERFACE

RS-485 interface allows to connect up to 31 instrument with the remote master unit. See Fig. 2.17.

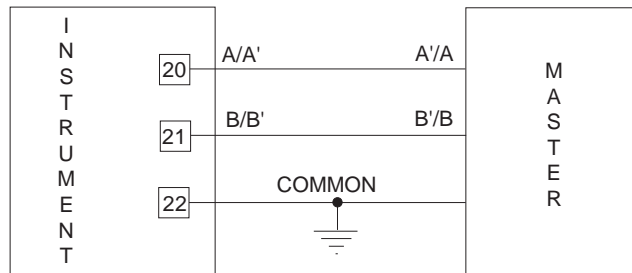

Fig. 2.16 - RS-485 WIRING

The cable length must not exceed 1.5 km at 9600 BAUD.

NOTE: The following report describes the signal sense of the voltage appearing across the interconnection cable as defined by EIA for RS-485.

- a) The "A" terminal of the generator shall be negative with respect to the "B" terminal for a binary 1 (MARK or OFF) state.
- b) The "A" terminal of the generator shall be positive with respect to the "B" terminal for a binary 0 (SPACE or ON)

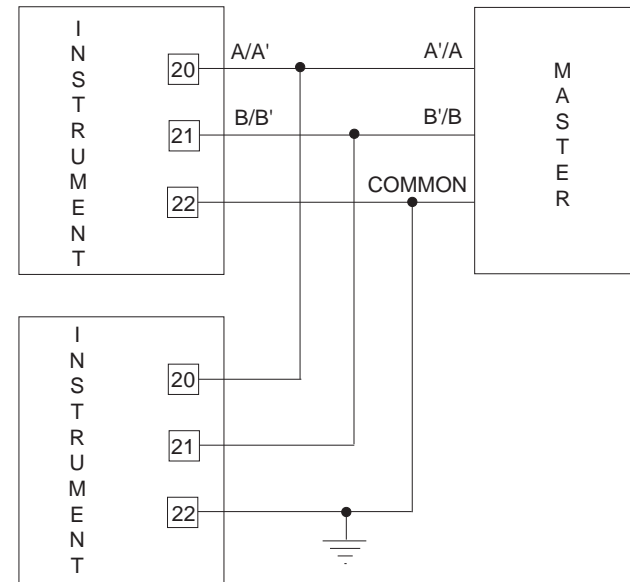

Fig. 2.17 - CONNECTION OF THE INSTRUMENTS (MAX 31) TO THE MASTER UNIT BY INTERFACE COMMUNICATION TYPE RS-485

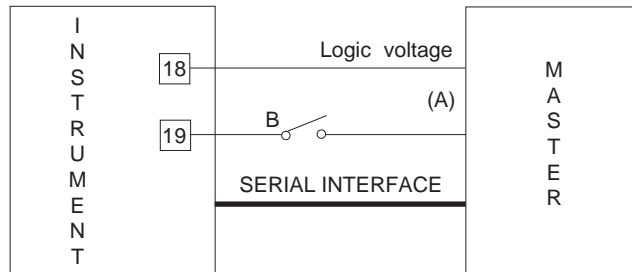

Fig. 2.18 - LOCAL/REMOTE CONTACT WIRING

A contact on the rear terminal block (terminals 18 and 19) is used to switch the instrument control from a master device to local mode or viceversa.

In case of emergency, the operator must regain control on the instrument by a switch (B) connected in series to the master control (A) and positioned near the instrument.

The switch should have a minimum rating of 0.5 mA - 12 V DC.



SECTION 3 INSTRUMENT CONFIGURATION

3.1 FRONT PANEL DESCRIPTION

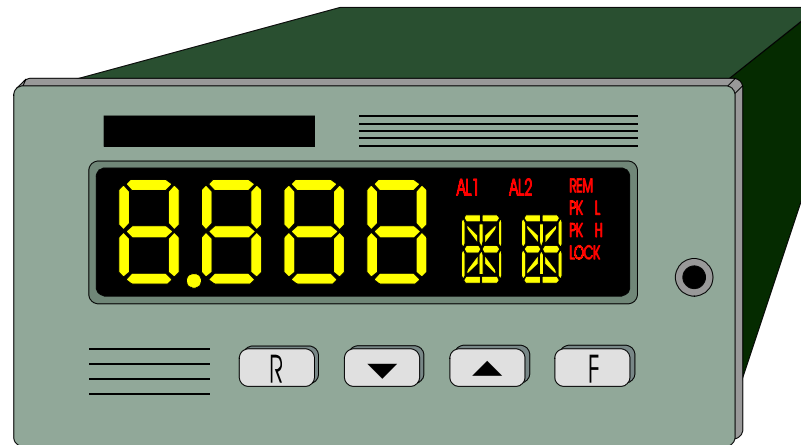

3.1.1 INDICATORS

AL 1 - AL 2

Indicator OFF = no alarm condition
Indicator ON = alarm condition

PK H

Indicator OFF = instrument shows the measured value
Indicator ON = instrument shows the "Peak high" value

PK L

Indicator OFF = instrument shows the measured value
Indicator ON = instrument shows "Peak low" value

LOCK

Indicator OFF = alarms threshold protection disabled
Indicator ON = alarms threshold protection enabled

REM

Indicator OFF = setting by serial communication interface disabled
indicator ON = setting by serial communication interface enabled

3.1.2 DISPLAYS

NUMERICAL DISPLAY

The numerical display shows continuously the process variable in eng. units.

During configuration and calibration set up, this display is used, in addition to the alphanumerical display, to show the parameters name and the relative value.

ALPHANUMERICAL DISPLAY

The alphanumerical display normally shows the engineering unit of the displayed value.

During configuration and calibration set up, this display is used, in addition to the numerical display, to show the parameters name and the relative value.

3.1.3 KEYBOARD DESCRIPTION



To increase the parameter value or select peak high visualization



To decrease the parameter value or select peak low visualization



To select all the parameters . Pushing the F pushbutton the parameters will be shown sequentially on the displays and, at the same time, the value of the previous parameter will be stored.



During configuration and calibration procedures and alarm threshold setting it is used to scroll back the parameters without memorization of the new values.

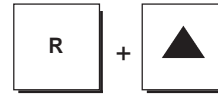

Alarm 1 manual reset

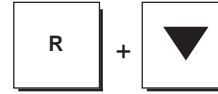

Alarm 2 manual reset



They are used to reset peak high and peak low and restart the peak detection procedure.



They are used to start the default parameters loading procedure.

3.2 INSTRUMENT CONFIGURATION

For configuration procedure, the internal DIP SWITCHES, mounted on CPU card, must be positioned as follows:

SW1 = OFF
SW2 = ON

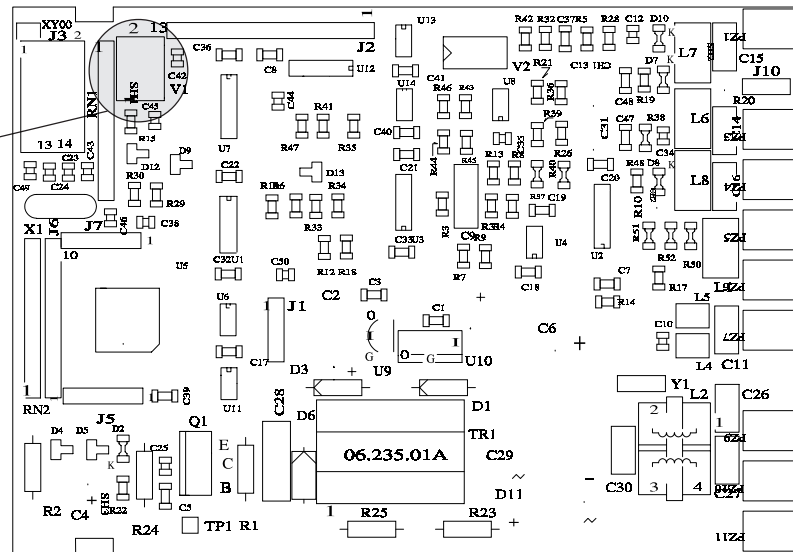

Fig. 3.1

3.2.1 PRELIMINARY HARDWARE SETTINGS

Before reassembling the instrument, make sure that all the necessary hardware settings are made as detailed below:

For the input selection, the dip switches V2 must be setted as follows

OUT \ V2	dip 1	dip 2	dip 3	dip 4
V	OFF	OFF	OFF	OFF
mA/TC/mV	OFF	OFF	ON	ON
RTD	ON	ON	OFF	OFF

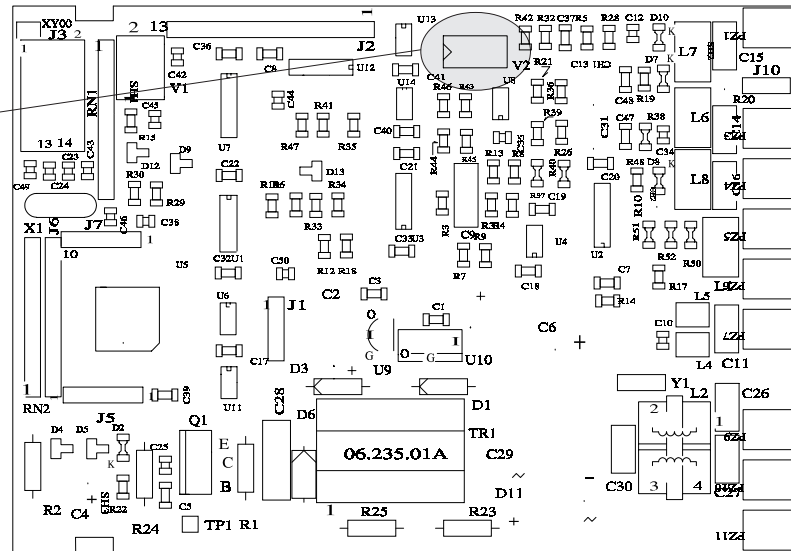

For alarms output, J250 and J251 must be set as follows:

Contact	NC	NO
AL 1	J250 = 1-2	J250 = 2-3
AL 2	J251 = 1-2	J251 = 2-3

NOTE : the alarm relays are energized in no alarm condition.

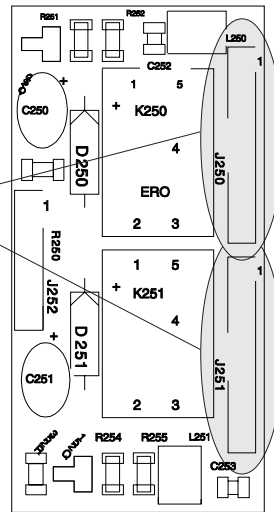

For auxiliary power supply set the jumpers J232, J233, J234, J235 and J236 as follows:

OUT Pos.	5 V output	10 V output	12 V output	24 V output
J232	close	open	open	open
J233	open	close	open	open
J234	open	open	close	open
J235	open	open	open	close
J236	2 - 3	2 - 3	2 - 3	1 - 2

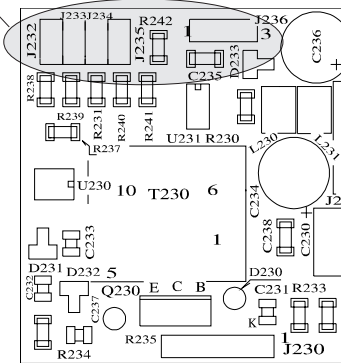

For analog retransmission, set the jumpers J104, J105 and J107 as follows:

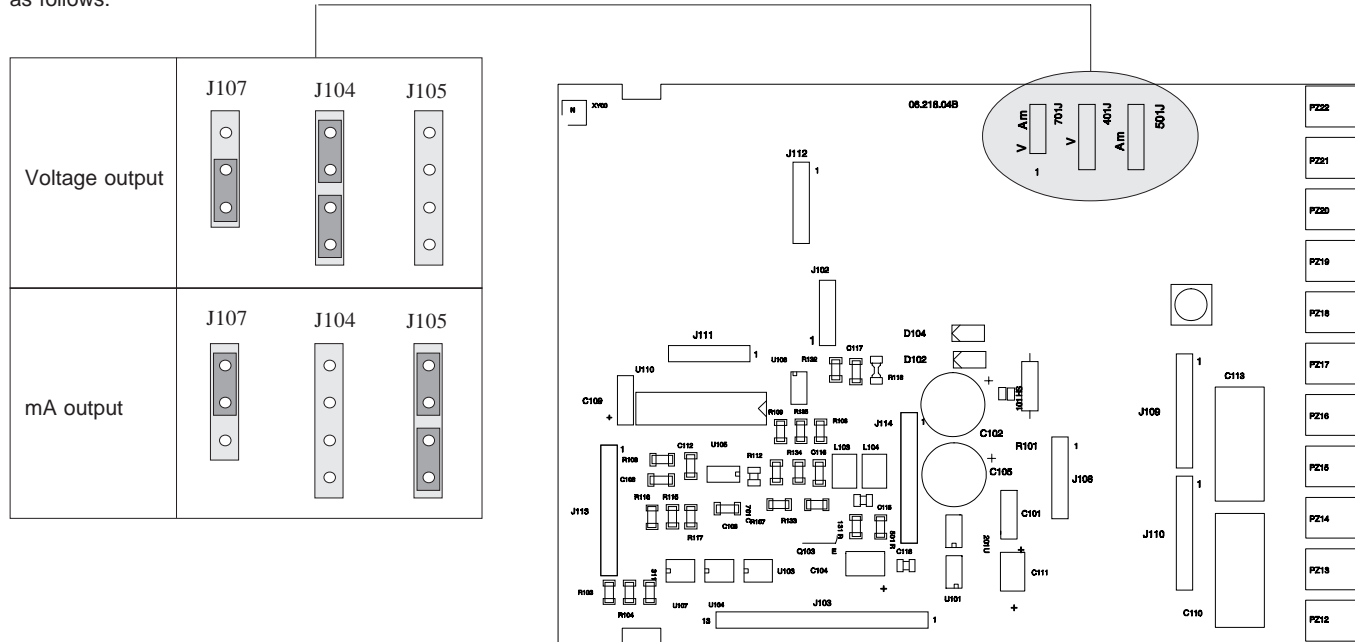

3.2.2 CONFIGURATION PROCEDURE

Once the internal dip switches have been positioned as described in Fig. 3.1 proceed as follows:

1. The display will show "CO nF"
NOTE: at this point it is possible to start the default parameter loading procedure as detailed at section 6
2. Push F pushbutton. The instrument shows the first parameter code and the relative value.
3. To modify this value push ▲ or ▼ to obtain the desired setting.

When the display shows the new desired setting, push F pushbutton to store the value and go to the next parameter.

It is possible to go back in the parameter sequence by using R pushbutton but, after parameters modification, push the F pushbutton otherwise the new value will not be stored (the storage is made only when the F pushbutton is depressed).

3.2.3 PARAMETERS LIST

The following is the complete parameters sequence.
Some parameters may not be shown according to the previous parameters setting.

1) POWER SUPPLY FREQUENCY

The display will show "LnE" followed by:

50 = 50 Hz

60 = 60 Hz

Push ▲ or ▼ pushbuttons to set the required frequency value.
Push the F pushbutton to memorize the new choice and go to the next parameter.

2) INPUT TYPE

The display will show "InP." followed by:

TC = thermocouple input (go to step 3)

RT = RTD input (go to step 3a)

Ln = linear input (go to step 4)

Fr = Frequency input (**NOT TO BE USE**)

Push ▲ or ▼ pushbuttons to set the required input type.
Push the F pushbutton to memorize the new choice and go to the next parameter.

NOTE: the input type selection shall be in accordance to the instrument type (see CODING at para. 1.4).

3) TC TYPE

The display will show "tc" followed by:

- K = NiCr/NiAl TC (IEC 584-1)
- J = Fe/CuNi TC (IEC 584-1)
- Jd = Fe/CuNi TC (DIN 43710 - 1977)
- E = NiCr/CuNi TC (IEC 584-1)
- T = Cu/CuNi TC (IEC 584-1)
- Td = Cu/CuNi TC (DIN 43710 - 1977)
- S = Pt10%Rh/Pt TC (IEC 584-1)
- R = Pt13%Rh/Pt TC (IEC 584-1)
- B = Pt30%Rh/Pt6%Rh TC (IEC 584-1)
- W = W/W26%Re TC
- W3 = W3%Re/W25%Re TC (STM - E 988 / 84)
- W5 = W5%Re/W26%Re TC (STM - E 988 / 84)
- N = Nicrosil/Nisil TC (IEC 584-1)
- NM = Ni/Ni18%Mo TC (G.E. Co.)
- PL = Platinel II (GHOST)

Push ▲ or ▼ pushbuttons to set the desired TC type.
Push the F pushbutton to memorize the new choice and go to the parameter 3b.

3.a) RTD TYPE

The display will show "rtd" followed by:

- PT = PT 100 Ω
- NI = Ni 100 Ω

Push ▲ or ▼ pushbuttons to set the desired RTD type.
Push the F pushbutton to memorize the new choice and go to the next parameter.

3.b) ENGINEERING UNIT

The display will show "En.Un" followed by:

- °F = Fahrenheit degree
- °C = Celsius degree

Push ▲ or ▼ pushbuttons to set the desired unit.
Push the F pushbutton to memorize the new choice and go to the next parameter.

3.c) BURN OUT

The display will show "FL.SF" followed by:

- Hi = when a burn out condition will be detected, the display will show "OPEN", peak detection, analog retransmission and alarms work as an over range condition.
- Lo = when a burn out condition will be detected, the display will show "OPEN"; peak detection, analog retransmission and alarms work as an under range condition.

Push ▲ or ▼ pushbuttons to set the desired condition.
Push the F pushbutton to memorize the new choice and go to the parameter 5.

4) LINEAR INPUT TYPE

The display will show "IN" preceded by:

0.20 = 0-20 mA
4.20 = 4-20 mA
0.60 = 0-60 mV
12.60 = 12-60 mV
0.5 = 0-5 V
1.5 = 1-5 V
0.10 = 0-10 V
2.10 = 2-10 V

Push ▲ or ▼ pushbuttons to set the desired range.
Push the F pushbutton to memorize the new choice and go to the next parameter.

4.a) SQUARE ROOT EXTRACTION

The display will show "SR" preceded by:

no = square root disabled
YES = square root enabled

Push ▲ or ▼ pushbuttons to set the desired solution.
Push the F pushbutton to memorize the new choice and go to the next parameter.

NOTE: If square root extraction is selected, the initial and final scale readouts must not be negative.

4.b) DECIMAL POINT POSITION

The display will show "dP" preceded by:

---- = no decimal figure
--.- = one decimal figure
-.-.- = two decimal figures
-.--- = three decimal figures

Push ▲ or ▼ pushbuttons to set the desired position.
Push the F pushbutton to memorize the new position and go to the next parameter.

4.c) INITIAL SCALE READOUT

The display will show "LR" preceded by a number between -1999 and 9999 .

This step allows to assign a readout value to the initial range value.
Push ▲ or ▼ pushbuttons to set the desired value (when the square root extraction is selected, the value must be positive).
Push the F pushbutton to memorize the new value and go to the next parameter.

4.d) FINAL SCALE READOUT

The display will show "HR" preceded by a number between -1999 and 9999 .

Push ▲ or ▼ pushbuttons to set the desired value (when the square root extraction is selected, the value must be positive).
Push the F pushbutton to memorize the new value and go to the next parameter.

4.e) ENGINEERING UNIT

The display will show "En.Un" followed by:

°C	= °C	nM	= normal m ³ /h
°F	= °F	A	= Ampere
PH	= pH	V	= Volt
KG	= Kg	W	= Watt
rPm	= Revolution per minute	m	= meter
PA	= Pascal	m3	=m ³
mB	= millibar	%	= Percent
B	= Bar	**	= Other

Push ▲ or ▼ pushbuttons to set the desired unit.

Push the F pushbutton to memorize the new choice and go to the next parameter.

If square root extraction is enabled, go to parameter 5.

4.f) BREAK POINTS NUMBER

The display will show "b.Pnt" followed by a number between 0 and 9.

Push ▲ or ▼ pushbuttons to set the desired value.

Push the F pushbutton to memorize the new value and go to the next parameter. If 0 value is selected, go to the parameter 5.

4.g) INPUT VALUE OF THE FIRST BREAK POINT

The display will show "I1" preceded by a number between 00.01 and 99.99 .

This number show the input value of the first break point in percent of the input span.

Push ▲ or ▼ pushbuttons to set the desired value.

Push the F pushbutton to memorize the new value and go to the next parameter.

4.h) READOUT VALUE OF THE FIRST BREAK POINT

The display will show "O1" preceded by a number between -1999 and 9999 .

This number show the readout value associate to the input value set at par. 4.g.

Push ▲ or ▼ pushbuttons to set the desired value.

Push the F pushbutton to memorize the new value and go to the next parameter.

NOTE: For the other break points the instrument repeats the cycle 4.g - 4.h so many times as programmed at point 4.f.

GENERAL NOTE ON LINEARIZATION BY BREAK POINT

A) The instrument start to visualize the break point and the relative value previously memorized.

If the break point value is not acceptable in relation to the previous break point, the alphanumerical display flashes and, pushing ▲ or ▼ pushbuttons, the instrument goes immediately to the first acceptable value.

B) The low limit of the input break point is 0.01 more than the previous input break point while the upper limit is 99.99.

Readout

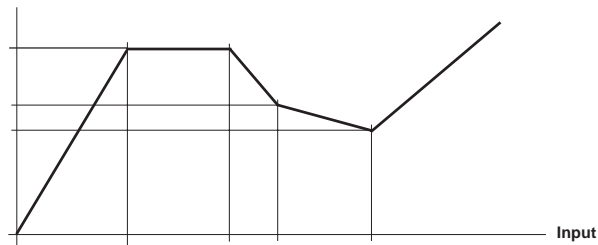

5) DIGITAL FILTER ON READOUT VALUES

The display will show "FILt" followed by a number.

Using ▲ and ▼ pushbutton it is possible to select the desired time constant for the digital filter in order to obtain a stable readout in presence of noise also. The possible choices are 0.4, 1, 2, 3, 4 or 5 s.

Push the F pushbutton to memorize the new choice and go to the parameter 7.

NOTE: this filter is disabled for the instruments with frequency input.

6) FREQUENCY SETTING

The DPS with frequency input is not yet available so that all the informations related with frequency input setting are skipped.

7) EXTERNAL CONTACT FUNCTION

This step allows to select the function enabled and disabled by the external contact.

The display will show "EX" preceded by:

"HOLd" = sampling stop and the instrument maintains the actual displayed value while the eng. unit will flash.

"n.RES" = manual reset of the alarms.

Push ▲ or ▼ pushbuttons and set the desired function.

Push the F pushbutton to memorize the new choice and go to the next parameter.

7.a) CONTACT STATUS

With this parameter is possible to define the external contact status for function enabling.

The display will show "EX" preceded by:

"CLSD" = enabled with closed contact.

"OPEn" = enabled with open contact.

Push ▲ or ▼ pushbuttons and set the desired status.

Push the F pushbutton to memorize the new status and go to the next parameter.

8) OPTIONS

The display will show "OPtn" followed by:

- 0 = no option provided (go to step 15)
- 1 = 2 alarms (go to step 11)
- 2 = 2 alarms plus serial interface (go to step 10)
- 3 = 2 alarms plus analog retransmission (go to step 9)

Push ▲ or ▼ pushbuttons and set the desired options.
Push the F pushbutton to memorize the new configuration and go to the next parameter.

9) ANALOG RETRANSMISSION TYPE

The display will show "out" preceded by:

- 0 - 20 = output 0 - 20 mA
- 4 - 20 = output 4 - 20 mA
- 0 - 10 = output 0 - 10 V

Push ▲ or ▼ pushbuttons and set the desired output.
Push the F pushbutton to memorize the new set and go to the next parameter.

NOTE: If the transfer from mA to V or vice versa is desired, it is necessary to recalibrate the instrument as detailed in para. 5.3.

9.a) RETRANSMISSION MINIMUM SCALE VALUE

The display will show "LR" preceded by a number between -1999 and 9999.

The decimal point is positioned as programmed at step 4b or 6a.
No decimal point is provided for TC or RTD inputs.

Push ▲ or ▼ pushbuttons and set the desired value. Push the F pushbutton to memorize the new value and go to the next parameter.

9.b) RETRANSMISSION MAXIMUM SCALE VALUE

The display will show "HR" preceded by a number between -1999 and 9999. Push ▲ or ▼ pushbuttons and set the desired value. Push the F pushbutton to memorize the new value and go to the next parameter.

9.c) DIGITAL FILTER ON THE ANALOG RETRANSMISSION

The display will show "FILt" followed by a number.

Using ▲ and ▼ pushbutton it is possible to select the same time constant selected for readout or the exclusion of the filter (0 setting).

Push the F pushbutton to memorize the new value and go to the parameter 11.

10) SERIAL INTERFACE ADDRESS

The display will show "Ad" preceded by a number.

Using ▲ and ▼ pushbutton it is possible to select the desired instrument address from 0 to 31.

The 0 value disables the serial communication interface

Push the F pushbutton to memorize the new value and go to the next parameter.

If 0 value is selected the instrument will go to parameter 11.

10.a) BAUD RATE

The display will show "bd" preceded by a number.

Using ▲ and ▼ pushbutton it is possible to select the desired instrument baud rate from 150 to 19200 baud.

The speed of 19200 baud will be only shown in kbaud (19.2).

Push the F pushbutton to memorize the new value and go to the next parameter.

10.b) BYTE FORMAT

The display will show "bF" preceded by:

7E = 7 bit + even parity

7O = 7 bit + odd parity

8E = 8 bit + even parity

8O = 8 bit + odd parity

8 = 8 bit no parity

Using ▲ and ▼ pushbuttons it is possible to select the desired byte format.

Push the F pushbutton to memorize the new choice and go to the next parameter.

11) ALARM 1 TYPE

The display will show "OP.A1" followed by:

L.L. = low latched alarm (manual reset)

L.A. = low alarm with automatic reset

H.L. = high latched alarm (manual reset)

H.A. = high alarm with automatic reset

Using ▲ and ▼ pushbuttons it is possible to select the desired type of alarm and the relative reset.

Push the F pushbutton to memorize the new configuration and go to the next parameter.

11.a) ALARM 1 HYSTERESIS

The display will show "HS.A1" followed by a number from 0.1 to 5.0. It show alarm one hysteresis in percent of the readout span.

Using ▲ and ▼ pushbuttons it is possible to select the desired hysteresis value.

Push the F pushbutton to memorize the new value and go to the next parameter.

12) ALARM 2

Same as alarm 1

13) FILTER ON THE ALARM THRESHOLD

The display will show "FILt" followed by a number.

Using ▲ and ▼ pushbuttons it is possible to select the same time constant selected for readout or the exclusion of the filter (0 setting).

Push the F pushbutton to memorize the new choice and go to the next parameter.

14) SAFETY LOCK

The display will show "KY" preceded by:

- 0 = no threshold protection. The alarm threshold may be modified in every moment during operating mode.
- 1 = Ever active protection. Alarm threshold couldn't be modified.
- 2 - 9999= This value is a secret value and it could be necessary to put the instrument in unlock condition and modify alarm threshold during operative mode.

NOTE: When safety lock is selected, the secret value cannot be displayed again.

It is important to record the secret value accurately.

If the secret value is lost, a new value should be set.

15) END

At the end of configuration procedure the display will show "COnt" and it is possible to review the parameter setting or go to the operating mode.



SECTION 4 OPERATING INSTRUCTIONS

4.1 PRELIMINARY

After the configuration procedure, it is possible to make the DPS operative by setting the internal dip switches mounted on CPU (see Fig. 3.1 at page 3.4) as follows:

- 1 = OFF
- 2 = OFF



Now switch ON the instrument.

4.2 OPERATIVE MODE

The alarms and key visualization and the setting-up procedure are checked by a time out of 10 s. approx. If during this time no other pushbutton has been pushed, the display will return to show the measured variable and the last change will not be stored.

NOTES: The R pushbutton is used to scroll back the parameters without memorization of the new values.
A wrong setting may be deleted by R pushbutton pressure.

4.2.1 PEAK HIGH AND PEAK LOW VISUALIZATION

Usually the display show the measured value and its engineering unit.

Pushing ▲ pushbutton it is possible to visualize the maximum peak value (peak high) measured by the instrument (the "PK H" indicator will light).

Pushing ▼ pushbutton it is possible to visualize the minimum valley value (peak low) measured by the instrument (the "PK L" indicator will light).

The memorization of the peak high and peak low values starts, automatically, when switching on the instrument and can not be stopped.

To clear the previous values, push R and F pushbuttons contemporarily.

Note : this visualization do not disappear after time out.
Push ▲ or ▼ pushbutton in order to display the measured value.

4.2.2 MANUAL RESET OF THE ALARMS

If the alarm has been configured as a latched alarm, the alarm status ("ALx" indicator lit and relay deenergized) persists also after the alarm condition disappears.

Pushing R and ▲ pushbuttons contemporarily it is possible to reset the alarm 1 status.

Pushing R and ▼ pushbuttons contemporarily it is possible to reset the alarm 2 status.

When the remote alarm reset is programmed (see section 3 step 7) it will be possible to reset both alarms by an external contact.

The alarm reset action will be successful if the alarm condition has disappeared only.

4.2.3 ALARMS THRESHOLD SETTING

The visualization of the alarms threshold is always possible while its modification must be done in accordance to the programmed safety lock.

Different situations may occur:

A) The LOCK indicator is lit. Proceed as follows:

A.1) Push the F pushbutton. The display show "A1" preceded by alarm 1 threshold value.

In this case, the alarm threshold can't be modified unless a modification of the safety lock value is made in configuration procedure.

A.2) Push the F pushbutton. The alphanumerical display will show "KY" preceded by four lines.

Push ▲ or ▼ pushbuttons and set the safety key value.

Pushing the F pushbutton the LOCK indicator goes OFF and the display will show "A1" preceded by alarm 1 threshold value.

Proceed as detailed in step B).

B) The LOCK indicator is OFF. Proceed as follow:

B.1) Push the F pushbutton. The alphanumerical display will show "KY" preceded by four lines.

Go to step B.2.

B.2) Pushing F pushbutton the alarm threshold will be shown on the numerical display while alphanumerical display will show "A1".
Push ▲ or ▼ pushbuttons and set the desired value.
Pushing the F pushbutton the new alarm 1 threshold will be stored and alarm 2 threshold will be shown.
Push ▲ or ▼ pushbuttons and set the desired value.
Pushing the F pushbutton the new alarm 2 threshold will be stored and the instrument returns to normal operation.

- NOTE:**
- 1) The alarm threshold modification is limited by minimum and maximum readout
 - 2) For frequency input and Hz readout the maximum input range is 0 - 50,000 Hz and also threshold setting is auto-ranging.

NOTE: for safety lock enabling proceed as follows:

Push the F pushbutton. The alphanumerical display will show "KY" preceded by four lines.
Push ▲ or ▼ pushbuttons and set any value different from the safety key value.
Push F pushbutton; the LOCK indicator will light to show the lock is enabled.

4.2.4 HOLD FUNCTION

The HOLD function allows to stop data acquisition and hold the displayed value.

When the hold function is enabled, the engineering unit on the alphanumerical display is flashing.

Both alarms continue to operate according to the stopped displayed value.

The analog and digital retransmissions continue to retransmit the displayed value.

In order to use the HOLD function, proceed as follow:

- 1) make the connection shown at step C) paragraph 2.2 (see chapter 2 "INSTALLATION").
- 2) Set the "EX" parameter as shown at step 7) and 7.a) paragraph 3.2.3 (see chapter 3 "INSTRUMENT CONFIGURATION").

SECTION 5 INSTRUMENT CALIBRATION PROCEDURES

5.1 DIP SWITCHES LOCATION

To start with the calibration procedure, the internal DIP SWITCHES, mounted on CPU card, must be positioned as shown at left:

NOTE: during calibration procedure the serial communication interface will be disabled.

SW1 = ON
SW2 = OFF

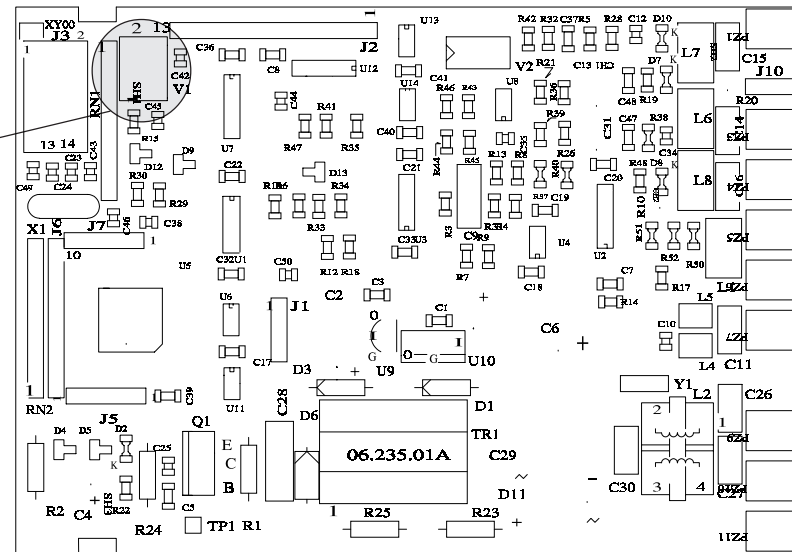

Fig. 5.1

5.2 GENERAL GUIDE LINES FOR CALIBRATION

For a good calibration it is necessary to proceed as follows:

- a) - The instrument under calibration should be mounted in its case in order to keep the internal temperature constant.
- b) - The ambient temperature should be stable.
Avoid any drift due to air-conditioning or others.
- c) - The relative humidity should not exceed 70%.
- d) - Minimum warm-up time must be 20 minutes.
- e) - Operate possibly in a noise free environment.
- f) - During calibration, connect one input at a time and supply the input signal when the group is enabled only.

For this calibration procedure it is necessary to use calibrators with the following accuracy and resolution:

ACCURACY

- 1) For TC, mV or V input: $\pm 0.005\%$ output $\pm 0.001\%$ range $\pm 5 \mu\text{V}$
- 2) For current input: $\pm 0.025\%$ output $\pm 0.0025\%$ range $\pm 0.01 \mu\text{A}$
- 3) For RTD input: $\pm 0.02\%$ $\pm 0.0025 \Omega/\text{decade}$.
- 4) For Cold junction compensation: better than $0.1 \text{ }^\circ\text{C}$

RESOLUTION

- 1) For TC, mV input: $1 \mu\text{V}$
- 2) For current input: $0.2 \mu\text{A}$
- 3) For RTD input: $10 \text{ m}\Omega$
- 4) For cold junction compensation: better than $0.1 \text{ }^\circ\text{C}$
- 5) For V input : $100 \mu\text{V}$

5.3 CALIBRATION PROCEDURE

5.3.1 FOREWORD

During calibration procedure the instrument will show CL and CH parameters if analog retransmission is selected only.

For frequency input type, no calibration procedures are provided.

NOTE: Calibration parameters are logically divided in groups of two parameters each (initial and final scale value).

After each group the calibration check is provided but it is also possible to do it without a new calibration is made.

When calibration check is required only, press twice the F pushbutton when "OFF" is shown on the display. The instrument goes directly to the specific group check.

The alphanumeric display will show the parameter code (C -) while the numerical display will show "ON" or "OFF".

Using ▲ and ▼ pushbuttons it is possible to select between "ON" or "OFF".

To go to the next parameter without modify the calibration, push F pushbutton when the display is showing "OFF" .

To set parameter calibration, push F pushbutton when the display show "ON".

NOTE: Pushing R pushbutton it is possible to go back to the previous parameter without modify the calibration.

5.3.2 CALIBRATION PROCEDURE

All the instruments are originally calibrated by means of calibrators with high accuracy and resolution (see para. 5.2).

The instrument are calibrated for inputs and output specifies in ordering code only (see para. 1.4).

When the display shows "CAL" it is possible to load the default parameter as detailed in section 6

Follows a list of calibration symbols:

Code	Parameter
C 0	- Current input minimum range value (0 mA)
C 1	- Current input maximum range value (20 mA)
C 2	- Voltage input minimum range value (0 V)
C 3	- Voltage input maximum range value (5 V)
C 4	- Voltage input minimum range value (0 V)
C 5	- Voltage input maximum range value (10 V)
C 6	- TC, mV input minimum range value (0 mV)
C 7	- TC, mV input maximum range value (60 mV)
C 8	- RTD input minimum range value (0 Ω)
C 9	- RTD input maximum range value (500 Ω)
C J	- Cold junction compensation
C L	- Analog retransmission minimum range value
C H	- Analog retransmission maximum range value

NOTE: apply only appropriate input signal when calibration or checking code are displayed .

HOW TO PROCEED

Push the F pushbutton to visualize the first calibration symbol on the display. Depress, in sequence, F pushbutton until the desired calibration symbol is reached.

C 0 - CURRENT INPUT MINIMUM RANGE VALUE

- Connect the instrument to the calibrator as shown in Fig. 5.2.
- Set 0.000 mA DC on the calibrator (even if the minimum range value is 4 mA).
The display will show "OFF".
Depress ▲ pushbutton to enable the calibration; then the display will switch to "ON".
- Wait few seconds, until the measurement has stabilized.
- Push the F pushbutton; the numerical displays will blank and only the decimal point of the right hand figure of the numerical display will be lit. When the calibration is completed the instrument will go automatically to the next parameter.

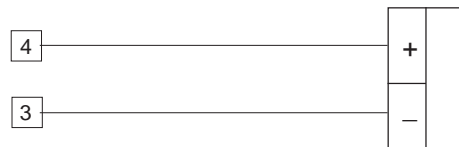

Fig. 5.2

C 1 - CURRENT INPUT MAXIMUM RANGE VALUE.

- Set 20,000 mA on the calibrator (see Fig. 5.2).
- Push ▲ pushbutton, the display will show "ON" and "C 1" will remain on the alphanumerical display.
- Wait few seconds then push F pushbutton.
- The numerical displays will blank temporarily to show that the instrument is performing the calibration routine.

CURRENT INPUT CHECK

- The instrument will show "A" preceded by a number showing the measured value in counts.
Set 20.000 mA on the calibrator, if C 1 calibration is correct the indication will be "25000A" ± 10 counts.
- Check the zero calibration by resetting the calibrator to 0.000 mA.
The resulting indication should give "00000A" ± 10 counts.
Check the linearity by setting the calibrator to 10.000 mA; the readout must be "12500A" ± 10 counts.
- Push F for the next calibration

C 2 - 0 - 5 V INPUT MINIMUM RANGE VALUE

- a) Connect the instrument to the calibrator as shown in Fig. 5.3.
- b) Set 0.000 V DC on the calibrator (even if the minimum range value is 1 V).
The display will show "OFF".
Depress \blacktriangle pushbutton to enable the calibration; then the display will switch to "ON".
- c) Wait few seconds, until the measurement has stabilized.
- d) Push the F pushbutton; the numerical displays will blank and only the decimal point of the right hand figure of the numerical display will be lit. When the calibration is completed the instrument will go automatically to the next parameter.

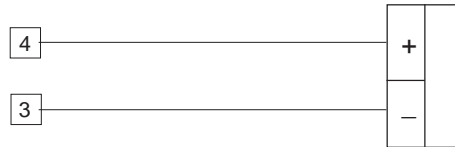

Fig. 5.3

C 3 - 0 - 5 V INPUT MAXIMUM RANGE VALUE.

- a) Set 5,000 V on the calibrator (see Fig. 5.3).
- b) Push \blacktriangle pushbutton, the display will show "ON" and "C 3" will remain on the alphanumerical display.
- c) Wait few seconds then push F pushbutton.
- d) The numerical displays will blank temporarily to show that the instrument is performing the calibration routine.

0 - 5 V INPUT CHECK

- a) The instrument will show "B" preceded by a number showing the measured value in counts.
Set 5.000 V on the calibrator, if C 3 calibration is correct the indication will be "25000B" ± 10 counts.
- b) Check the zero calibration by resetting the calibrator to 0.000 V.
The resulting indication should give "00000B" ± 10 counts.
Check the linearity by setting the calibrator to 2.500 V; the readout must be "12500B" ± 10 counts.
- c) Push F for the next calibration

C 4 - 0 - 10 V INPUT MINIMUM RANGE VALUE

- a) Connect the instrument to the calibrator as shown in Fig. 5.4.
- b) Set 0.000 V DC on the calibrator (even if the minimum range value is 2 V).
The display will show "OFF".
Depress \blacktriangle pushbutton to enable the calibration; then the display will switch to "ON".
- c) Wait few seconds, until the measurement has stabilized.
- d) Push the F pushbutton; the numerical displays will blank and only the decimal point of the right hand figure of the numerical display will be lit. When the calibration is completed the instrument will go automatically to the next parameter.

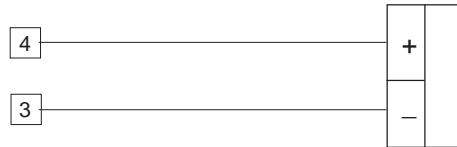

Fig. 5.4

C 5 - 0 - 10 V INPUT MAXIMUM RANGE VALUE.

- a) Set 10,000 V on the calibrator (see Fig. 5.4).
- b) Push \blacktriangle pushbutton, the display will show "ON" and "C 3" will remain on the alphanumerical display.
- c) Wait few seconds then push F pushbutton.
- d) The numerical displays will blank temporarily to show that the instrument is performing the calibration routine.

0 - 10 V INPUT CHECK

- a) The instrument will show "C" preceded by a number showing the measured value in counts.
Set 10.000 V on the calibrator, if C 5 calibration is correct the indication will be "25000C" ± 10 counts.
- b) Check the zero calibration by resetting the calibrator to 0.000 V.
The resulting indication should give "00000C" ± 10 counts.
Check the linearity by setting the calibrator to 5.000 V; the readout must be "12500C" ± 10 counts.
- c) Push F for the next calibration

C 6 - TC, mV INPUT MINIMUM RANGE VALUE

- Provide connections between calibrator and instrument under test as shown in Fig. 5.5.
- The numerical display will show "OFF", while "C 6" will appear on the alphanumerical display.
- Set calibrator to 0.000 mV. Push ▲ pushbutton, the display will change to "ON".
- After few seconds, start calibration by pushing F pushbutton, the display will blank and only the decimal point will appear on the display.

At the end of this calibration routine, the instrument will go to the next parameter.

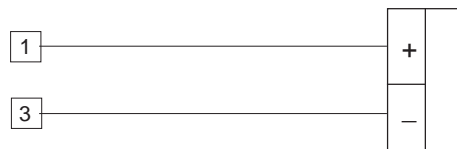

Fig. 5.5

C 7 -TC, mV INPUT - MAXIMUM RANGE VALUE

- Set the calibrator to 60.000 mV (see Fig. 5.5).
- Push ▲ pushbutton, the displays will show "ON" and "C 7".
- Wait few seconds then push F pushbutton.
- The numerical displays will blank temporarily to show that the instrument is performing the calibration routine.

TC INPUT CHECK

Then the display will show "D" preceded by a number showing the measured value in counts.

C7 calibration is correct if the indication is "25000 D" \pm 10 counts.

- Check the zero calibration, by setting the calibrator to 0.000 mV, the readout must be "00000D" \pm 10 counts.
- Check linearity at half scale by setting 30 mV on the calibrator. The readout must be "12500D" \pm 10 counts.
- Push F pushbutton, and go to the next calibration.

C 8 - RTD INPUT MINIMUM RANGE VALUE

- a) Connect a resistor box as shown in Fig. 5.6.
- b) Set 0.00 Ω on the resistor box.
- c) Push \blacktriangle pushbutton, then the instrument will show "ON" and "C 8".
- d) After few seconds, start calibration routine by pushing F pushbutton. The decimal point of least significant digit on the numerical display will light to indicate that the instrument is performing calibration. Then the displays will show "OFF" and "C 9".

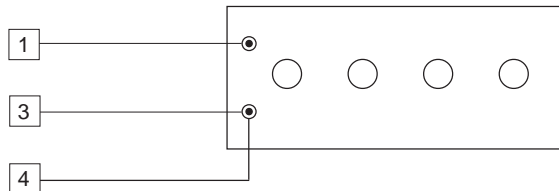

Fig. 5.6

C 9 - RTD INPUT MAXIMUM RANGE VALUE

- a) Set the resistance box to 500.00 Ω (see Fig. 5.6).
- b) Push \blacktriangle pushbutton, the displays will show "ON" and "C 9".
- c) Wait few seconds then push F pushbutton.
- d) The numerical displays will blank temporarily to show that the instrument is performing the calibration routine.

RTD INPUT CHECK

- a) The display will show "25000 Ω " ± 10 counts otherwise set the resistance box to 500.00 Ω (see Fig. 5.6)
The C9 calibration is correct if the indication is "25000 Ω " ± 10 counts.
- b) Check the zero calibration by setting 0.00 Ω on the resistance box; the readout must be "00000 Ω " ± 10 counts.
To check the half scale linearity, set the resistance box to 250.00 Ω and the readout should be "12500 Ω " ± 10 counts.
- c) Push F pushbutton to proceed to next calibration step.

C J COLD JUNCTION COMPENSATION

NOTE: make sure that C6 and C7 parameters are correctly calibrated before CJ calibration.

- Measure the temperature close to terminals 1 and 3 using an appropriate instrument, for instance, a MEMOCAL.
- Wait a few minutes to allow the temperature stabilization of entire the system (compensation cable, sensor, calibrator and instrument).
- The displays will show "C J" and "25.0".

NOTE: This value is only a default value and it not represents the real measurement.

Using ▲ or ▼ pushbuttons, make the readout value equal to the temperature measured by the measuring device in tenth of °C. The display will show an half zero at the most significant digit to indicate the ON calibration condition.

- Initiate the calibration routine by pushing F pushbutton.

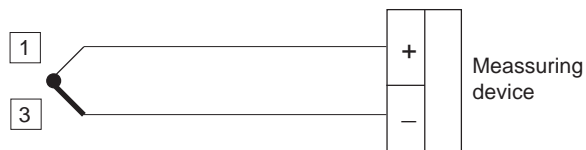

Fig. 5.7

COLD JUNCTION COMPENSATION CHECK

The display will show "RJ" and the cold junction temperature in tenths of °C.

Make sure that the display readout is equal to the value read on the measuring device (MEMOCAL).

Push F pushbutton to proceed to next calibration step.

C L - ANALOG RETRANSMISSION MINIMUM RANGE VALUE

- Connect the instrument as shown in Fig. 5.8.

- Set J104, J105 and J107 on the option card as follow:

Retransmission type	Jumpers		
	J104	J105	J107
Current	OPEN	CLOSED	2 - 3
Voltage	CLOSED	OPEN	1 - 2

- The alphanumerical display shows "C L" and the numerical display shows a number of counts.

- Using ▲ or ▼ pushbuttons, adjust the instrument output until $0.000\text{mA} \pm 0.015\text{ mA}$ or $00.00\text{V} \pm 0.0073\text{ V}$ is shown by the measuring device.

- d) Depress F pushbutton. The instrument memorizes the above value as zero.
The display will show now "C H" which means that the instrument is ready for next calibration step.

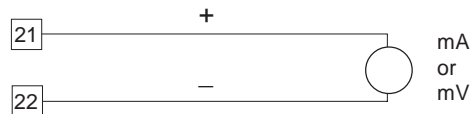

Fig. 5.8

- NOTE:** 1) The minimum value must be calibrated at 0 mA even if the output is 4 - 20 mA.
2) For current output only, the D/A converter of the instrument is not able to generate a negative signal; therefore, during the calibration of this parameter, make the instrument to generate a positive signal (by the ▲ pushbutton), then decrease slowly the output signal (by ▼ pushbutton) until the lower value appears on the display.

C H - ANALOG RETRANSMISSION MAXIMUM RANGE VALUE

- a) Push ▲ and ▼ pushbuttons until the output of the instrument is $20.000 \text{ mA} \pm 0.015 \text{ mA}$ or $10 \text{ V} \pm 0.0075 \text{ V}$.
b) Memorize this calibration by pushing F pushbutton.

With this last operation the instrument returns at the beginning of the calibration routine.
Switch off the instrument and set the dip switches according to para. 4.1.



SECTION 6 DEFAULT PARAMETERS SETTING

6.1 PRELIMINARY

The instrument is delivered with a default parameters sets stored and usable, in every moment, for clear all the memories. Different parameters sets are provided for configuration, calibration and operative modes but the memorization follows the same procedure. During every particular working mode it is possible to load only the parameters of the specific mode.

6.2 DEFAULT PARAMETERS SETTING

Push ▲ pushbutton and, maintaining the pressure, push ▼ pushbutton. The display will show "OFF" and "dF". Pushing ▲ pushbutton, on the display will appear "ON". Push F pushbutton to start default parameters loading. During this routine the display will show "LOAD" and "dF". After loading routine the instrument will return to the initial status.

6.3 DEFAULT CONFIGURATION PARAMETERS

1	Power supply frequency	50 Hz
2	Input type	TC
3	TC type	K
3.a	RTD type	Pt 100 Ω
3.b	Engineering unit	°C
3.c	Burn-out	Over range
4	Linear input type	4-20 mA
4.a	Square root extraction	Disabled
4.b	Decimal point position	None
4.c	Initial scale readout	-1999
4.d	Final scale readout	9999
4.e	Engineering unit	°C
4.f	Break points number	0
4.g	Break points inputs	with 10% step
4.h	Break points readouts	with 10% step
5	Readout digital filter	0.4 s
6	NOT USED	
7	External contact function	HOLD
7.a	Contact status	Closed
8	Options	None
9	Analog retransmission type	4-20 mA

9.a	Retransmission minimum scale value	-1999
9.b	Retransmission maximum scale value	9999
9.c	Digital filter on the analog retransmission	None
10	Serial interface address	00
10.a	Baud rate	19200
10.b	Byte format	7bit + even parity
11	Alarm 1 type	High alarm with automatic reset
11.a	Alarm 1 hysteresis	0.1 %
12	Alarm 2 type	low alarm with automatic reset
12.a	Alarm 2 hysteresis	0.1 %
13	Digital filter on the alarm threshold	None
14	Safety lock	0

6.4 DEFAULT CALIBRATION PARAMETERS

The default calibration parameters allow to verify the correct working of the instrument but they are not calibration parameters.

NOTE: After default calibration parameters loading, it is necessary to recalibrate the instrument.

6.5 DEFAULT OPERATIVE PARAMETERS

Alarm 1 threshold	initial scale readout
Alarm 2 threshold	initial scale readout

SECTION 7 ERROR MESSAGES

7.1 OUT OF RANGE

The instrument shows the UNDER RANGE and the OVER RANGE with the following messages on the numerical display:



OVER RANGE



UNDER RANGE

During out of range indications, alarm status, peak detection and analog retransmission operate as in presence of the range limits.

- NOTE:**
- 1) The out of range indications follow the readout scaling so that when a reverse scaling is set, over range and under range are reversed also.
 - 2) The out of range indication is shown when the input signal is 2% higher or 2% lower of the max. and min. scale values respectively.

To eliminate the OUT OF RANGE condition, proceed as follows:

- 1) Check the input signal source and the connecting line.
- 2) Make sure that the input signal is in accordance with instrument configuration. Otherwise, modify the input configuration (see chapter 3.2).
- 3) Send back the instrument to your supplier for a check.

7.2 OPEN INPUT CIRCUIT

This instrument is able to identify the open circuit for 4-20 mA, 1-5 V, 2-10 V, TC and RTD inputs.

The open input circuit condition is shown by "OPEn" on the numerical display.

If TC or RTD input is selected, it is possible to set, in configuration procedure, the outputs status associated to the open input condition. (see para. 3.c)

For mA and V input the instrument associates this status to under range condition .

NOTE: For 4 - 20 mA, 1-5 V and 2-10 V inputs, the open input circuit condition is shown when the input signal is lower than the minimum range value minus 4 % of the input span.

7.3 ERRORS

Diagnostics are made at instrument switch-on and during normal mode of operation.

If a fault condition (error) is detected, the display will show the message "E" followed by the relative error code.

The following is a list of possible errors in numerical order.

Also causes, instrument output conditions and possible remedies are briefly described.

Same errors reset the instrument; if the error persist, send back the instrument to your supplier

7.4 ERROR DESCRIPTIONS

E001

The alarm threshold value are incompatible with the actual readout range or their values in memory are incorrect.
It may appear at instrument switching on in operative mode.
The instrument does not start to operate.
Push contemporarily ▲ and ▼ pushbutton and force the threshold values at the initial scale value.
Set the desired threshold values.

E038

EAROM memory reading error.
It may appear at instrument switching on in operative mode.
The instrument does not start to operate.
The instrument remakes this check every 2 seconds.
If this error persists, send back the instrument to your supplier.

E039

EAROM memory writing error during operative mode.
It may appear during operative mode.
This error message will be deleted automatically after 13 seconds.
The new values will be enabled but they will be lost at instrument switch-off.
Send back the instrument to your supplier.

E101

Incorrect configuration data in EAROM memory.
It may appear at instrument switching on in operative mode.
The instrument does not start to operate.
It remakes this check every 2 seconds.
If this error persists, remake the configuration procedure.

E102

Inconsistent configuration parameters.
It may appear at instrument switching on in operative mode.
The instrument does not start to operate.
It remakes this check every 2 seconds.
If this error persists, remake the configuration procedure.

E138

EAROM reading error during configuration procedure.
It may appear during configuration procedure.
Push F pushbutton and restart the configuration procedure.
If this error persists, send back the instrument to your supplier.

E139

EAROM writing error during configuration procedure.
It may appear during configuration procedure.
Push F pushbutton and restart the configuration procedure.
If this error persists, send back the instrument to your supplier.

E201

Incorrect calibration data in EARAM memory.
It may appear at instrument switching on in operative mode.
The instrument does not start to operate.
It remakes this check every 2 seconds.
If this error persists, remake the calibration procedure.

E211/E212

Autozero errors during calibration procedure.
The instrument measure an internal autozero value too negative (E211) or too positive (E212).
It may appear during calibration procedure.
The instrument will not operate and after 6 seconds it will return to the beginning of the calibration procedure.
If this error persists, send back the instrument to your supplier.

E213

Too small input span.
It may appear during calibration procedure when the instrument checks the input calibration and detects an input span less than 450 μ A for current input or 110 mV for 5 V or 220 mV for 10 V or 1300 μ V for TC and mV input or 13 Ω for RTD input
Push F pushbutton and remake the calibration procedure.
If this error persists, send back the instrument to your supplier.

E214/E215

Could junction calibration errors.
The instrument measures a compensation temperature less than -20 °C (E214) or higher than +70 °C (E215).
It may appear during calibration procedure.
Push F pushbutton and remake the calibration procedure.
If this error persists, send back the instrument to your supplier.

E216

Out of range during calibration.
The instrument detects an out of range signal or an open circuit condition during input calibration.
The instrument shows the error message for 6 seconds then it will return to the calibration point where the error was found.
The new calibration of this parameter will be lost, verify the input signal and redo the calibration procedure correctly.

E217

The instrument detects a too big difference between could junction measurement and calibration set during could junction calibration.
The instrument shows the error message for 6 seconds then it will return to the calibration point where the error was found.
The new calibration of this parameter will be lost.
Verify the input signal and redo the calibration procedure correctly.

E218

Too big initial scale value or negative full scale value.
It may appear during input calibration when the instrument check the input calibration and detects an initial scale value higher than 14,5 mA for current input or 3.6 V for 5 V input or 7.2 V for 10 V input or 44 mV for TC and mV input or 440 Ω for RTD input or a negative full scale value.

The instrument shows the error message for 6 seconds then it will return at the calibration point where the error was found.

The new calibration of this parameter will be lost, verify the input signal and redo the calibration procedure correctly.

E238

EAROM reading error during calibration procedure.
Push F pushbutton and restart the calibration procedure.
If this error persists, send back the instrument to your supplier.

E239

EAROM writing error during calibration procedure.
Push F pushbutton and restart the calibration procedure.
If this error persists, send back the instrument to your supplier.

E311/E312

Autozero errors.
The instrument measures an internal autozero value too negative (E311) or too positive (E312).
It may appear during the operative mode.
The instrument will not operate and will repeat this check 13 seconds.
If this error persists, send back the instrument to your supplier.

E313

Too small input span.
It may appear during operative mode when the instrument detect an input span less than 450 μ A for current input or 110 mV for 5 V or 220 mV for 10 V or 1300 μ V for TC input or 13 Ω for RTD input.
Remake the calibration procedure.
If this error persists, send back the instrument to your supplier.

E314/E315

Could junction measurement errors.
The instrument measure a compensation temperature less than -20 $^{\circ}$ C (E314) or higher than +70 $^{\circ}$ C (E315).
It may appear during the operative mode.
Check the temperature and, if necessary, remake the calibration procedure.
If this error persists, send back the instrument to your supplier.

**E401**

The instrument detects the incorrect access to a protected memory area (this error may be generated by a big noise only).
After 2 seconds the instrument restarts automatically.
Verify configuration and calibration parameters.

E402

This error may appear switch-on the instrument only.
The calibration and configuration parameters are not protected.
Go to configuration mode, select a parameter and push F pushbutton.
Return in operative mode.
If this error persists, send back the instrument to your supplier.

E403

The instrument detects a dip switch position changement or an incorrect access to the program memory area (this error may be generated by a big noise only).
After 2 seconds the instrument restarts automatically.
Verify configuration and calibration parameters.







DPS

Serial No.....

Tag No.....

INPUT LINEARIZATION

Measure

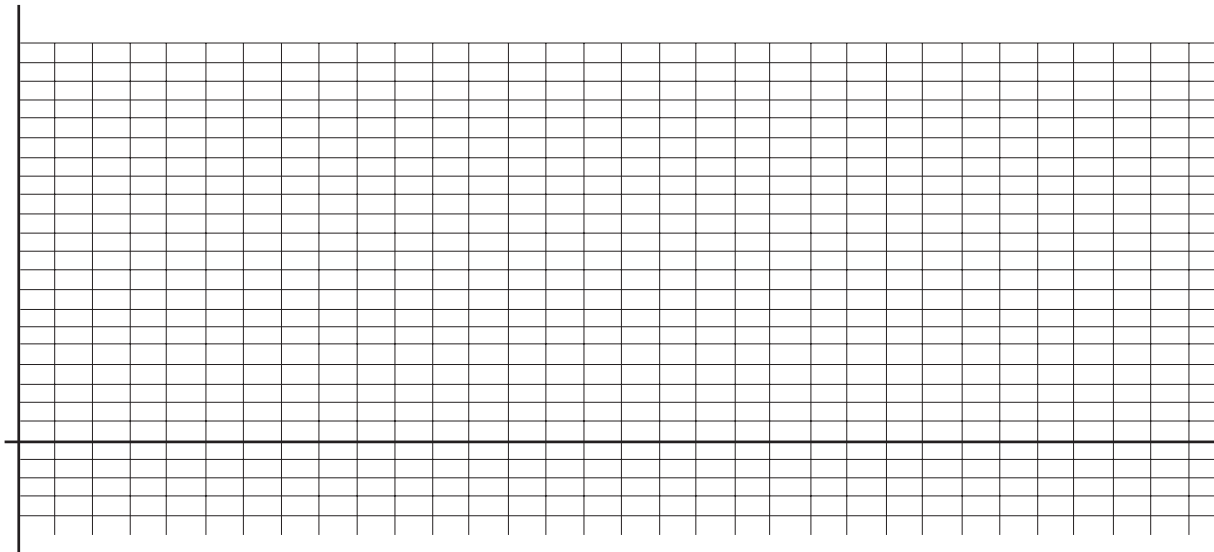

READOUT



DPS

Serial No..... Tag No.....

INPUT LINEARIZATION BY BREAKPOINTS

breakpoint	Input in %	Input in eng.	Readout	NOTES
0	0	units		Initial input rang value
1				
2				
3				
4				
5				
6				
7				
8				
9				
10				



Ero Electronic S.r.l.
Via E. Mattei, 21
28100 Novara
Italy
Tel. +39 0321481111
Fax +39 0321481112
eroelectronic@ero.eurotherm.co.uk

BENELUX
ERO Electronic Benelux SA/NV
Rue Val Notre Dame 384
MOHA 4520 (WANZE)
Tel. 085-274080
Fax 085-274081
ero.electronic@skynet.be

BRASIL
ERO ELECTRONIC DO BRASIL Industria e
Comercio Ltda.
Rua Garibaldi, 659 - Conj. 202
90035-050 PORTO ALEGRE
Tel. 051-2214888
Fax 051-2214734
erobr@nutecnet.com.br

CHINA
TIANJIN VEGA COMPANY Ltd
(TAIF)
Hebei District
300232 TIANJIN
Tel. 022-26273296
Fax 022-26273297

FRANCE
ERO Electronic SARL
Zac du Chêne
34, Rue du 35ème Régiment d'Aviation
69673 BRONCEDEX
Tel. 0478267979
Fax 0478267800

GERMANY
ERO Electronic GmbH
Ottostrasse 1
65549 LIMBURG A.D. LAHN
Tel. 06431-95680
Fax 06431-57493

NETHERLAND
ERO Electronic Nederland
Ganieelan 4
2404 CH Alphen a/d Rijn
Tel. 0172-420400
Fax. 0172-420395
sales@eroelectronic.nl

SOUTH AFRICA
ERO Electronic S.A. Pty Ltd
Airgro House
1343, Spokeshave Avenue
Stormill Ext 2 ROODEPOORT
Tel. 011-4742278/9
Tel. 011-4749404
Fax 011-4749404
P.O. Box 43112
Industria 2042
ero-sa@kingsley.co.za

SPAIN
ERO ELECTRONIC IBERICA
Calle La granja, 74
Pol. Ind. Alcobendas
MADRID
Tel. 091-6618194
Fax. 091-6619093

U.K.
ERO U.K.
Unit 1, Cygnet Trading Estate
Faraday Close
Durrington, Worthing
WEST SUSSEX BN13 3RQ
Tel. 01903-693322
Fax. 01903-693377

U.S.A.
AMERICAN ERO Electronic Corp
BARRINGTON, ILL. 60010
Tel. 0847-382-0881
Fax 0847-382-0240
U.S.A.
BARBER COLMAN
Industrial Instruments Div.
P.O. BOX 2940
Loves Park, IL - 31132 - 2940
Tel. 0815-637-3000
Fax 0815-637-5341
jgsearle@ad.com