

---

**7000 RANGE**

**7300S**  
**SMART CONTROLLER**

**THREE-PHASE**  
**SOLID STATE CONTACTOR**

**User Manual**

© Copyright Eurotherm Limited 2003

All rights reserved. All reproduction or transmission in any form whatsoever and using any procedure (electronic or mechanical, including photocopying and recording) without written permission from Eurotherm is strictly prohibited.

# COMMISSIONING FLOWCHART

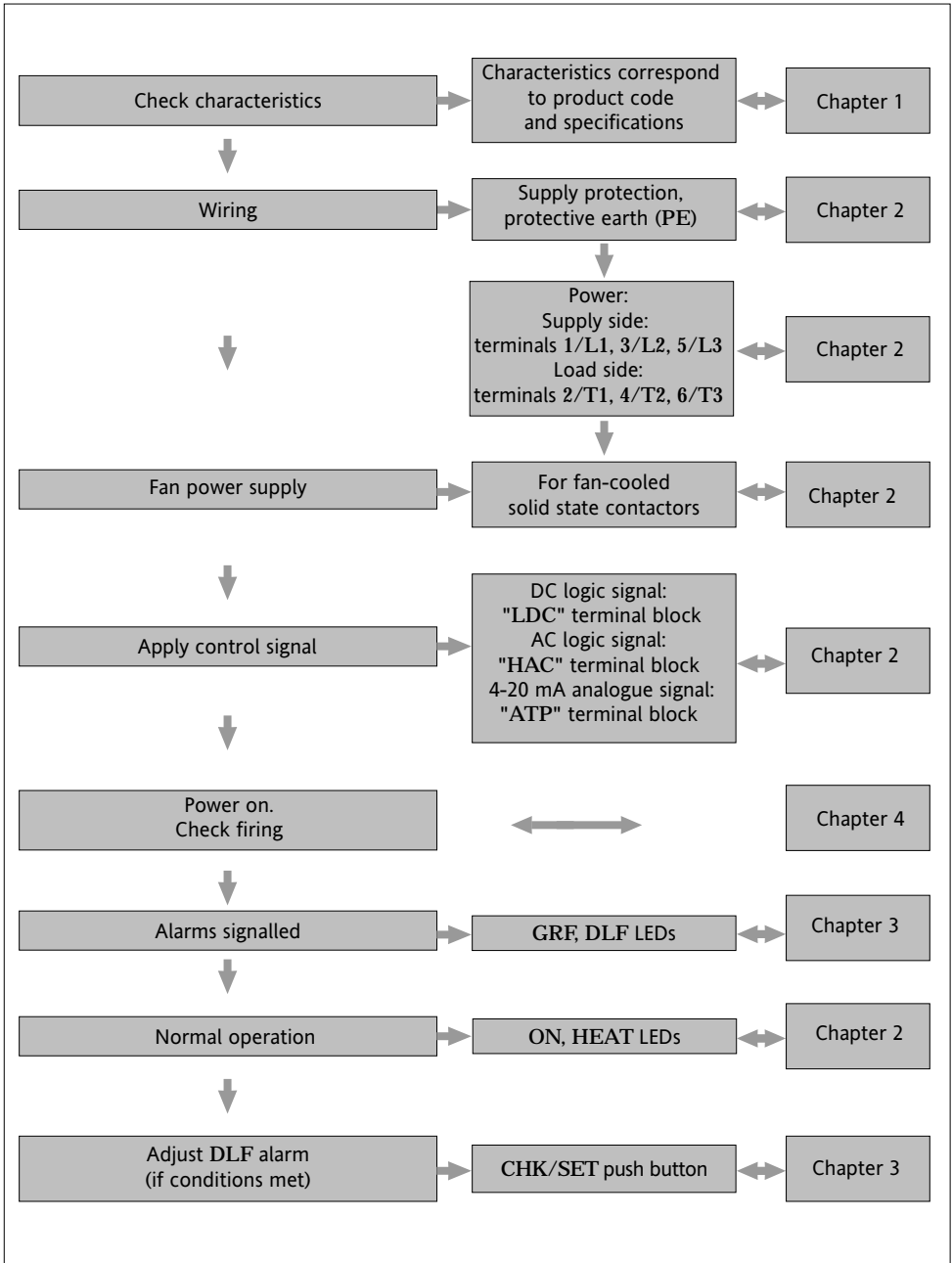

## CONTENTS

|  | Page |
|--|------|
| Commissioning flowchart . . . . .                                  | .ii  |
| European directives and applicable standards . . . . .             | .iv  |
| <b>Chapter 1</b> Identification of solid state contactor . . . . . | .1-1 |
| <b>Chapter 2</b> Installation . . . . .                            | .2-1 |
| <b>Chapter 3</b> Alarms . . . . .                                  | .3-1 |
| <b>Chapter 4</b> Maintenance . . . . .                             | .4-1 |
| <b>Eurotherm Limited</b> . . . . .                                 | .5-1 |

## PURPOSE OF MANUAL

This manual (Issue **2.1**) describes the Basic Version and all Options for 7300S series solid state contactors with current ratings **up to 160 A**.

# EUROPEAN DIRECTIVES AND APPLICABLE STANDARDS

## COMPLIANCE WITH PRODUCT STANDARD

7300S products comply with the terms of product standard **EN 60947-4-3** 'Contactors and motor-starters - AC semiconductor controllers and contactors for non-motor loads'.

## CE LABELLING

7300S products, installed and operated in accordance with their user manual, bear CE labelling on the basis of compliance with the essential requirements of :

- the **European Low Voltage Directive 73/23** EEC dated 19 February 1973 modified by 93/68 EEC dated 22 July 1993
- the **Electromagnetic Compatibility Directive 89/336/EEC** dated 3 May 1989 modified by 92/31/EEC dated 28 April 1992 and 93/68/EEC dated 22 July 1993.

## SAFETY

The units have IP20 protection rating as defined by standard IEC 60529.

External wiring must comply with standards IEC 60364-4-43 and IEC 60943.

Copper cables and conductors must be used, rated to a temperature of 75°C (167°F).

## ELECTROMAGNETIC COMPATIBILITY (EMC) TEST STANDARDS

7300S products installed and used in accordance with the user manual, are designed for an industrial environment and not a commercial or light industrial premises and must not be used in the home.

## IMMUNITY

The EMC immunity test standards required by product standard EN 60947-4-3 are given in the table following :

| Test type                                       | Minimum level  | EMC test standard |
|---|--|-------------------|
| Electrostatic discharge                         | 4 kV on contact; 8 kV in air   | EN 61000-4-2      |
| Radiated, radio frequency electromagnetic field | 10 V/m 80 MHz $\leq f \leq$ 1 GHz ;<br>80% modulation 1 kHz sinusoid | EN 61000-4-3      |
| Electrical fast transient / burst               | 2 kV / 5 kHz   | EN 61000-4-4      |
| Electrical Surge                                | 4 kV line to earth<br>2 kV line to line                              | EN 61000-4-5      |
| Conducted disturbances                          | 140 dB $\mu$ V; 150 kHz $\leq f \leq$ 80 MHz                         | EN 61000-4-6      |
| Voltage dips and short interruptions            | 5 s interruptions  | EN 61000-4-11     |

Table 1 EMC immunity standards compliance

## EMISSIONS

The EMC emissions test standards required by product standard EN 60947-4-3 are given in the table following :

| <b>Emission type</b>           | <b>Firing mode</b> | <b>EMC test standard</b> |
|--------------------------------|--------------------|--------------------------|
| Radiated at radio frequencies  | All firing modes   | CISPR 11 Class A         |
| Conducted at radio frequencies | All firing modes   | CISPR 11 Class A Group 2 |

Table 2 EMC emissions standards compliance

## EMC GUIDE

To help you deal with installation-dependent electromagnetic interference effects, Eurotherm provides an 'Electromagnetic compatibility' installation guide (ref. HA 025464) which sets out best current practice regarding EMC.

## DECLARATION OF CONFORMITY

A CE declaration of conformity is available on request.



# Chapter 1

## 1. IDENTIFICATION OF SOLID STATE CONTACTOR UNITS

| Contents                                   | Page        |
|--|-------------|
| <b>1.1. General presentation</b> .....     | <b>1-2</b>  |
| <b>1.2. Technical specifications</b> ..... | <b>1-5</b>  |
| <b>1.2.1. Use</b> .....                    | <b>1.5</b>  |
| <b>1.2.2. Power</b> .....                  | <b>1.5</b>  |
| <b>1.2.3. Load</b> .....                   | <b>1.5</b>  |
| <b>1.2.4. Signalling</b> .....             | <b>1.5</b>  |
| <b>1.2.5. Firing Modes</b> .....           | <b>1.6</b>  |
| <b>1.2.6. Inputs</b> .....                 | <b>1.6</b>  |
| <b>1.2.7. Control</b> .....                | <b>1.6</b>  |
| <b>1.2.8. Alarms</b> .....                 | <b>1.7</b>  |
| <b>1.2.9. Protection</b> .....             | <b>1.7</b>  |
| <b>1.2.10. Environment</b> .....           | <b>1.8</b>  |
| <b>1.2.11. Dimension</b> .....             | <b>1.8</b>  |
| <b>1.2.12. Mounting</b> .....              | <b>1.8</b>  |
| <b>1.2.13. Digital Communication</b> ..... | <b>1.8</b>  |
| <b>1.3. Coding</b> .....                   | <b>1-10</b> |

# 1. Chapter 1 IDENTIFICATION

## 1.1 GENERAL PRESENTATION

**7300S** series solid state contactors control the **electrical power** to three-phase industrial loads such as low temperature coefficient and short wave infrared elements.

Standard ratings in the series range from **16 A** to **160 A**, at voltages from **200 V** to **500 V**.

**7300S** series solid state contactors comprise three channels, **controlled by thyristors**. Depending on the type of control signal and the type of input specified, **2** operating modes are available: logic ('on/off') or modulation ('Burst mode').

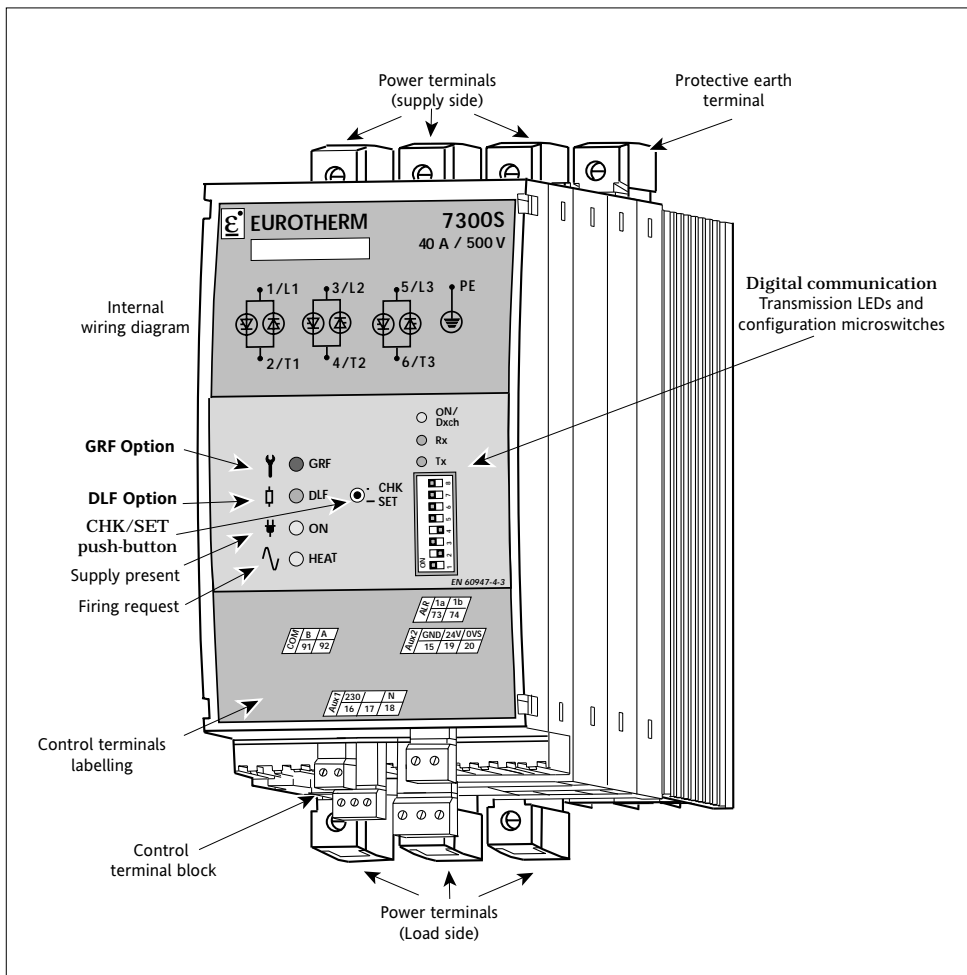

Figure 1-1 General view of 7300S with digital communication control - ratings from 16 A to 40A

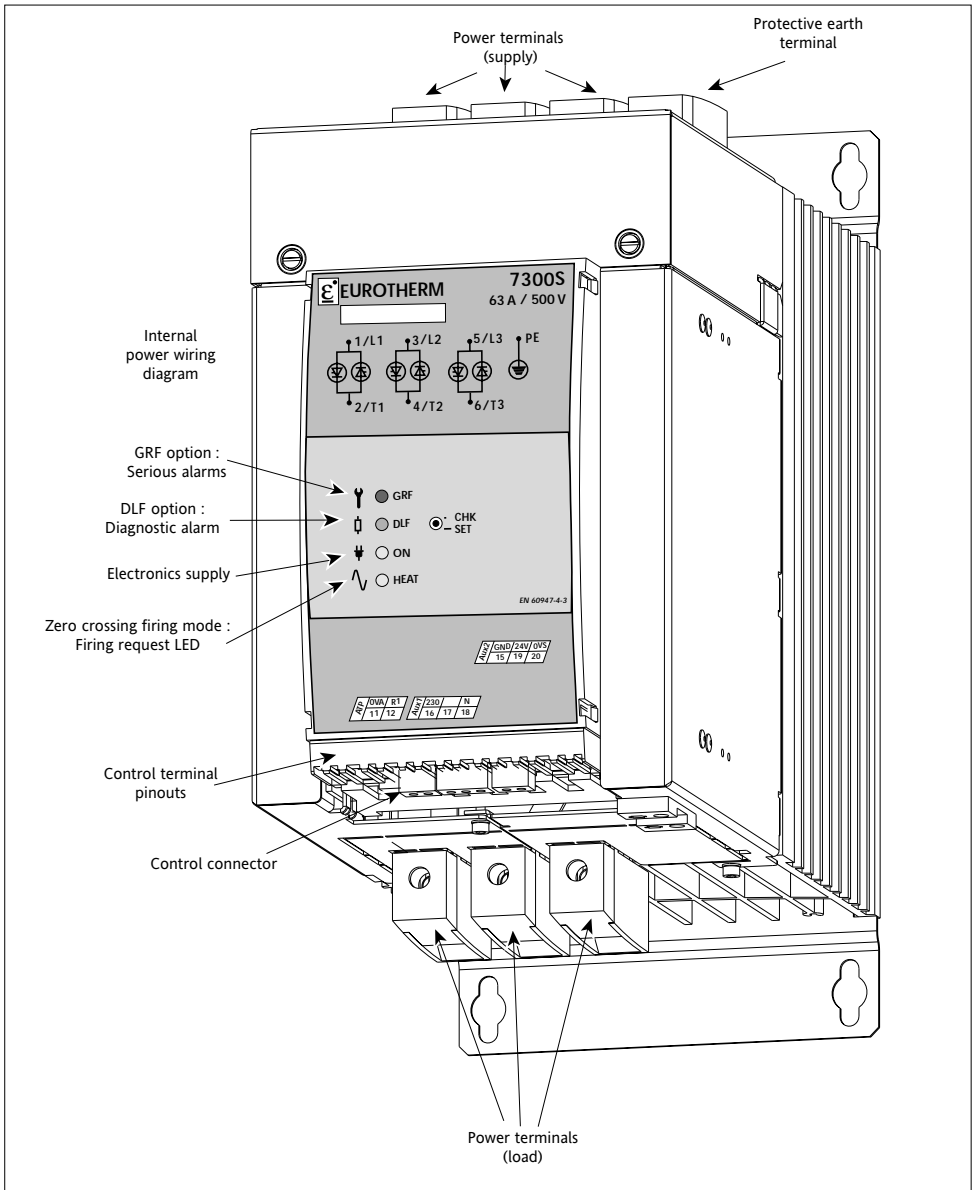

Figure 1-2 General view of 7300S with analogue control - ratings from 63 A to 100 A

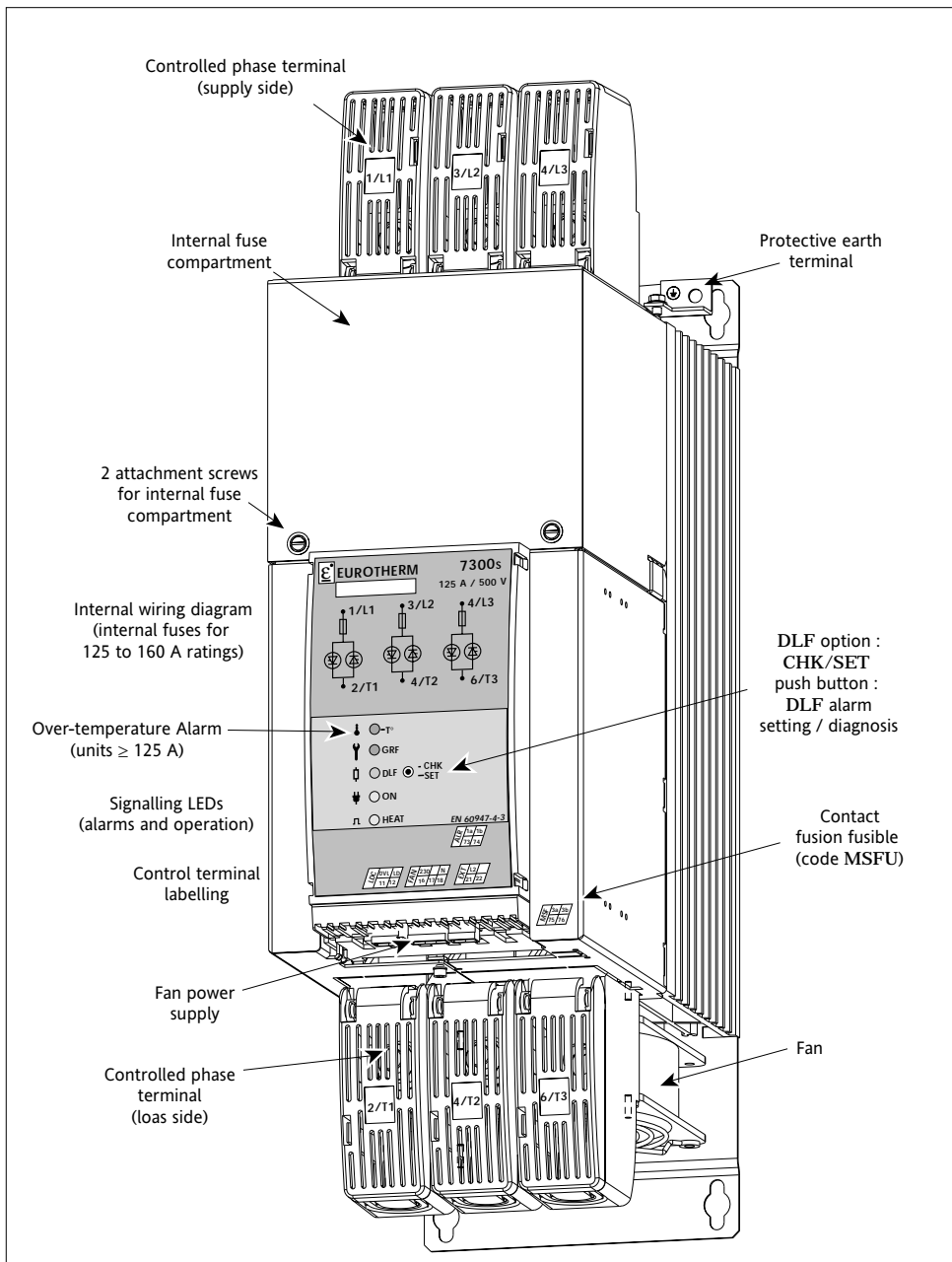

Figure 1-3 General view of 7300S with analogue control - ratings  $\geq 125$  A

## 1.2. TECHNICAL SPECIFICATIONS

### 1.2.1. USE

In accordance with product standard EN 60947-4-3:

Units for uninterrupted service :

1. Semiconductor contactor (DOL) variant 5 :  
logic input signal : DC (LDC input) or AC (HAC input).
2. Thyristor unit variant 4 :  
4-20 mA analogue input signal : ATP input or digital communication option.

Configuration on order.

### 1.2.2. POWER

Nominal current per phase

16 A to 160 A (defined at 45°C) depending on product code  
The unit can be used up to 60°C ambient temperature, following derating curves. Please consult Eurotherm.

Nominal line to line voltage

200 V to 500 V depending on product code (+10% and -15%).

Frequency

Use from 47 to 63 Hz (automatic matching)

Dissipated power

Approx : 1.3 W (typical) - 2 W max per amp and per phase (with fuses).

Cooling

Ratings  $\leq$  100 A: natural convection

Ratings  $\geq$  125A: fan (115 V or 230 V external supply), consumption 10 VA.

### 1.2.3. LOAD

Categories of use

Three-phase Industrial Load.

The categories of use applicable for each unit are indicated on the identification label

- AC-51 Non-inductive or low inductance loads, furnace resistances  
(Resistive load with low temperature coefficient).
- AC-55b Switching of incandescent lamps, short wave infrared elements (SWIR), for  $\leq$  100 A units.

Connections

Independent of order of phase rotation

Load configuration

- Star with neutral (4 wires)
- Star without neutral (3 wires)
- Closed delta (3 wires)
- Open delta (6 wires).

### 1.2.4.SIGNALLING

#### Basic version

Supply present

Green 'ON' LED.

Thyristor firing request

Green 'HEAT' LED.

#### With options

Alarms

Red and orange LEDs, alarm relay contact.

### 1.2.5. FIRING MODES

#### Thyristor switching

At thyristor zero voltage crossing.

##### *'Logic' mode*

DC signal applied to LDC input (Low Direct Current).  
AC signal applied to HAC input (High Alternating Current).

##### *'Burst' mode*

Supply voltage modulated by the 4-20 mA analogue signal applied to the ATP input (Analogue to Time Proportional).  
Firing base time: 0.3 s (approx. 15 cycles at 50 Hz).

- with 'Digital Communication' option  
base modulation time: from 1 cycle ('Single-cycle' mode)  
(or 1 half-cycle in 'Advanced single-cycle' mode)  
to 255 cycles.

### 1.2.6. INPUTS

#### Power Supply

Self-powered electronics.

##### *'Logic' firing:*

- DC signal  
(LDC input)

Conducting from 4.5 Vdc to 32 Vdc max, current  $\geq 9$  mA.  
Off  $< 1.5$  V or  $< 0.1$  mA. Response time  $\leq 10$  ms.  
If the unit has the DLF option, ant that you want to drive it using a REMIO output or i7000, please contact the Eurotherm's application services

- AC signal  
(HAC input)

Conducting from 85 to 253 Vac max. Impedance  $\approx 7$  k $\Omega$  at 50 Hz.  
Off  $< 10$  Vac. Response time  $\leq 60$  ms.  
(If an RC snubber contact protection circuit or control optotriac is used, the maximum capacitor value is 22 nF for 240 Vac).

- With DLF option :

- According to the control signal, one of the two following criteria must be respected:
  - $T_{\text{conduction min}} = T_{\text{non-conduction min}} \geq 0.3$  second
  - $T_{\text{modulation}} \geq 4$  seconds

##### *'Burst mode' firing:*

- Analogue signal  
(ATP input)

4 - 20 mA (10 Vdc max).  
Modulation depending on signal.  
Firing base time: 0.4 s @ 50 % and 50 Hz.

- Digital communication  
(MOP option)

Digital signals, Modbus® protocol

### 1.2.7. CONTROL - ATP input only

#### Control type

Open loop

#### Linearity and Stability

Better than  $\pm 2\%$  of full scale.

## 1.2.8. ALARMS (Options)

### GRF option

Serious alarms

Total load failure (TLF) and thyristor short circuit (THSC) detection.

Signalling

When a serious alarm is detected:

- the red 'GRF' LED is lit
- the alarm relay contact is activated.

### DLF option

Diagnostic alarm

Partial load failure detection and diagnosis.

Signalling

If a partial load failure (PLF fault) is detected:

- the orange 'DLF' LED is lit
- the alarm relay contact is activated.

Settings

The front panel push button is used for:

- monitoring and diagnosis
- adjusting and resetting the alarm.

Sensitivity

Detects the failure of at least :

**1 element out of 4** in **3S, 4S, 6D** configuration  
**1 element out of 3** in **3D** configuration

Extension

The DLF option includes serious alarm monitoring (GRF option included).

PLF fault detection for SWIR is only available with IHC or FC1 conduction modes. (with MOP option or controlling using a REMIO, only in 4S or 6D configurations)

### Over-temperature alarm

For all fan-cooled units ( $\geq 125$  A), the unit cuts out if the temperature threshold is exceeded, whether or not options are fitted.

Signalling

If an over-temperature alarm is detected:

- the red 'T°' LED is lit
- the alarm relay contact is activated

provided one of the alarm options is selected.

### Alarm relay

Available with one of the Alarm options.

The relay contact (0.25 A/230 Vac or 30 Vdc) is either open on alarm or closed on alarm depending on the product code.

## 1.2.9. PROTECTION

Short circuits

Type 1 (high-speed fuses).

co-ordination type

IP20 without adding additional protection.

Electrical protection

Varistors and RC snubbers.

Thyristors

High-speed fuses:

- ratings  $\leq 100$  A: external (selected in product code)
- ratings  $\geq 125$  A: internal.

No fuse for short wave infrared elements.

Replacement fuses

See chapter 4.

### 1.2.10. ENVIRONMENT

Use 0 to 45°C at nominal current, at maximum altitude of 1000 m.  
 Storage -10°C to 70°C.  
 Isolation voltage Assigned isolation voltage  $V_i = 500 V_{rms}$   
 Pollution Degree 2 acceptable (defined by IEC 60664).  
 Humidity RH 5% to 95%, non-condensing, non-streaming.  
 Over-voltage Over-voltage category II (as defined by IEC 60664)  
 $V_{imp} = 4 \text{ kV}$ .

### 1.2.11. DIMENSIONS

| Ratings        | Height | Width  | Depth (mm) |                       |                        |            |
|----------------|--------|--------|------------|-----------------------|------------------------|------------|
|                |        |        | Basic      | GRF only or Comm only | GRF + Comm or DLF only | DLF + Comm |
| 16 A to 40 A   | 220 mm | 96 mm  | 164        | 189                   | 214                    | 239        |
| 63 A to 100 A  | 305 mm | 144 mm | 295        | 295                   | 372                    | 372        |
| 125 A to 160 A | 498 mm | 144 mm | 295        | 295                   | 372                    | 372        |

Table 1-1 Units dimensions according to the ratings and the options chosen

### 1.2.12. MOUNTING

Attachment Attachment plate fixed to unit:  
 • on symmetrical EN50022 DIN rail or  
 • bulkhead mounting  
 (for ratings  $\geq 63 \text{ A}$ : bulkhead mounting only).

### 1.2.13. DIGITAL COMMUNICATION

Availability The digital communication option is exclusive with:  
 • control using the logic or analogue input signal.

Protocol Modbus® RTU.

Compliance Communication complies with the specifications given in 'GOULD MODICON Protocol Reference Guide PI-MBUS-300 rev J'.

Power supply 24 Vac ( $\pm 20\%$ ), 47 to 63 Hz or  
 24 Vdc ( $\pm 20\%$ ) non-polarised.  
 Typical consumption 1.5 VA  
 Protection: external 2 A fuse.  
 External wiring should comply with standard IEC 60364.

Transmission Standard RS485, 2 wires.  
 Speed: 9600 or 19200 baud.  
 Selected by switch on front panel. The speed is factory set to correspond to the selected product code.

---

|                               |   |
|-------------------------------|---|
| Termination                   | The communication bus must have termination resistors fitted at each end: <ul style="list-style-type: none"><li>• one line impedance matching resistor.</li><li>• two RS485 bus polarisation resistors.</li></ul>                                   |
| Address                       | Adjustable between 1 and 127 using front panel switches only. The physical address is factory configured to 32 by default.  |
| Diagnostic                    | <ul style="list-style-type: none"><li>• Green LED on front panel indicates power presence, waiting for frames, communication established.</li><li>• Two orange LEDs show the status of the communication bus (transmission or reception).</li></ul> |
| Control                       | Supply voltage compensation operates for variations up to $\pm 20\%$ of nominal voltage, using $V^2$ control  |
| Parameters and operating mode | Read and write by digital communication<br>(see Digital communication manual, part No. HA176664ENG).  |
| Firing base time              | Configurable over communication link (@ 50% of power): <ul style="list-style-type: none"><li>• 1 or 255 cycles ('Burst mode').</li></ul> The default base time is factory configured to 16 cycles.  |

# CODING

**7300S Current / Voltage / Fan / Configuration / Fuses / Input / Language / Options**

| 1. Nominal current per phase | Code        |
|------------------------------|-------------|
| 16 amps                      | <b>16A</b>  |
| 25 amps                      | <b>25A</b>  |
| 40 amps                      | <b>40A</b>  |
| 63 amps                      | <b>63A</b>  |
| 80 amps                      | <b>80A</b>  |
| 100 amps                     | <b>100A</b> |
| 125 amps                     | <b>125A</b> |
| 160 amps                     | <b>160A</b> |

| 2. Nominal line-to-line voltage | Code        |
|---------------------------------|-------------|
| 200 volts to 230 volts          | <b>230V</b> |
| 277 volts                       | <b>277V</b> |
| 400 volts to 500 volts          | <b>500V</b> |

| 3. Fan           | Code        |
|------------------|-------------|
| ≤ 100 A : no fan | <b>XXXX</b> |
| ≥ 125 A: fan     |             |
| • 115 V supply   | <b>115V</b> |
| • 230 V supply   | <b>230V</b> |

| 4. Load configuration | Code      |
|-----------------------|-----------|
| Star without neutral  | <b>3S</b> |
| Star with neutral     | <b>4S</b> |
| Closed delta          | <b>3D</b> |
| Open delta            | <b>6D</b> |

| 5. High-speed fuses                                   | Code                 |
|---|----------------------|
| Thyristor protection fuses only                       |                      |
| • without microswitch                                 | <b>FUSE<br/>MSFU</b> |
| • with microswitch                                    |                      |
| ( ≤ 100 A: external fuses<br>≥ 125 A: internal fuses) |                      |
| No fuses or control of Short wave infrared elements   | <b>NONE</b>          |

| 6. Input                             | Code       |
|--------------------------------------|------------|
| 'On/off' firing                      |            |
| DC logic signal<br>4.5 Vdc to 32 Vdc | <b>LDC</b> |
| AC logic signal<br>85 Vac to 253 Vac |            |
| 'Burst mode' firing                  |            |
| Analogue DC signal<br>4 mA to 20 mA  | <b>ATP</b> |

| 7. Manual language | Code       |
|--------------------|------------|
| French             | <b>FRA</b> |
| English            | <b>ENG</b> |
| German             | <b>GER</b> |

| 8. Selected options  | Code        |
|----------------------|-------------|
| No options           |             |
| <i>End of code</i>   | <b>NONE</b> |
| Selection of options | <b>YES</b>  |

|   |
|---|
| <b>Alarm option:</b> <b>Communication option: Certificate</b><br><b>/ Alarm / Load / Contact / Protocol / Transmission / option / Warranty</b><br><b>selected    Type            Type</b> |
|---|

| 9. Alarm option<br><i>(Options selected: YES)</i>   | Code                         |
|---|------------------------------|
| Serious Alarms:<br>Thyristor short-circuit,<br>Total Load failure (over-<br>temperature for ratings $\geq 125$ A)<br>Partial load failure<br>and Serious alarms | <b>GRF</b><br><br><b>DLF</b> |
| No alarms   | <b>NONE</b>                  |

| 10. Load type  | Code                       |
|--|----------------------------|
| <i>For DLF option:</i> <ul style="list-style-type: none"> <li>• Resistive load with low temperature coefficient</li> <li>• Short wave infrared elements</li> </ul> | <b>LTCL</b><br><b>SWIR</b> |
| <i>Without DLF option</i>  | <b>XXXX</b>                |

| 11. Alarm relay contact   | Code                   |
|---|------------------------|
| <i>GRF or DLF option:</i><br>Alarm relay contact <ul style="list-style-type: none"> <li>• Closed on alarm</li> <li>• Open on alarm</li> </ul> | <b>NC</b><br><b>NO</b> |
| <i>Without alarm option</i>   | <b>XX</b>              |

| 12. Communication option                                    | Code        |
|---|-------------|
| Digital communication<br>Communication protocol:<br>Modbus® | <b>MOP</b>  |
| No communication  | <b>NONE</b> |

| 13. Transmission speed<br><i>(Comm. option other than NONE)</i> | Code                      |
|---|---------------------------|
| Transmission speed:<br>9.6 kbaud<br>19.2 kbaud                  | <b>9K6</b><br><b>19K2</b> |
| No communication  | <b>XXXX</b>               |

| 14. Certification option                          | Code        |
|---|-------------|
| Without Certificate of<br>'Compliance with Order' | <b>NONE</b> |
| With certificate of<br>'Compliance with Order'    | <b>CFMC</b> |

| 15. Warranty Extension                | Code        |
|---------------------------------------|-------------|
| Without warranty extension            | <b>NONE</b> |
| With warranty extension<br>to 5 years | <b>CFMC</b> |



## Chapter 2

### INSTALLATION

| Contents   | Page |
|--|------|
| <b>2.1. Safety during installation</b> .....                   | 2-2  |
| <b>2.2. Mounting</b> .....                                     | 2-3  |
| <b>2.2.1. Types of mounting</b> .....                          | 2-3  |
| <b>2.2.2. Attachment plates</b> .....                          | 2-3  |
| <b>2.2.3. Mounting on DIN rails</b> .....                      | 2-3  |
| <b>2.2.4. Bulkhead mounting</b> .....                          | 2-4  |
| <b>2.3. Wiring</b> .....                                       | 2-5  |
| <b>2.3.1. General connection diagram</b> .....                 | 2-5  |
| <b>2.3.2. Power connections</b> .....                          | 2-7  |
| <b>2.3.2.1. General</b> .....                                  | 2-7  |
| <b>2.3.2.2. Power connection details</b> .....                 | 2-7  |
| <b>2.3.2.3. Three-phase load wiring schemes</b> .....          | 2-7  |
| <b>2.3.3. Control terminal blocks</b> .....                    | 2-9  |
| <b>2.3.3.1. Control signal</b> .....                           | 2-9  |
| <b>2.3.3.2. Alarm relay contact (option)</b> .....             | 2-9  |
| <b>2.3.3.3. Connecting the reference neutral voltage</b> ..... | 2-10 |
| <b>2.3.3.4. Fan power supply</b> .....                         | 2-10 |
| <b>2.3.3.5. Connecting the digital communication</b> .....     | 2-11 |

## 2. Chapter 2 INSTALLATION

### 2.1. SAFETY DURING INSTALLATION (MOUNTING AND WIRING)

#### Danger!



- 7300S solid state contactors must be installed and wired by qualified staff authorised to work on low voltage industrial electrical facilities.

- Units must be installed in a fan-cooled cabinet, to ensure that condensation and pollution are excluded, with a class of at least 2 (according to IEC 60664). We recommend fitting fan-cooled cabinets with a fan failure detection device or a safety cut-out triggered by the internal temperature of the cabinet. Cabinets must be closed and connected to the protective earth according to IEC 60364 or applicable national standards.

#### Important!



- Units must be mounted with the heatsink positioned vertically, and with no obstructions above or below the unit which could reduce or hamper air flow. If several units are fitted in the same cabinet, arrange them such that air from one unit is not drawn in by the unit above. The ambient temperature beneath the unit must not exceed 45°C. Leave a gap of at least 10 mm between adjacent units.

#### Important!



- Nominal currents correspond to use at ambient temperatures of no more than 45°C. Overheating may cause incorrect operation and may even lead to components being damaged.

#### Danger!



- It is the user's responsibility to wire and protect the facility according to best practice and applicable standards.

A suitable device, ensuring that the unit can be electrically isolated from the supply, must be installed upline to enable work to be performed safely.

Conductor cross-sections should comply with IEC 60943.

Only use copper cables and wires rated for use at 75°C.

- Before connecting or disconnecting the unit check that power and control cables and leads are isolated from voltage sources.

The protective earth must be connected before any other connections are made and should be the last cable to be disconnected.

The protective earth connection terminal is marked with the symbol:



#### Important!



- To ensure that 7300S solid state contactors comply with Electromagnetic Compatibility requirements, ensure that the panel or DIN rail to which they are attached is correctly grounded.

The ground connection, designed to ensure **ground continuity**, is not in any way a substitute for the protective earth connection.

- Run low voltage and power cables in separate cable ducts or trays.

## 2.2. MOUNTING

### 2.2.1. TYPES OF MOUNTING

- DIN rail mounting - 16 A to 40 A only
- Bulkhead mounting with screws  $\geq 63$  A.

| DIN rail mounting ( $\leq 40$ A only)            |   | Bulkhead mounting                                |   |
|--|---|--|---|
| <b>Attachment plate</b><br>Two horizontal plates | <b>DIN rail</b><br>Two symmetrical rails EN 50022 | <b>Attachment plate</b><br>Two horizontal plates | <b>Screws</b><br>$4 \times M4$ ( $\leq 40$ A)<br>$4 \times M6$ ( $\geq 63$ A) |

Table 2-1 Attachment details for both mounting types

### 2.2.2. Attachment plates (figures 2-1 to 2-4)

**Two factory-fitted attachment plates** on the rear of the 7300S solid state contactor are used :

- to clip the unit to a DIN rail, or
- to screw the unit to a bulkhead.

Each attachment plate has:

- attachment holes for bulkhead mounting, and
- two fixed hooks and two mobile hooks for clipping to a DIN rail. (the mobile hooks are moved using a catch and spring).

### 2.2.3. Mounting on DIN rails

- fix two symmetric DIN rails (for units rated 16 A to 40 A) in accordance with the unit dimensions and safety recommendations
- bring the unit up against the top rail, engaging the two fixed hooks on the top attachment plate
- push the unit against the rail
- clip the unit onto the bottom rail using the mobile hooks on the bottom attachment plate, ensuring that they are properly engaged.

To **remove** the unit:

- move the mobile hooks downwards by pulling the catch on the bottom attachment plate
- unclip the unit from the rail.

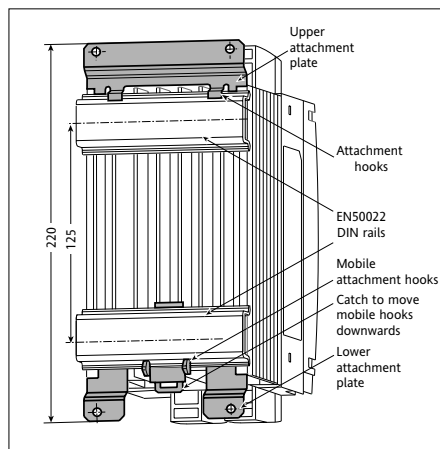

Figure 2-1 Attaching the 7300S to DIN rails

### 2.2.4. Bulkhead mounting

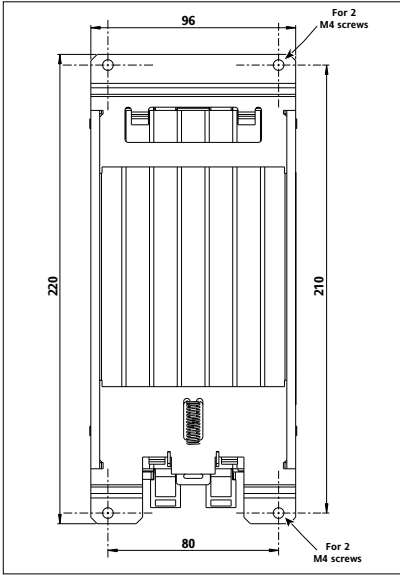

Figure 2-2 Units from 16 A to 40 A

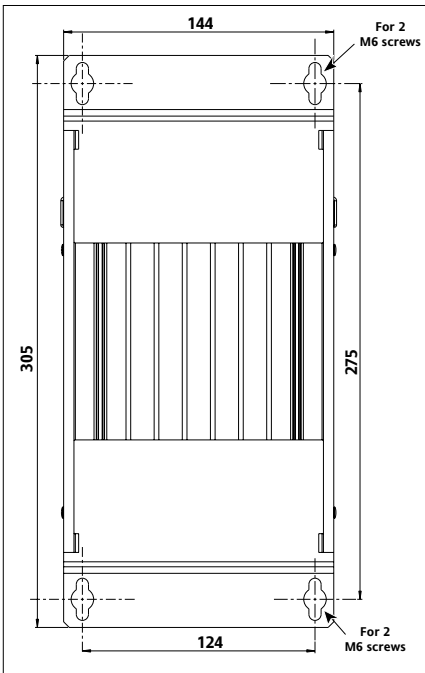

Figure 2-3 Units from 63 A to 100 A

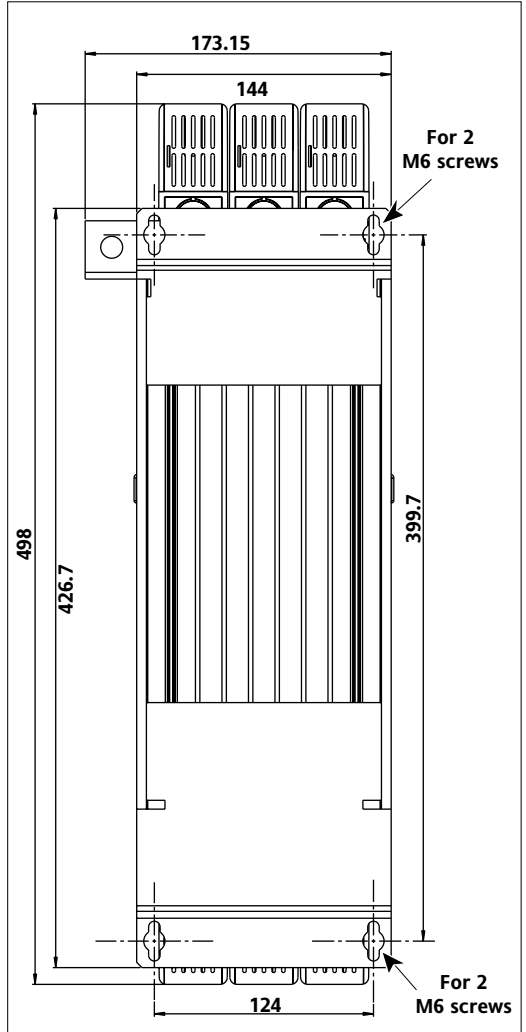

Figure 2-4 Units  $\geq 125$  A

## 2.3. WIRING

### 2.3.1. GENERAL CONNECTION DIAGRAM

The general connection diagram shows the power terminals (independent of the three-phase load configuration) and control connectors.

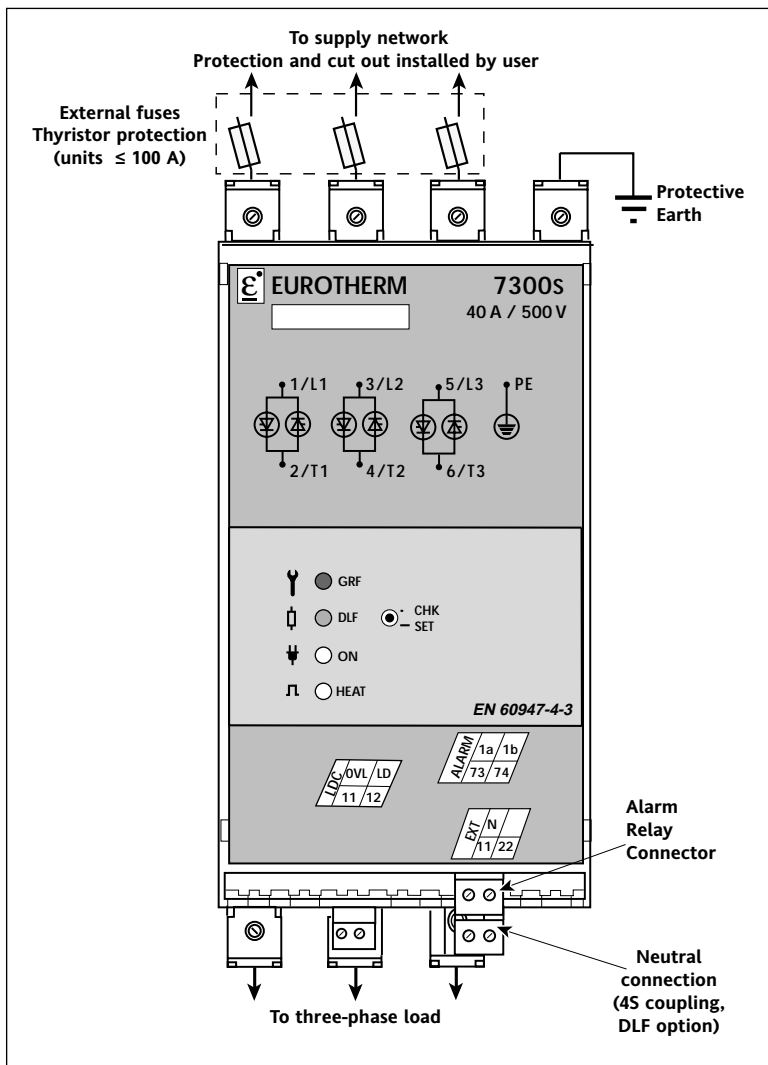

Figure 2-5 General connection diagram for ≤ 100 A units

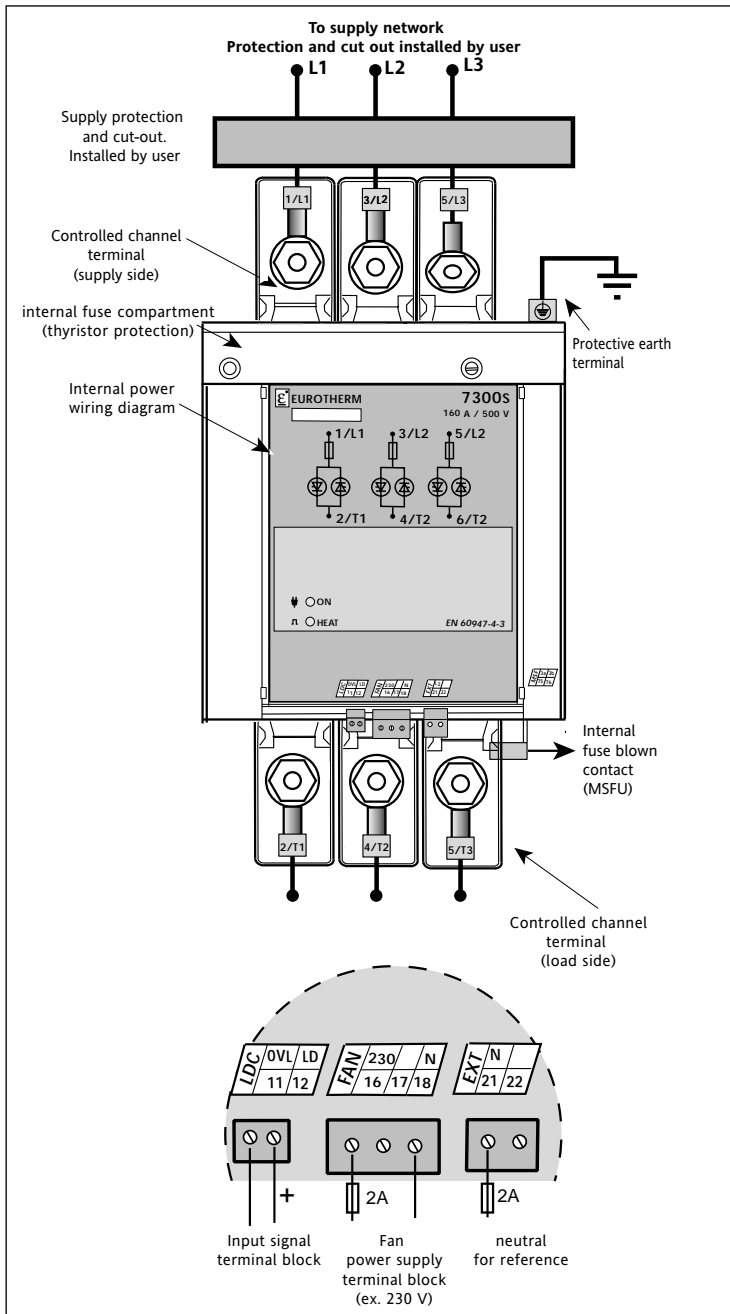

Figure 2-6 General connection diagram for  $\geq 125$  A units

## 2.3.2. POWER CONNECTIONS

### 2.3.2.1. General

7300S solid state contactors comprise three channels controlled by thyristors.

Terminals **1/L1**, **3/L2** and **5/L3** must be wired to the three-phase supply network.

Terminals **2/T1**, **4/T2** and **6/T3** must be wired to the three-phase load.

The protective earth terminal **PE** (marked with the earth symbol) must be wired to the protective earth (see section 'Safety during installation' - page 2-2).

### 2.3.2.2. Power connection details

| Rating A   | Terminal capacity      |         | Torque Nm   | Stripping length mm |
|------------|------------------------|---------|---|---------------------|
|            | mm <sup>2</sup>        | AWG     |   |                     |
| 16 to 25   | 2.5 to 6               | 13 to 9 | 1.2   | 13                  |
| 40 to 63   | 6 to 16                | 9 to 5  | 1.8   | 13                  |
| 80 to 100  | 16 to 35               | 5 to 2  | 3.8   | 20                  |
| 125<br>160 | 50 to 120<br>70 to 120 | 0<br>00 | 16.4 (or 28.8)<br>M10 nut (17 mm<br>wrench) to attach<br>eyelet and terminal. | ø 10 (or ø 12)      |

Table 2-2 Power connection details for ratings from 16 A to 160 A

Conductor cross-sections should comply with IEC 60943.

Use 75°C copper wire only.

### 2.3.2.3. Three-phase load wiring schemes

Power connections to the unit depend on the load configuration.

The following four configuration schemes may be used for three-phase loads:

- star without neutral (3 connection wires, code 3S), figure 2-7
- closed delta (3 connection wires, code 3D), figure 2-8
- star with neutral (4 connection wires, code 4S), figure 2-9
- open delta (6 connection wires, code 6D), figure 2-10.

| Configuration type   | Load voltage         | Load current                               | Important note   |
|----------------------|----------------------|--|--|
| Star without neutral | $V_{L-L} / \sqrt{3}$ | Current in one line of thyristors $I_{Th}$ | -  |
| Star with neutral    | $V_{L-N}$            | Current in one line of thyristors $I_{Th}$ | -  |
| Closed delta         | $V_{L-L}$            | $I_{Th} / \sqrt{3}$<br>Balanced load       | -  |
| Open delta           | $V_{L-L}$            | Current in one line of thyristors $I_{Th}$ | It is essential to connect the loads as shown in figure 2-10 |

Table 2-3 Characteristics of different balanced three-phase load configuration schemes

$V_{L-L}$ : Line-to-line voltage;  $V_{L-N}$ : Line-to-neutral voltage;  $I_{Th}$ : Thyristor line current











---

| Contents   | Page |
|--|------|
| <b>Alaram Diagnostic Strategy</b> .....                                    | 3-2  |
| <b>3.1. Safety mechanisms</b> .....  | 3-3  |
| <b>3.2. Alarm Signalling</b> .....   | 3-3  |
| <b>3.3. Alarm Strategy</b> .....   | 3-3  |
| <b>3.3.1. Setting DLF alarm</b> .....                                      | 3-5  |
| <b>3.3.2. Partial or Total Load failure detection</b> .....                | 3-5  |
| <b>3.3.3. Partial Load Failure detection sensitivity</b> .....             | 3-5  |
| <b>3.4. Signalling of channel for load fault</b> .....                     | 3-6  |
| <b>3.5. Load type matching</b> .....                                       | 3-6  |
| <b>3.6. Disabling alarm and diagnostic for load failure signalling</b> ... | 3-6  |
| <b>3.7. Functions od DLF alarm push button</b> .....                       | 3-7  |
| <b>3.7.1. Setting Request</b> .....  | 3-7  |
| <b>3.7.2. Diagnosis</b> .....  | 3-7  |
| <b>3.7.3. Disabling</b> .....  | 3-7  |





| Alarm                          | Alarm Indication |       |          |                | Alarm Reset | Alarm Duration |
|--------------------------------|------------------|-------|----------|----------------|-------------|----------------|
|                                | LED              | Relay | Flashing | Other          |             |                |
| Partial Load Failure (PLF)     | OFF              | OFF   | Flashing | ON or Flashing | No          | 5 s to 13 s    |
| Total Load Failure (TLF)       | OFF              | ON    | Flashing | ON or Flashing | No          |                |
| Thyristor Short-Circuit (THSC) | OFF              | ON    | OFF      |                |             |                |
| Over-temperature (T°)          | ON               | OFF   | OFF      | OFF*           | Yes         |                |

\* Even if the control signal is present.

The indicators for serious alarms detected return to normal (LEDs and relays in non-alarm position) after the fault condition ceases.

%

- The GRF option (Gross Fault) is automatically included with the DLF option.
- The DLF LED is used to distinguish between TLF or THSC faults.
- The DLF indicator flashes in a particular way to indicate the channel on which the load failure has occurred (see figure 4-3).
- The red T° LED is only fitted for fan-cooled units (rating ≥ 125 A) and if one of the alarm options is selected.

) # ! \$ %

Adjusting PLF detection involves calculating and storing the value of the reference impedance from the measured rms current and voltage values.

This can be set using the push button on the front panel. The PLF detection setting can only be adjusted (reference impedance recalculated) in the following conditions :

- rms voltage across load is greater than **40** % of the nominal voltage
- rms current is greater than **30%** of the rated current
- no over-temperature or thyristor short-circuit faults.
- each time PLF setting is required the three-phase load must be balanced.
- in order to guarantee the full scale sensitivity, settings must be done at the load's nominal temperature

Note : PLF settings stay memorised even if a supply cut-out occurred

- 3 \$ \$ & ! \$'

**Partial Load Failure PLF** monitoring involves comparing the load impedance with a reference impedance stored during setting. This comparison allows the detection of the load impedance increase. The load impedance is calculated from the continuous measure of the rms values of current and voltage.

PLF detection is only possible under the following conditions :

- no over-temperature or thyristor short-circuit faults.
- rms voltage across the load greater than **40%** of the nominal voltage and,
- rms load current greater than **5%** of the rated current.

**Total Load Failure TLF** monitoring is only possible under the following conditions :

- no over-temperature or thyristor short-circuit faults.
- the rms voltage across load is greater than **40** % of the nominal voltage

3 \$ & ! \$' 4 (

Partial Load Failure Detection Sensitivity can be expressed in terms of a **maximum number** of load elements connected in parallel for which the unit can detect the failure of one element. The DLF sensitivity guaranteed for identical three-phase loads connected in parallel is :

3D coupling - 1 element out of 3

3S, 4S and 6D coupling - 1 element out of 4







---

| Contents  | Page       |
|---|------------|
| <b>4.1. Safety during commissioning and maintenance</b> .....         | <b>4-2</b> |
| <b>4.2. Commissioning</b> .....                                       | <b>4-2</b> |
| <b>4.2.1. Checking the characteristics</b> .....                      | <b>4-2</b> |
| <b>4.2.1.1. Load current</b> .....                                    | <b>4-2</b> |
| <b>4.2.1.2. Supply voltage</b> .....                                  | <b>4-2</b> |
| <b>4.2.1.3. Input signal</b> .....                                    | <b>4-2</b> |
| <b>4.2.2. Checking wiring</b> .....                                   | <b>4-3</b> |
| <b>4.2.2.1. Cut-off and isolation systems</b> .....                   | <b>4-3</b> |
| <b>4.2.2.2. Protective earth, power and control connections</b> ..    | <b>4-3</b> |
| <b>4.2.3. Power up</b> .....  | <b>4-3</b> |
| <b>4.2.3.1. Power and auxiliary voltages and input signal</b> ...     | <b>4-3</b> |
| <b>4.2.3.2. Adjust the partial load failure detection setting</b> ... | <b>4-3</b> |
| <b>4.3. Maintenance</b> .....   | <b>4-4</b> |
| <b>4.4. Thyristor protection fuses</b> .....                          | <b>4-4</b> |









---

\*  
,

For over thirty years **Eurotherm Limited** have been providing an unparalleled level of service and expertise to customers in the control of Processes and Power.

From requirement assessment, through to equipment specification and plant commissioning.

**Eurotherm Limited** is able to offer expertise and equipment in the following areas:

- Input conditioning
- Process and Temperature Indicators
- Single Loop Process and Temperature Controllers with Programming facilities
- Programmable Multi loop Process Controllers
- Solid State Contactors
- Power Controllers
- Paper and Paperless Data Recorders
- Data Acquisition and Management Instrumentation
- Supervisory Systems (SCADA)
- Process Automation Systems

**Eurotherm** manufactures at a number of locations in Europe and the USA, and is a major supplier to the world's processing and manufacturing industries.

**Eurotherm Limited** is ISO9001 approved and operates TickIT protocols for software management.

Please contact your local **Sales Office**.