



**Three Phase  
Power  
Thyristor  
Units**



invensys  
**EUROTHERM**

**User  
Manual**

---

# **7300A ADVANCED CONTROLLERS**

## **THREE-PHASE POWER THYRISTOR UNITS**

### ***7000\* Series***

## **User Manual**

© Copyright Eurotherm Limited 2002

All rights reserved. All reproduction or transmission in any form whatsoever and using any procedure (electronic or mechanical, including photocopying and recording) without written permission from Eurotherm is strictly prohibited.

# COMMISSIONING FLOWCHART

**Note:** If the code does not correspond, go to the next step.

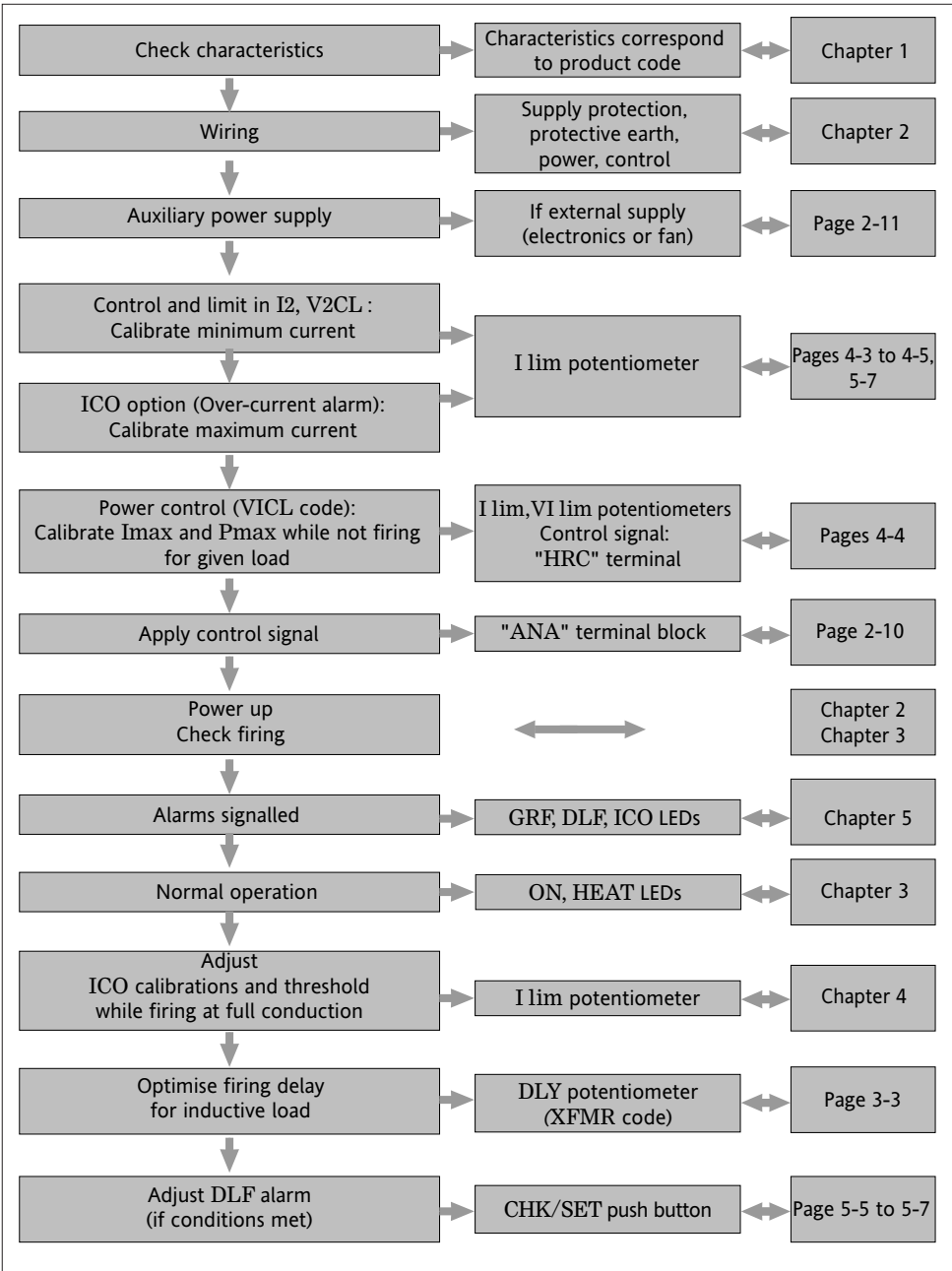

## CONTENTS

	Page
Commissioning flowchart .....	.ii
European Directives and applicable standards .....	.iv
<b>Chapter 1</b> Identification of power thyristor units .....	.1-1
<b>Chapter 2</b> Installation .....	.2-1
<b>Chapter 3</b> Firing modes .....	.3-1
<b>Chapter 4</b> Control and Limits .....	.4-1
<b>Chapter 5</b> Alarms .....	.5-1
<b>Chapter 6</b> Digital Communication .....	.6-1
<b>Chapter 7</b> Maintenance .....	.7-1
Eurotherm worldwide sales and service .....	.8-1

## PURPOSE OF MANUAL

This manual (Issue **3**) describes the Basic Version and all options for 7300A series three-phase power thyristor units with current ratings up to 160A.

## EUROPEAN DIRECTIVES AND APPLICABLE STANDARDS

### COMPLIANCE WITH PRODUCT STANDARD

7300A products comply with the terms of product standard **EN 60947-4-3** 'Contactors and motor-starters - AC semiconductor motor controllers and contactors for non-motor loads'.

### CE LABELLING

7300A products installed and used in accordance with the user manual, bear CE labelling on the basis of compliance with the essential requirements of the **European Low Voltage Directive** 73/23 EEC dated 19 February 1973, modified by 93/68/EEC dated 22 July 1993 and the **Electromagnetic Compatibility Directive** 89/336/EEC dated 3 May 1989 modified by 92/31/EEC dated 28 April 1992 and 93/68/EEC dated 22 July 1993.

### SAFETY

The units have IP20 protection rating as defined by standard IEC 60529.

External wiring must comply with standards IEC 60364-4-43 and IEC 60943.

Copper cables and conductors must be used, rated to a temperature of 75°C (167°F).

### ELECTROMAGNETIC COMPATIBILITY (EMC)

7300A products installed and used in accordance with the user manual, are designed for an industrial environment and must not be used in the home.

### EMC TEST STANDARDS

**IMMUNITY** - The EMC immunity test standards required by the standard EN 60947-4-3 'Contactors and motor-starters - AC semiconductor motor controllers and contactors for non-motor loads' are presented below.

Test type	Standard	Behaviour criterion
Electrostatic discharge	EN 61000-4-2	2
Radiated, radio frequency electromagnetic field	EN 61000-4-3	1
Electrical fast transient / burst	EN 61000-4-4	2
Surge	EN 61000-4-5	2
Conducted disturbances induced by radio frequency fields	EN 61000-4-6	1
Voltage dips, short interruptions and voltage variation	EN 61000-4-11	2

**EMISSIONS** - The EMC emissions test standards required by the standard EN 60947-4-3 'Contactors and motor-starters - AC semiconductor motor controllers and contactors for non-motor loads' are presented below.

Emission type	Firing mode	Test standard
Radiated at radio frequencies	All firing	CISPR 11 Class A modes
Conducted at radio frequencies 'S single-cycle' 'Phase angle'	Burst mode' and CISPR 11Product	CISPR 11 Class A Group 2 Class A 2 compliant if external filter fitted

### EMC GUIDE

To help you deal with installation-dependent electromagnetic interference effects, Eurotherm provides an 'Electromagnetic compatibility' installation guide (ref. HA 025464 ENG) which sets out best current practice regarding EMC.

**DECLARATION OF CONFORMITY CE** is available on request.

# Chapter 1

## IDENTIFICATION OF POWER THYRISTOR UNITS

Contents	Page
1.1. General presentation .....	1-2
1.2. Technical specifications .....	1-5
1.2.1. Use .....	1-5
1.2.2. Power .....	1-5
1.2.3. Load .....	1-5
1.2.4. Signalling .....	1-5
1.2.5. Dimensions .....	1-5
1.2.6. Command .....	1-6
1.2.7. Firing Modes .....	1-6
1.2.8. Control .....	1-6
1.2.9. Alarms .....	1-7
1.2.10. Protection .....	1-8
1.2.11. Mounting .....	1-8
1.2.12. Environment .....	1-8
1.2.13. Digital Communication .....	1-9
1.3. Coding .....	1-10

# Chapter 1 - IDENTIFICATION

## 1.1. GENERAL PRESENTATION

7300A series power thyristor units are used to control the electrical power of **three-phase** industrial loads of all types.

The load controlled may comprise high or low temperature coefficient resistive loads, short wave infrared elements or transformer primaries.

Current ratings vary from **16A to 160A** (per phase), at line-to-line voltages of **200V to 500V**.

A 7300A series thyristor unit comprises three channels, controlled by thyristors.

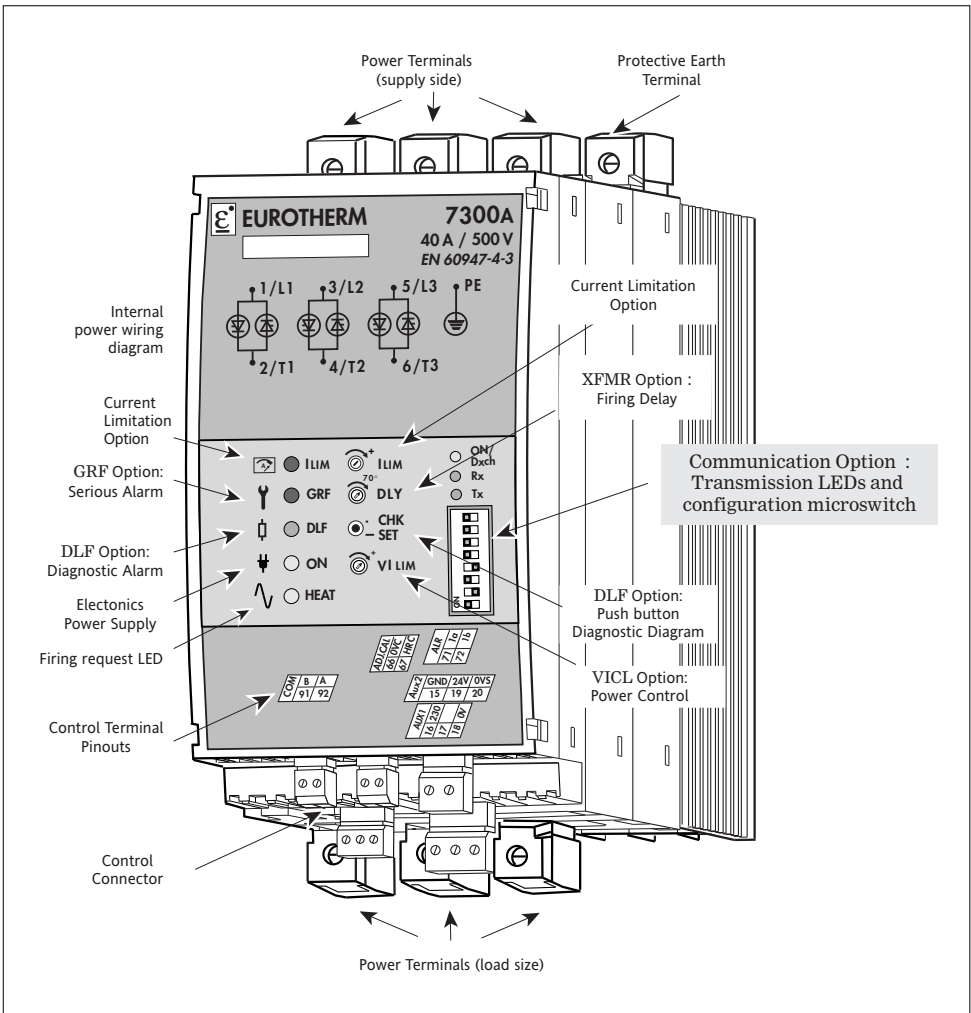

Figure 1-1 General view of 7300A power thyristor unit from 16 to 40A

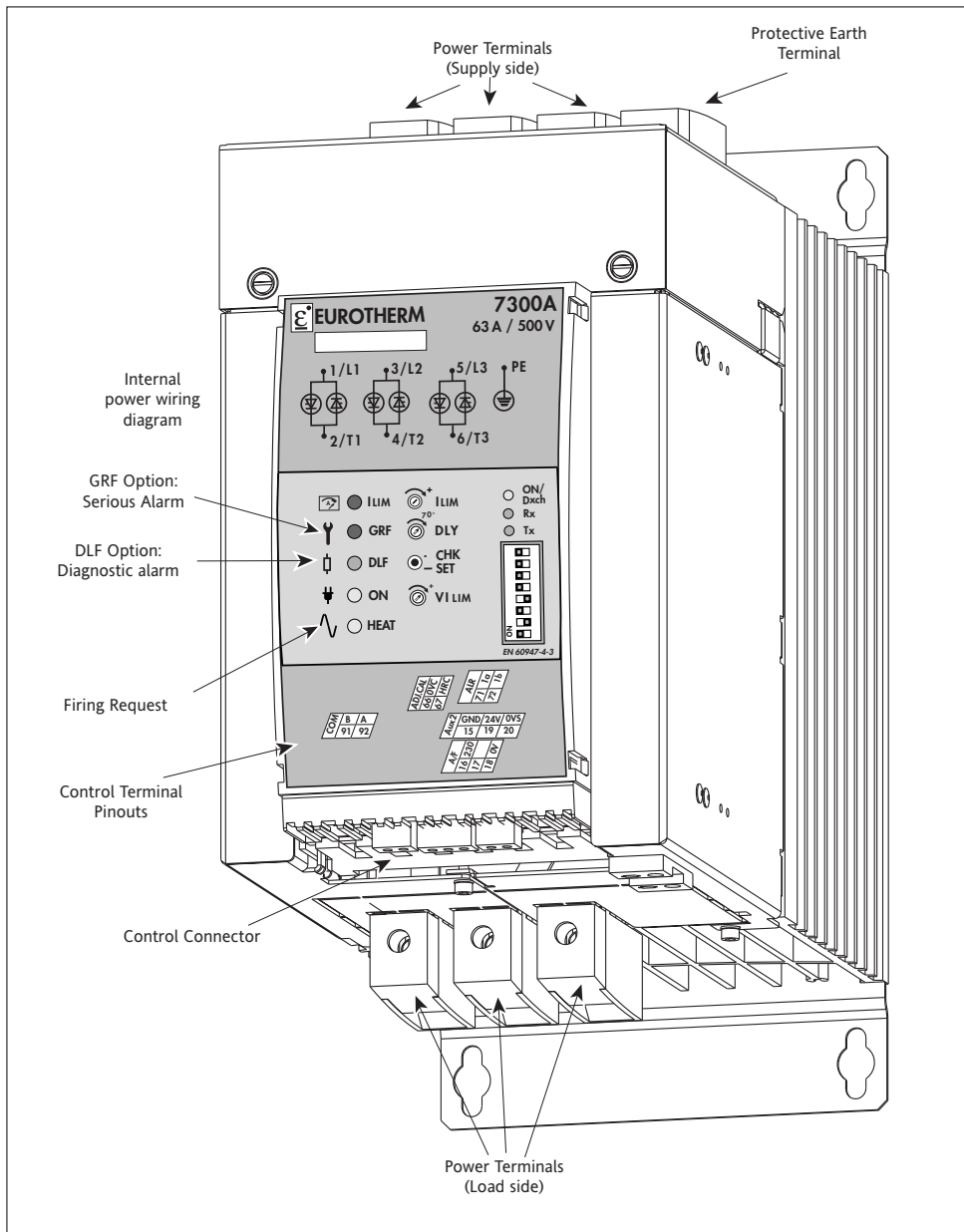

Figure 1-2 General view of 7300A unit from 63A to 100A

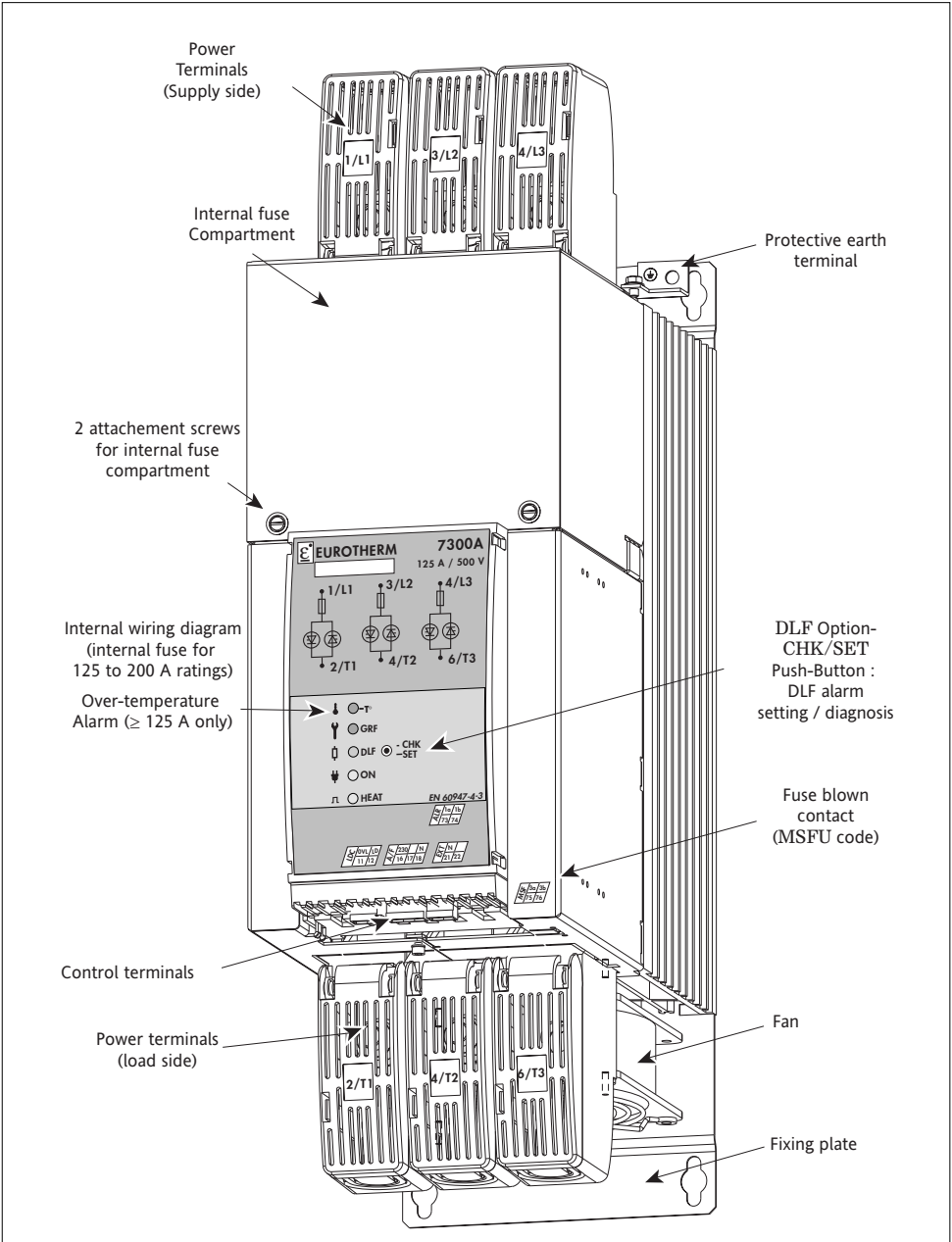

Figure 1-3 General view of 7300A units  $\geq 125$ A

## 1.2. TECHNICAL SPECIFICATIONS

### 1.2.1. Use

Thyristor unit, variant 4 (see Standard EN 60947-4-3) for uninterrupted service.

### 1.2.2. Power

Nominal current per phase  
Nominal line to line voltage  
Frequency  
Dissipated power  
Cooling

16A to 160A at 45°C (see product code)  
200V to 500V (see code).  
Use from 47 to 63Hz (automatic matching)  
1.3W (approx.) per amp and per phase  
ratings ≤ 100A: Natural convection  
ratings ≥ 125A: Fan-cooled.

### 1.2.3. Load

Categories of use

Three-phase Industrial Load.  
The categories of use applicable for each unit are indicated on the identification label

- AC-51 Non-inductive or low inductance loads, furnace resistances (Resistive load with low temperature coefficient).
- AC-55b Switching of incandescent lamps, for units 100A (Short wave infrared elements, SWIR).
- AC-56a Switching of transformers (Transformer primaries and high temperature coefficient resistive loads).

Options must be fitted to 7300A units in order to comply with certain categories of use.

Connections

Load configuration

Independent of phase rotation order  
Star with or without neutral, open or closed delta.  
Configuration on order.

### 1.2.4. Signalling

Electronics supply present (green 'ON' LED) and supply fault detection ('ON' LED flashing).  
Thyristor firing request: (green 'HEAT' LED).

### 1.2.5. Dimensions

Rating	Height	Width	Depth (mm)		
			Base	With Option(s) or Modbus Comms	With Option(s) and Modbus Comms
16A to 40A	220mm	96mm	214	239	264
63A to 100A	305mm	144mm	372	372	372
125A to 160A	498mm	144mm	372	372	372

## 1.2.6. Command

Supply

Self-powered from line or external power supply  
(115V or 230V +10%; -15%) depending on order code.

Consumption: 10VA.

Control type

Analogue (digital communication optional)

- either remote analogue setpoint:  
0-5V or 0-10V (100 k $\Omega$  input),  
0-20mA or 4-20mA (250  $\Omega$  input)
- or manual setpoint (potentiometer):  
5V user voltage output available (max. 2mA).

## 1.2.7. Firing modes

*Zero crossing firing*

- Burst mode, base time: 16 or 64 cycles
- Single-cycle, 1 base cycle
- Advanced single-cycle, 1 base cycle  
firing by whole cycles,  
non-firing by half cycles;  
(not available for 3S and 3D three-phase load  
configuration)

*Firing angle variation*

- Phase angle

## 1.2.8. Control

Control parameter

- Standard (on balanced three-phase supply):  
Load voltage squared ( $V^2$ )
- Option:
  - Apparent power ( $V \cdot I$ )  
with mean of 3 phase currents
  - Mean of square of 3 load currents ( $I^2$ ) in  
Phase angle mode
  - Open loop in Phase angle mode.

Linearity and Stability

Better than  $\pm 2\%$  of full scale.

Current limit

Option, depending on firing mode:

- Phase angle:  
Automatic control transfer:  
 $V^2 \leftrightarrow I^2$ , or  $V \cdot I \leftrightarrow I^2$ ,
- Current recalibration set by potentiometer on front panel.
- Burst mode, 16 cycle base:  
Current limit with threshold, set by potentiometer on  
front panel.

Safety ramp

After each power up or after stopping firing for 5 s or more  
(Burst mode firing with Phase angle limiting).

Calibration

A control signal is available in  $V \cdot I$  control for power and  
current calibration and for maintenance.

Transient current limit

Option to control transformer primaries  
in Burst mode:

- Magnetisation ramp in phase angle variation on first  
power up.
- Adjustable delay for first firing.

## 1.2.9. Alarms

### Standard alarms

Supply fault	Supply voltage absent on one or three phases. Frequency outside operating frequency. Cut off.
Operation	Without options: 'ON' LED
Signalling	With alarm option: 'ON' LED and alarm relay.
Open circuit Neutral	In 'Star with neutral' coupling and for DLF option and/or power control. Cut off.
Operation	VII2 and VICL options: 'ON' and 'GRF' LEDs.
Signalling	DLF option: 'ON' and 'GRF' LEDs, alarm relay.
Over-temperature alarm	For all fan-cooled units 125A, the unit cuts out if the temperature threshold is exceeded.
Signalling	Red 'T°' LED if one of the monitoring alarms is selected. Alarm relay contact with any alarm.

### Load monitoring alarms (Options)

Serious alarms ( <i>GRF option</i> )	Total load failure and thyristor short circuit detection.
Signalling	Red 'GRF' LED and alarm relay contact
Diagnostic alarm ( <i>DLF option</i> )	Partial load failure detection.
Signalling	Orange 'DLF' LED and alarm relay contact.
Settings	Monitoring diagnosis, alarm adjustment and resetting using push button on front panel.
Sensitivity	Detects the failure of at least one heating element for three or four identical elements, connected in parallel, depending on the configuration
Extension	The DLF option includes Serious alarm monitoring (GRF).

### Over Load alarm (Option)

Operation ( <i>ICO option</i> )	Cut-out if current threshold exceeded Only available for <i>Zero crossing</i> firing with <i>DLF</i> option (not compatible with <i>Short wave infrared</i> elements, <i>Transformers</i> and <i>VICL</i> and <i>V2CL options</i> ). Two alarm thresholds: instantaneous current and rms current. Simultaneous current threshold adjustment (recalibration of thyristor unit): from 20 to 100% using potentiometer on front panel.
Signalling	Red 'ICO' LED and alarm relay contact. Acknowledged by logic input.

### Alarm relay

Available with load monitoring and over load alarm.  
The relay contact (0.25A/230Vac; 32Vdc) is either open on alarm or closed on alarm depending on the product code.

### 1.2.10. Protection

Co-ordination type  
Electrical protection  
Thyristors

For short circuits. Load monitoring.  
IP20 without adding additional protection.  
Varistor and RC snubber.  
High speed fuses:  
• rating 100A: external (see code, section 6)  
• rating 125A: internal (under development).  
No fuses for Short wave infrared elements  
in Burst mode and Single-cycle firing, or  
Phase angle without Current limit.  
See section 7.

Fuse characteristics

### 1.2.11. Mounting

Mounting

Attachment plate fixed to unit:  
• on symmetrical EN50022 DIN rail or  
• bulkhead mounting  
(for ratings 63A: bulkhead mounting only).

### 1.2.12. Environment

Use  
Storage  
Isolation voltage  
Pollution  
Humidity  
Over-voltage

0 to 45°C at nominal current, max altitude 1000m  
-10°C to 70°C.  
Assigned isolation voltage  $V_i = 500V$ .  
Degree 2 acceptable (defined by IEC 60664).  
RH 5% to 95%, non-condensing, non-streaming.  
Over-voltage category II (as defined by IEC 60664)

### 1.2.13. Digital Communication

Protocol	Modbus RTU
Compliance	Communication complies with the specifications given in 'GOULD MODICON Protocol Reference Guide PI-MBUS-300 rev J'
Power supply	24Vac ( $\pm 20\%$ ), 47 to 63Hz to 24Vdc ( $\pm 20\%$ ) non-polarised (filtered). Typical consumption 1.5VA. Protection: External fuse 1A. External wiring must comply with the IEC 60364 standard.
Transmission	Standard RS485 2 wires. Speed 9600 to 19200 bauds. Selection by the front panel microswitch (SW8).
Termination	The communication bus must have termination resistors fitted at each end: <ul style="list-style-type: none"><li>• one line impedance matching resistor.</li><li>• two RS485 bus polarisation resistors.</li></ul>
Address	Selection by switches on front panel only, between 1 to 127. Physical address 32 is configured by default.
Diagnostics	<ul style="list-style-type: none"><li>• Green LED on front panel indicates that power is applied and the unit is awaiting communications.</li><li>• Two orange LEDs (Rx and Tx) indicate the communication status (sending and receiving)</li></ul>
Other parameters	Read and Write by digital communication.

## 1.3. CODING

### Ratings

1. Nominal current per phase	Code
16 amps	<b>16A</b>
25 amps	<b>25A</b>
40 amps	<b>40A</b>
63 amps	<b>63A</b>
80 amps	<b>80A</b>
100 amps	<b>100A</b>
125 amps	<b>125A</b>
160 amps	<b>160A</b>

2. Nominal line to line voltage	Code
200 volts	<b>200V</b>
220 volts	<b>220V</b>
230 volts	<b>230V</b>
240 volts	<b>240V</b>
277 volts	<b>277V</b>
380 volts	<b>380V</b>
400 volts	<b>400V</b>
415 volts	<b>415V</b>
440 volts	<b>440V</b>
460 volts	<b>460V</b>
480 volts	<b>480V</b>
500 volts	<b>500V</b>

3. Power supply for electronics	Code
Self-powered	<b>SELF</b>
External 115V supply	<b>115V</b>
External 230V supply	<b>230V</b>

4. Fan power supply	Code
≤ 100A: No fan	<b>XXXX</b>
≥ 125A: - 115V fan and 115V	<b>115V</b>
- 230V fan and 230V	<b>230V</b>

### Basic selection

5. Load configuration	Code
Star without Neutral	<b>3S</b>
Star with Neutral	<b>4S</b>
Closed delta	<b>3D</b>
Open delta	<b>6D</b>

6. Thyristor fuse	Code
Fuse without fuse blown microswitch	<b>FUSE</b>
Fuse with fuse blown microswitch	<b>MSFU</b>
No fuse	
Short wave infrared elements <i>(Burst mode or single-cycle or Phase angle without limit)</i>	<b>NONE</b>

7. Firing mode	Code
<i>Phase angle</i>	<b>PA</b>
Burst mode:	
base time 16 cycles	<b>C16</b>
base time 64 cycles	<b>C64</b>
'Single-cycle': 1 base cycle	<b>FC1</b>
Advanced single-cycle: 1 base cycle	
non-firing by half cycles	
4S and 6D coupling only	<b>ASC</b>

8. Input	Code
Analogue signal:	
current from 0mA to 20mA	<b>0mA20</b>
current from 4mA to 20mA	<b>4mA20</b>
voltage from 0V to 5V	<b>0V5</b>
voltage from 0V to 10V	<b>0V10</b>

9. Manual language	Code
French	<b>FRA</b>
English	<b>ENG</b>
German	<b>GER</b>

10. Selected options	Code
Base version: No options, Standard V <sup>2</sup> control <b>End of code</b>	<b>NONE</b>
Version with options: Selection of options	<b>YES</b>

**Options**

11. Control options	Code
Voltage control	<b>V2</b>
PA only: Current control Open loop	<b>I2</b> <b>OL</b>
PA or C16: Voltage control and Current Limitation Power control and Current Limitation	<b>V2CL</b> <b>VICL</b>

12. Delay on first firing	Code
<i>Burst firing C16 or C64:</i> Transformer primary Other configurations	<b>XFMR</b> <b>XXXX</b>

13. Load Monitoring	Code
Serious Alarms: Thyristor short-circuit, Total Load failure, over-temperature for ratings $\geq 125$ A	<b>GRF</b>
Partial load failure and Serious alarms	<b>DLF</b>
No alarms	<b>NONE</b>

14. Load type	Code
With DLF option: Short wave infrared Low temperature coefficient load	<b>SWIR</b> <b>LTCL</b>
<i>Without DLF option or</i> High temperature coefficient load	<b>XXXX</b>

15. Over Load Alarm (with DLF option)	Code
Alarm, in burst firing mode only <i>except codes</i> SWIR, XFMR, VICL, V2CL and PA	<b>ICO</b>
<b>No over-current alarm</b>	<b>XXXX</b>

16. Alarm relay contact	Code
<i>With alarm option:</i> Contact closed on alarm Contact open on alarm	<b>NC</b> <b>NO</b>
<i>Without alarm option</i>	<b>XX</b>

**Communication and Certification**

17. Communication	Code
Digital Communication ModBus Protocol	<b>MOP</b>
<b>Without Communication</b>	<b>NONE</b>

18. Transmission speed	Code
Without communication	<b>XXXX</b>
Code MOP: transmission speed 9,6 KBauds 19,2 KBauds	<b>9K6</b> <b>19K2</b>

19. Certification option	Code
No certificate of 'Compliance with Order'	<b>NONE</b>
Certificate of 'Compliance with Order'	<b>CFMC</b>

20. Warranty extension	Code
Without warranty extension	<b>NONE</b>
Warranty extended to 5 years	<b>WL005</b>



## Chapter 2

### INSTALLATION

Contents	Page
<b>2.1. Safety during installation</b> .....	2-2
<b>2.2. Mounting</b> .....	2-3
<b>2.2.1. Types of mounting</b> .....	2-3
<b>2.2.2. Attachment plates</b> .....	2-3
<b>2.2.3. Mounting on DIN rails</b> .....	2-3
<b>2.2.4. Bulkhead mounting</b> .....	2-4
<b>2.3. Wiring</b> .....	2-5
<b>2.4. Power connections</b> .....	2-7
<b>2.4.1. General</b> .....	2-7
<b>2.4.2. Power connection details</b> .....	2-7
<b>2.4.3. Three-phase load configuration diagram</b> .....	2-7
<b>2.5. Control connections</b> .....	2-9
<b>2.5.1. Control terminal blocks</b> .....	2-9
<b>2.5.2. Control signal</b> .....	2-10
<b>2.5.3. Connecting the reference neutral voltage</b> .....	2-10
<b>2.5.4. MSFU option, fuse blown contact - MSF Terminal</b> .....	2-11
<b>2.5.5. External power supply terminal block</b> .....	2-11
<b>2.5.6. Alarm relay contact</b> .....	2-12
<b>2.5.7. Acknowledgement signal</b> .....	2-13
<b>2.5.8. Communication bus connection</b> .....	2-14
<b>2.8.1. Polarity</b> .....	2-14
<b>2.8.2. Wires screening</b> .....	2-14
<b>2.8.3. Termination resistors</b> .....	2-14
<b>2.8.4. Power supply connection 'AUX2'</b> .....	2-14
<b>2.8.5. Digital communication wiring</b> .....	2-15

## Chapter 2 - INSTALLATION

### 2.1. SAFETY DURING INSTALLATION (MOUNTING AND WIRING)

#### Danger!



- 7300A power thyristor units must be installed and wired by qualified staff authorised to work on low voltage industrial electrical facilities.

- Units must be installed in a fan-cooled cabinet, to ensure that condensation and pollution are excluded, with a class of at least 2 according to IEC 60664.

We recommend fitting fan-cooled cabinets with a fan failure detection device or a thermal safety cut-out.

The cabinet must be closed and connected to the protective earth according to IEC 60364 or applicable national standards.

#### Important!



- Units must be mounted with the heatsink positioned vertically, and with no obstructions above or below the unit which could reduce or hamper air flow. If several units are fitted in the same cabinet, arrange them such that air from one unit is not drawn in by the unit above.

The ambient temperature beneath the unit must not exceed 45°C.  
Leave a gap of at least 10 mm between adjacent units.

#### Important!



- Nominal currents correspond to use at ambient temperatures of no more than 45°C. Overheating may cause incorrect operation and may even lead to components being damaged.

#### Danger!



- It is the user's responsibility to wire and protect the facility according to best practice and applicable standards.

A suitable device, ensuring that the unit can be electrically isolated from the supply, must be installed upline to enable work to be performed safely.

Conductor cross-sections should comply with IEC 60943.

Only use copper cables and wires rated for use at 75°C.

- Before connecting or disconnecting the unit check that power and control cables and leads are isolated from voltage sources.

The protective earth must be connected before any other connections are made and should be the last cable to be disconnected.

The protective earth connection terminal is marked with the symbol:



#### Important!



- To ensure that 7300A power thyristor units comply with Electromagnetic Compatibility requirements, ensure that the panel or DIN rail to which they are attached is correctly grounded.

The ground connection, designed to ensure **ground continuity**, is not in any way a substitute for the protective earth connection.

## 2.2. MOUNTING

### 2.2.1. Types of mounting

Two types of mounting are possible:

- DIN rail mounting or
- bulkhead mounting with screws

Current rating	DIN rail mounting		Bulkhead mounting	
	Attachment plate	DIN rail	Attachment plate	Screws
16A to 40A	Two horizontal plates	Two EN 50022 symmetrical rails	Two horizontal plates	4 x M4
≥ 63A	N/A		Two horizontal plates	4 x M6

Table 2-1 Attachment details for both mounting types

### 2.2.2. Attachment plates

Two factory-fitted attachment plates on the rear of the 7300A thyristor units are used:

- to clip the unit to a DIN rail, or
- to screw the unit to a bulkhead.

Each attachment plate has:

- attachment holes for bulkhead mounting, and
- two fixed hooks and two mobile hooks for clipping to a DIN rail. (the mobile hooks are moved using a catch and spring).

### 2.2.3. Mounting on DIN rails

For **DIN rail** mounting:

- fix two symmetric DIN rails (for units rated 16A to 40A) in accordance with the unit dimensions and safety recommendations.
- bring the unit up against the top rail, engaging the two fixed hooks on the top attachment plate
- push the unit against the rail
- clip the unit onto the bottom rail using the mobile hooks on the bottom attachment plate, ensuring that they are properly engaged.

To **remove** the unit:

- move the mobile hooks downward by pulling the catch on the bottom attachment plate
- unclip the unit from the rail.

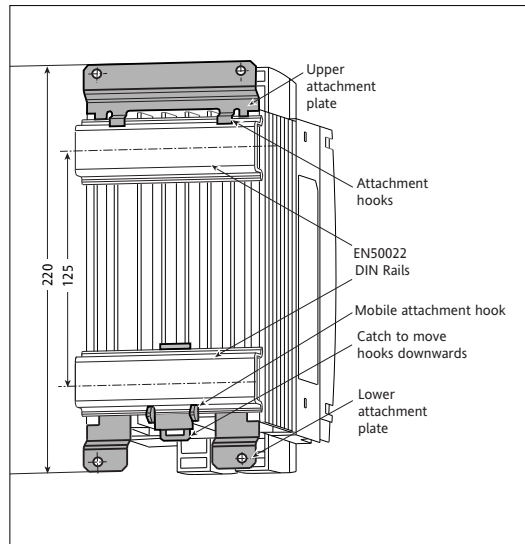

Figure 2-1 Attaching the 7300A ≤ 40A units to DIN rails

### 2.2.4. Bulkhead mounting

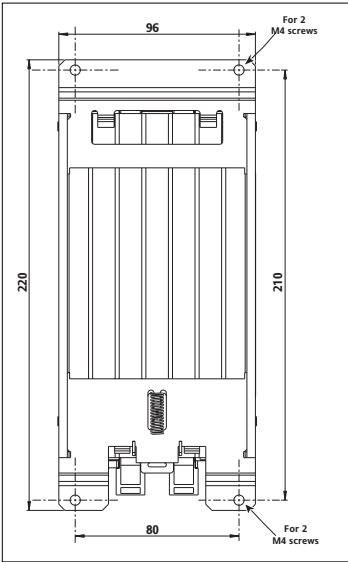

Figure 2-2 Bulkhead mounting - 16 A to 40 A units

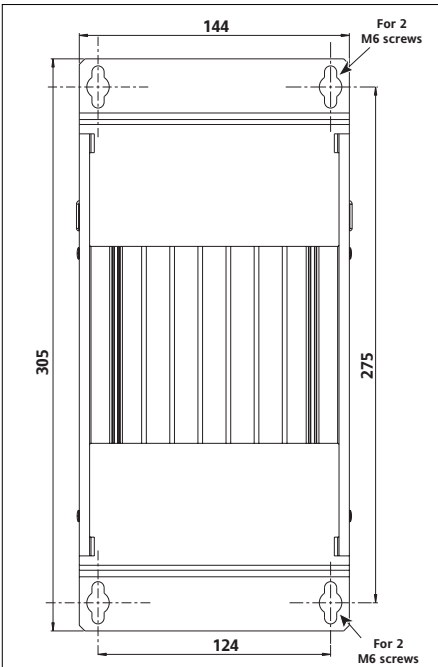

Figure 2-3 Bulkhead mounting - 63A to 100A units

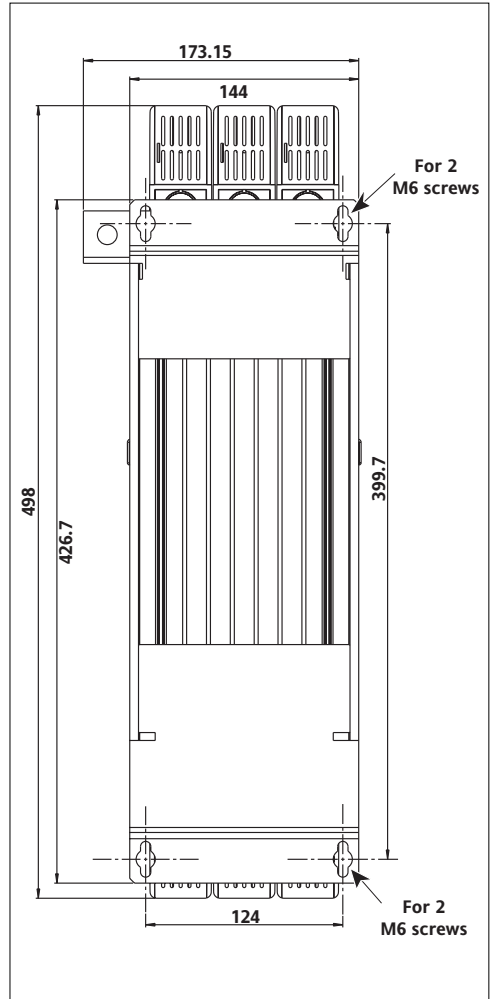

Figure 2-4 Bulkhead mounting -  $\geq 125A$  units

## 2.3. WIRING

### GENERAL CONNECTION DIAGRAM

The general connection diagram shows the power terminals (independently of the three-phase load configuration) and control connectors.

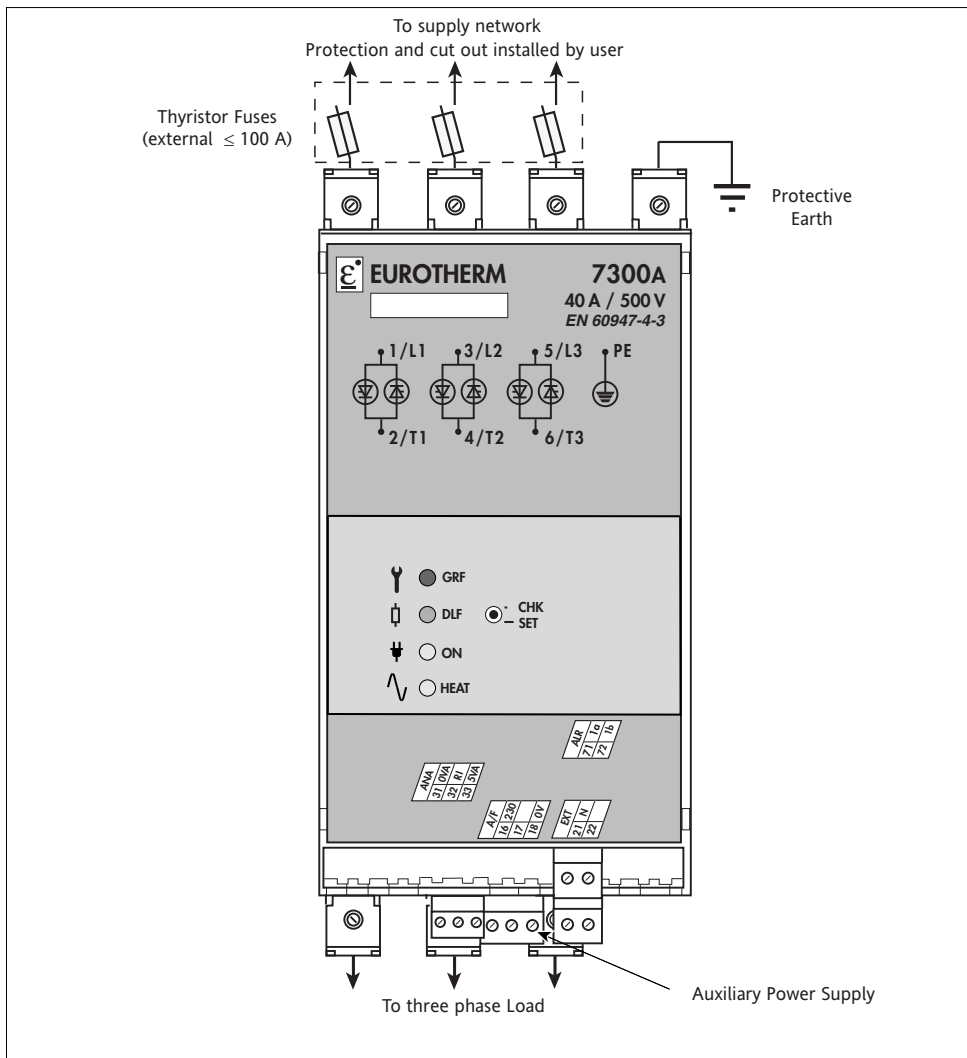

Figure 2-5 General connection diagram - units  $\leq 100A$

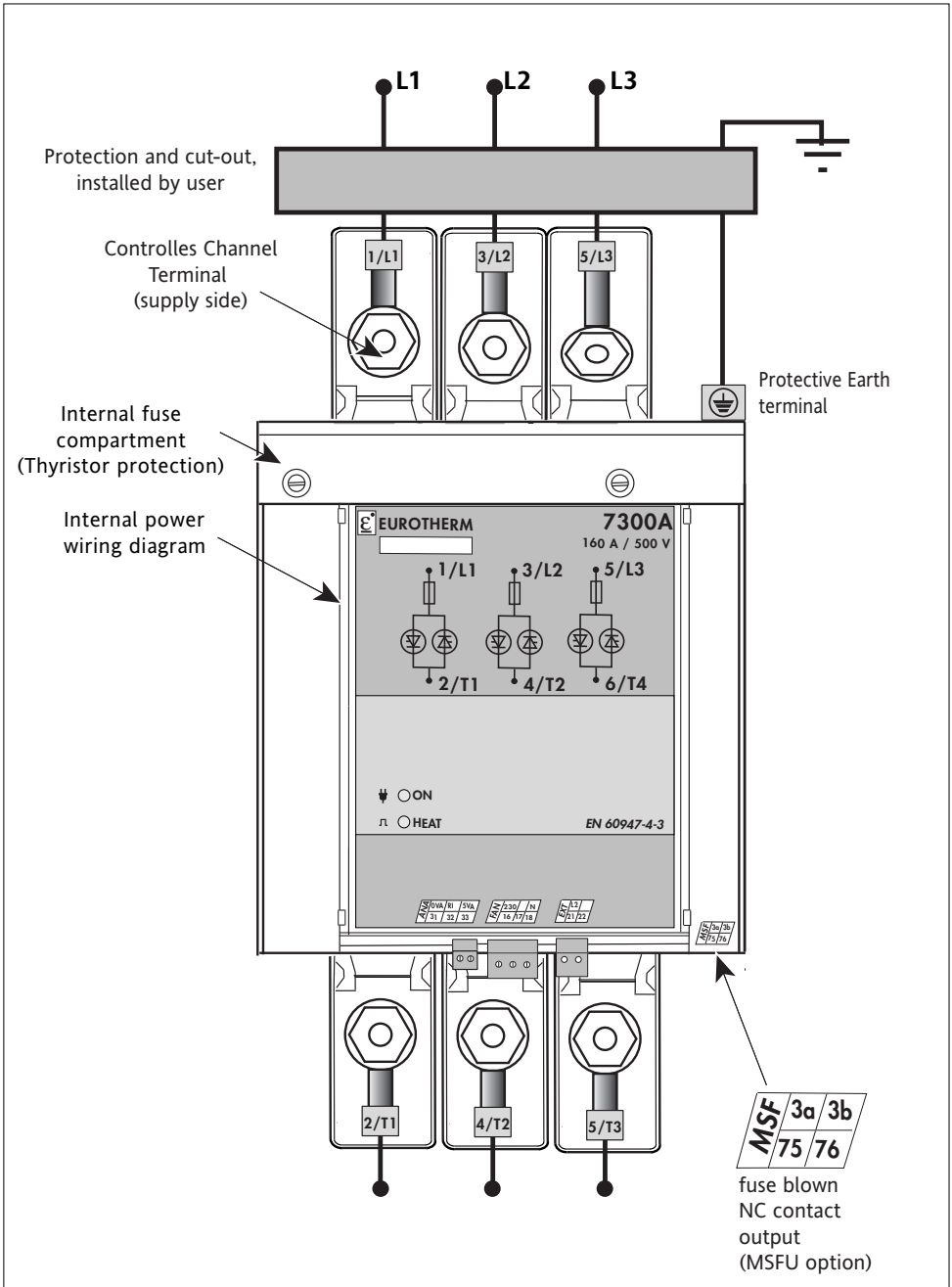

Figure 2-6 General Diagram for units  $\geq 125A$

## 2.4. POWER CONNECTIONS

### 2.4.1. General (Ratings from 16A to 160A)

7300A power thyristor units comprise three channels controlled by thyristors. Terminals **1/L1**, **3/L2** and **5/L3** must be wired to the three-phase supply network. Terminals **2/T1**, **4/T2** and **6/T3** must be wired to the three-phase load. The protective earth terminal **PE** (marked with the earth symbol) must be wired to the

### 2.4.2. Power connection details

Rating ( A )	Terminal capacity		Torque Nm	Stripping length mm
	mm <sup>2</sup>	AWG		
16 to 25	2.5 to 6	13 to 9	1.2	13
40 to 63	6 to 16	9 to 5	1.8	13
80 to 100	16 to 35	5 to 2	3.8	20
125 160	50 to 120 70 to 120	0 00	16,4 (or 28,8) M10 nut to attach eyelet and terminal	ø 10 (or ø 12)

Table 2-2 Power connection details for ratings from 16A to 160A  
Conductor cross-sections should comply with IEC 60943.

Use at 75°C min. copper wire only

### 2.4.3. Three-phase load wiring schemes

Power connections to the thyristor unit depend on the load configuration scheme. The following four configuration schemes may be used for three-phase loads:

- star without neutral (3 connection wires, code 3S), figure 2-7
- star with neutral (4 connection wires, code 4S), figure 2-8
- closed delta (3 connection wires, code 3D), figure 2-9
- open delta (6 connection wires, code 6D), figure 2-10

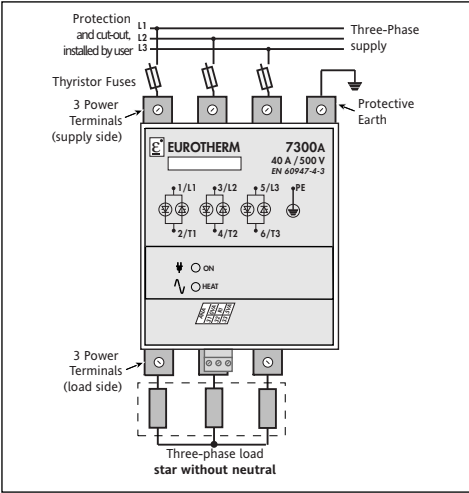

Figure 2-7 Connecting a three-phase load using star without neutral configuration (3S)

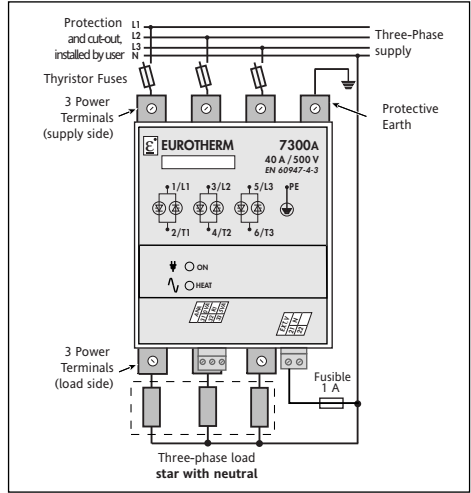

Figure 2-8 Connecting a three-phase load using star with neutral configuration (4S)  
 Note: Connection to EXT terminal in case of option VI CL, V2CL, GRF or DLF

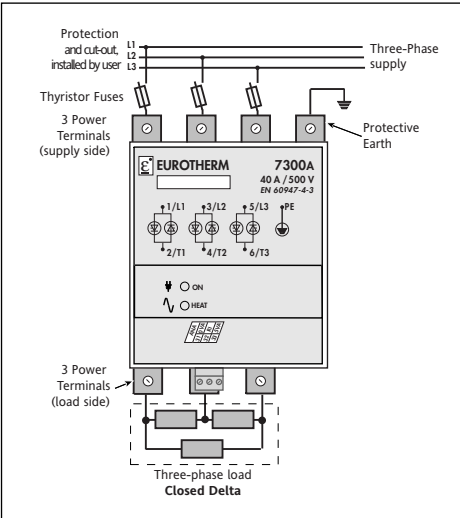

Figure 2-8 Connecting a three-phase load using closed delta configuration (3D)

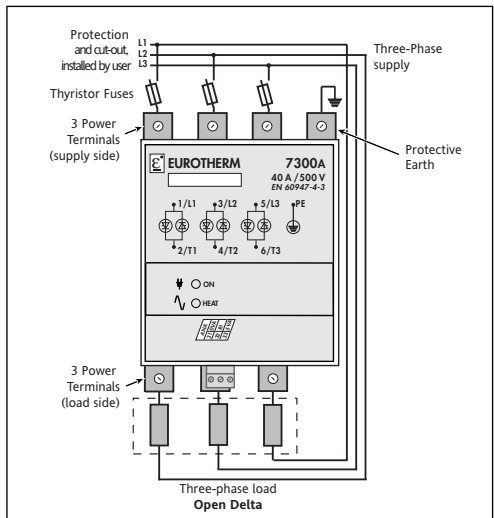

Figure 2-10 Connecting a three-phase load using open delta configuration (6D)

## 2.5. CONTROL CONNECTIONS

Terminal blocks on the underside of the 7300A power thyristor unit are used to connect:

- the control signals (analogue and logic)
- the auxiliary or electronics supply and the neutral
- alarm relay and acknowledgement contacts

The wires used should be stripped for a length of 6 to 7mm.

### 2.5.1. Control terminal blocks

The control terminal blocks are plug-in screw connectors.

The terminal blocks available depend on the power thyristor unit version and the selected options in the product code.

The terminal names and numbers are marked on the front panel for available terminal blocks. The table below gives details of all terminals and terminal blocks.

Version	Terminal block name	Terminal description			Terminal capacity		Torque Nm
		No.	Name	Purpose	mm <sup>2</sup>	AWG	
Basic or Options	<b>ANA</b>	31	0VA	0V for analogue signals	1.5	16	0.5
		32	RI	'+' for analogue signals			
		33	5VA	5V user output			
	<b>A/F</b> (except SELF)	16	230	230V aux. supply	2.5	14	0.7
17	115	115V aux. supply					
18	0V	Neutral or second phase					
Option ICO	<b>DIG</b>	61	0VD	0V logic signal	1.5	16	0.5
		62	ACK	Alarm acknowledgement			
		63	5VD	5V user output			
Options Alarms	<b>ALR</b>	71	1a	Alarm relay	2.5	14	0.7
		72	1b	contact (code NC)			
		73	1a	Alarm relay			
		74	1b	contact (code NO)			
Option: DLF, VICL	<b>EXT</b>	21	N	Supply Neutral for 4S	2.5	14	0.7
		22		Not connected			
	<b>MSF</b>	75	3a	Fuse blown NC contact	2.5	14	0.7
		76	3b	Microcontact 125A			
Option VICL	<b>ADJ.CAL</b>	66	0VC	0V calibration	1.5	16	0.5
		67	HRC	Calibration control			
Digital Comms Option	<b>AUX2</b>	19	24V	Auxiliary power supply	2.5	14	0.7
		20	0VS				
		29	GND				
	<b>COM</b>	91	B	Comme connector	2.5	14	0.5
		92	A				

Table 2-3 Description of control terminal blocks

## 2.5.2. Control signal

The analogue control signal terminal block is labelled **ANA**.

Input Signal:

The input available corresponds to the input type selected in the product code (specified range of voltage or current). The signal must be connected between terminals **32** and **31**.

The '+' of the control signal must be connected to terminal **32** (labelled **RI**).

A typical external signal connection is shown on figure 2-11a.

Manual Control:

Figure 2-11b shows how to use the internal **5V** voltage (terminal **33** labelled **5VA**) for manual control with an external **10k potentiometer** (input code **0V5** only).

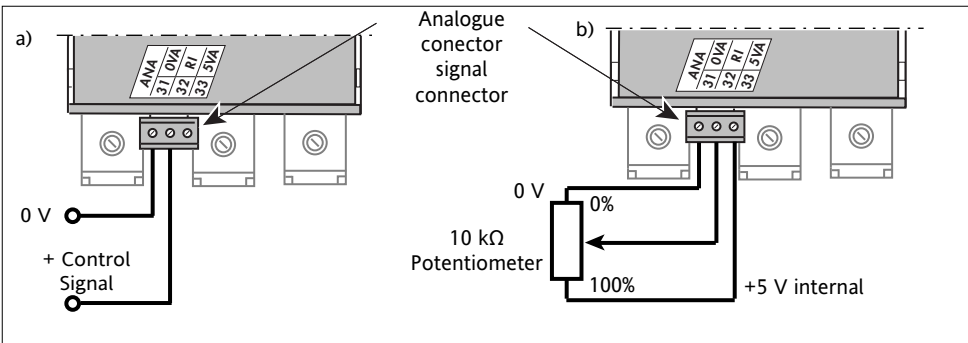

Figure 2-11 Control signal connection (self-powered unit, base version)

a) external signal, e.g. from Eurotherm series 2000 controller

b) manual command from external potentiometer.

## 2.5.3. Connecting the reference neutral voltage

In 4S load configuration, to enable the Diagnostic **DLF** and the power control **VICL** the neutral voltage of the three-phase supply (**reference neutral**) must be applied to terminal **21**, marked **N (EXT)** connector).

This connection of reference neutral voltage, enables to measure the real load potential.

This connection must be protected by a **1A** fuse (see figure 2-12).

Loss of the reference neutral connection causes an alarm (see Alarms section)

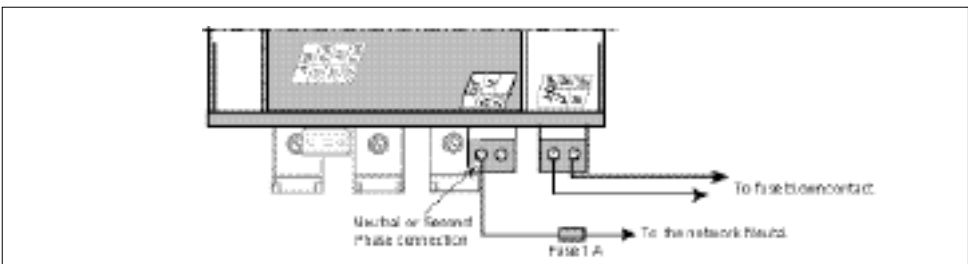

Figure 2-12 Connecting the supply neutral voltage (code 4S and DLF, VICL)

## 2.5.4. MSFU option, fuse blown contact - MSF Terminal

For any units from 125A to 160A, with the option MSFU a contact is available on the terminal MSF in order to indicate fuse blown.

## 2.5.5. External power supply terminal block

### Power supply for electronics and fan (A/F)

• **The power supply for the electronics** may be either:

- internal (self-powered, code **SELF**) or
- external, **115V** or **230V** depending on the product code

Only one terminal (**16** for 230V or **17** for 115V) is available depending on the product code.

• **The power supply for the fan:**

For units from 125A and above, the fan must be powered on with an external power supply **115V** or **230V** depending on the product code. The same code A/F is used. (Terminal **16** for 230V or **17** for 115V depending on the product code).

It also possible to combine the power supply for electronics and the power supply for the fan, **115V** or **230V** (both the same).

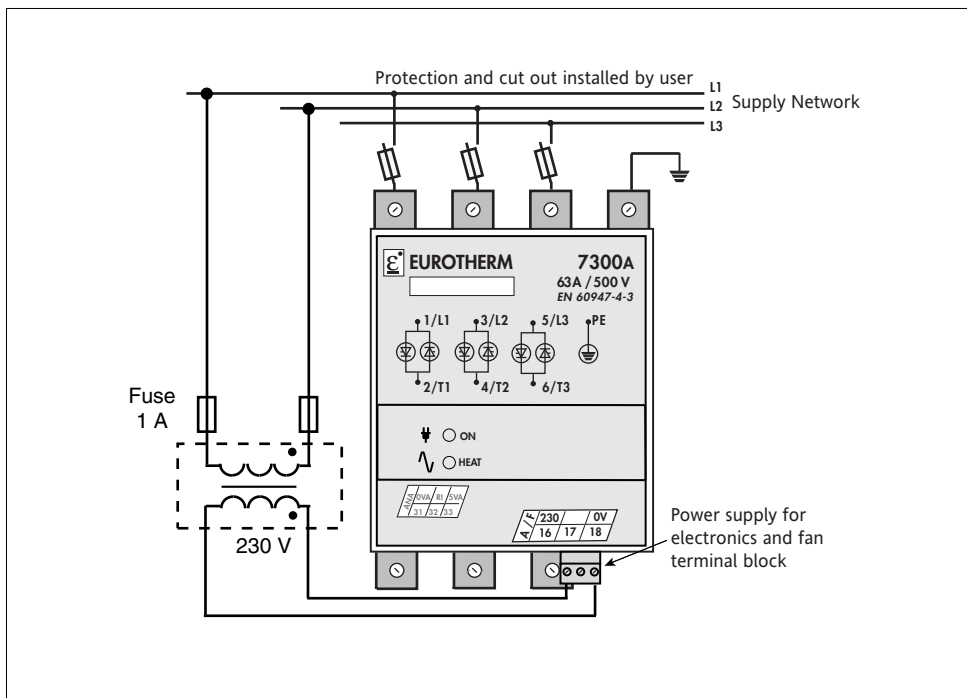

Figure 2-13 Wiring example for the external auxiliary power supply for electronics and the fan (code 230V)

### 2.5.6. Alarm relay contact (alarm option)

If one of the alarm options is fitted, an **alarm relay contact** is available on the ‘**ALR**’ terminal block (see figure 2-14).

The type of contact (closed or open on alarm) is determined by the product code.  
 Contact switching capacity: 0.25A (maximum 250Vac or 30Vdc).

**Important!**

The type of contact (closed or open on alarm) determines the terminal numbers in accordance with standard EN 60947-4-3 (as shown on figure 2-11).

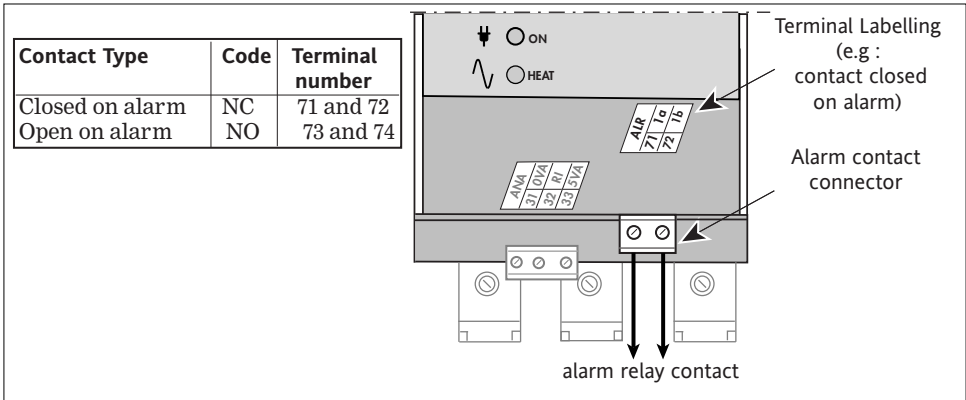

Figure 2-14 Typical alarm relay contact connections

## 2.5.7. Acknowledgement signal (ICO option)

With the ICO option, the alarms listed below may be acknowledged with a +5V signal applied to an **ACK** logic input (terminal 62) available on the '**DIG.IN**' terminal block.

- **Over-load**
- **Partial Load Failure**
- **Total Load Failure**

Alarms can be acknowledged in 2 ways:

- by connecting a contact between terminal **63**, labelled **5VD** (+5 V user output) and the **ACK** input (see figure 2-15a)
- by applying an **external 5V source** between terminals **0VD** and **ACK** (see figure 2-15b).

**Note:** The DLF alarm can also be reset with the '**CHK/SET**' push button.

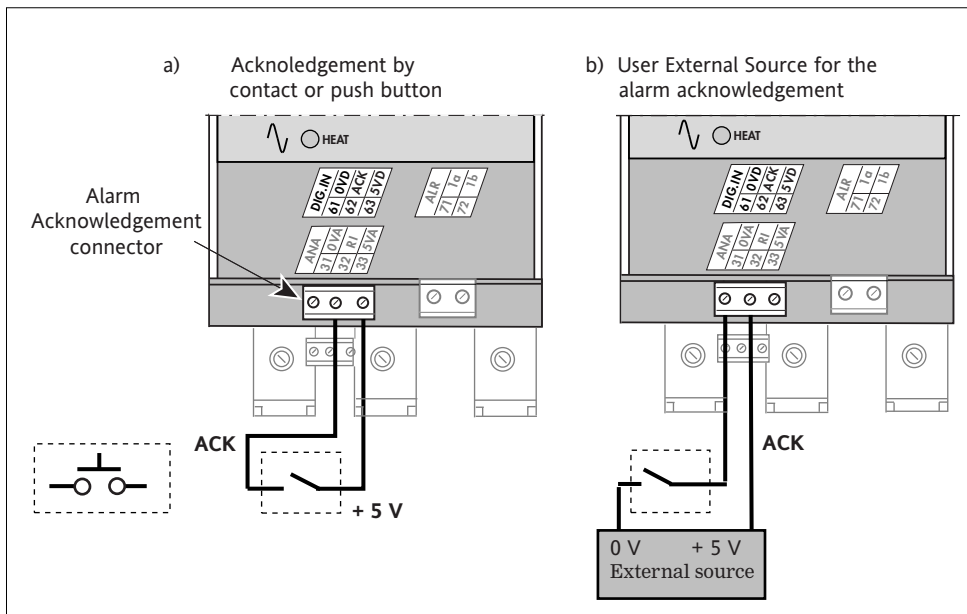

Figure 2-15 Typical external alarm acknowledgement contact connections

## 2.8. COMMUNICATION BUS CONNECTION

### 2.6.1. Polarity

By convention, the voltage on **line 'A'** of the bus, is **higher** than the voltage on **line 'B'** of the bus, when the RS485 line is active.

### 2.8.2. Wires screening

To guarantee reliable operation of the digital communication link, the bus must be connected using shielded **twisted pairs**.

#### Important!

- The shield of the communication cable must be connected to ground using the shortest possible connection at both ends.
- We recommend connecting the shielding to the DIN mounting rails as near as possible to the interface.

### 2.8.3. Termination resistors

The communication bus must have termination resistors fitted at each end:

- One line impedance matching resistor
- Two RS485 bus polarisation resistors

The interface as standard with the following internal resistors:

- **100kΩ** polarisation resistors,
- a **100kΩ** resistor between the 'A' and 'B' terminals

#### Important!

- To ensure correct operation, we recommend installing a matchig resistor typical value 220, on the last unit on the communication bus
- If the last unit on the bus is one of the 7000S series with digital communication, this resistor must be connected between terminals 'A' and 'B'

### 2.8.4. Power supply connection 'Aux2'

The digital communication option auxiliary power supply is **24Vac** or **24Vdc**  
The typical power consumption is **1.5VA**.

A 2 Amps slow blow fuse is required to protect the connection leads.

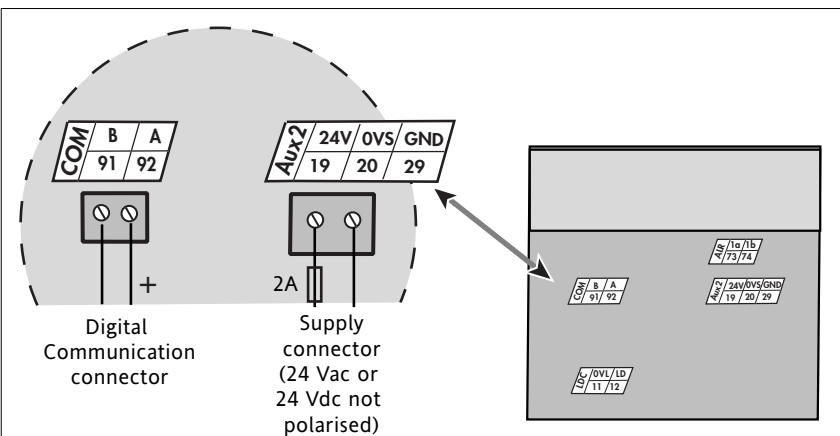

### 2.8.5. Digital communication wiring

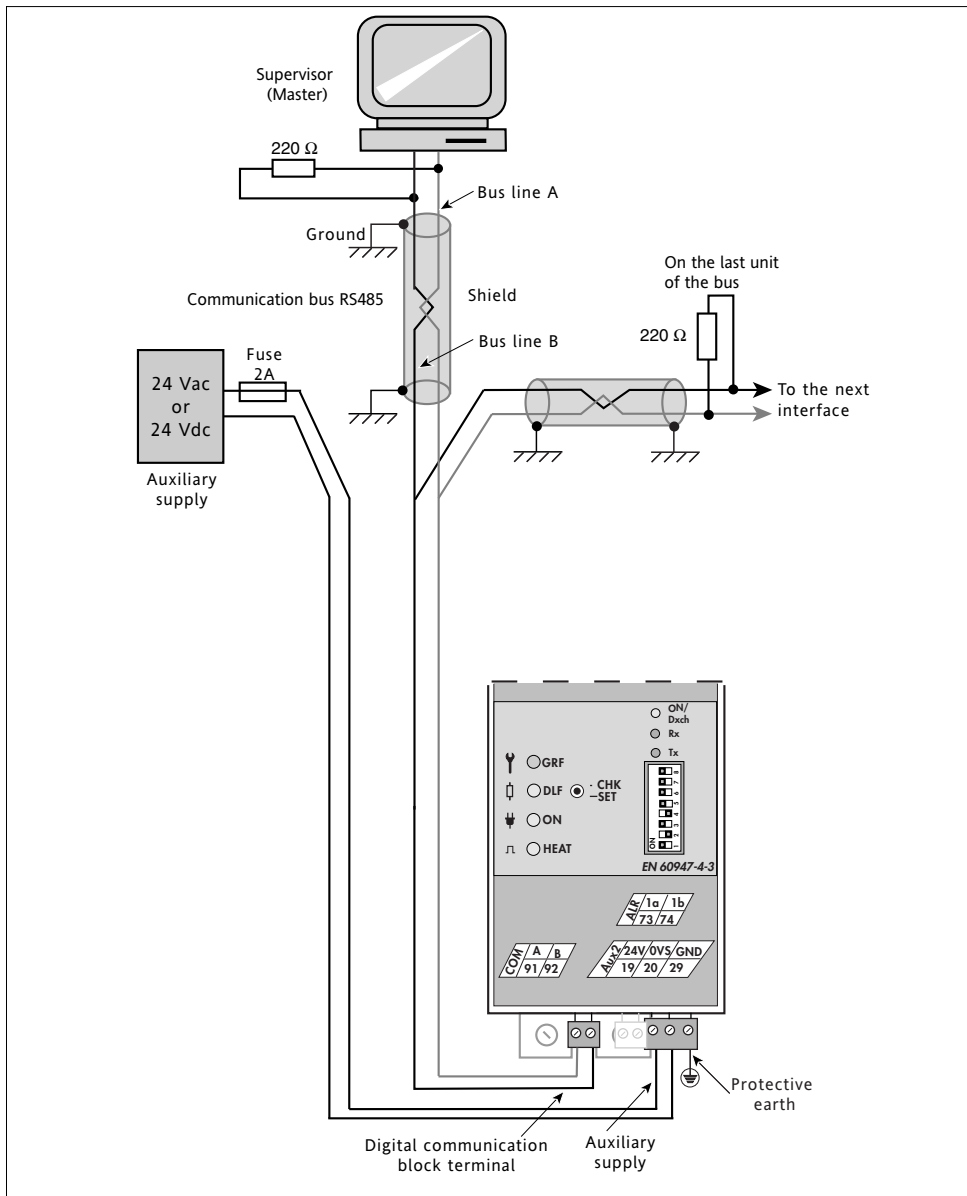

Figure 2-17 Digital communication wiring example



---

## Chapter 3

### FIRING MODES

Contents	Page
<b>3.1. General and firing mode signalling</b> .....	3-2
<b>3.2. Burst mode (codes C16 and C64)</b> .....	3-2
Firing delay (XFMR option) .....	3-3
<b>3.3. Single-cycle (code FC1)</b> .....	3-4
<b>3.4. Advanced single-cycle (code ASC)</b> .....	3-4
<b>3.5. Phase angle (code PA)</b> .....	3-5
<b>3.6. Safety ramp</b> .....	3-6
<b>3.6.1. Ramp on start-up</b> .....	3-6
<b>3.6.2. Magnetisation ramp (XFMR option)</b> .....	3-6

## 3. Chapter 3 - FIRING MODES

### 3.1. GENERAL AND FIRING MODE SIGNALLING

7300A power thyristor units can be controlled with one of the following thyristor firing types:

- thyristor firing angle variation ('Phase angle', code PA)
- a series of supply voltage cycles with zero crossing firing ('Burst mode', codes C16, C64, FC1, ASC)

Two indicators (green 'ON' and 'HEAT' LEDs) are included on the front panel in all versions, either basic or with options.

The indicators correspond to the thyristor firing mode as shown in the table below.

LED labelling	Signalling
	Power supply for electronics. Power supply fault (flashing). No reference Neutral (flashing).
	Thyristor firing request in 'Burst mode', 'Single-cycle' and 'Advanced single cycle' modes. Reminder: 'Advanced single-cycle' is only available with 4S and 6D three phase load configuration.
	Thyristor firing request in 'Phase angle' mode.

Table 3-1 Firing modes and base LEDs on front panel

During normal operation with zero-crossing switching, the 'HEAT' LED flashes to match the thyristor firing periods.

In normal operation in 'Phase angle' mode, the 'HEAT' LED varies in brightness depending on the firing angle, with maximum brightness during full firing.

### 3.2. BURST MODE (codes C16 and C64)

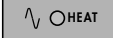
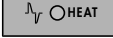
'Burst mode' firing is a **proportional cycle** which delivers a series of **whole supply cycles** to the load. Thyristor firing and cut-off is synchronised with the supply and occurs at **zero crossing**.

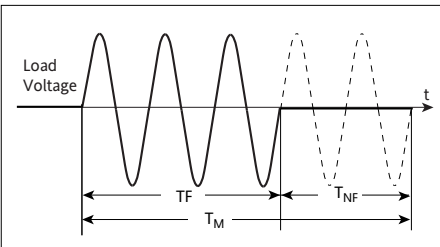

Figure 3-1 Thyristor firing for one of the phases, in 'Burst mode'

Thyristor firing in 'Burst mode' can be described by the firing time ( $T_F$ ), non-firing time ( $T_{NF}$ ) and modulation time ( $T_M$ ) where  $T_M = T_F + T_{NF}$  and the Base Cycle Time is equal to the **number of cycles** firing at **50%** of the duty ratio (or 50% of the power supplied to the load):  $T_B = T_F = T_{NF}$ .

The Base Cycle time is equal to **16 cycles** for code C16 and **64 cycles** for code C64.

## FIRING DELAY (XFMR option)

In 'Burst mode' firing with pure resistive loads, the thyristors are fired at zero voltage crossing to avoid sharp current rises.

For an **inductive load** (e.g. transformer primary), switching the thyristors at zero crossing generates transient over-currents (see figure 3-3a).

This transient could cause the high speed thyristor protection fuse to blow in certain cases.

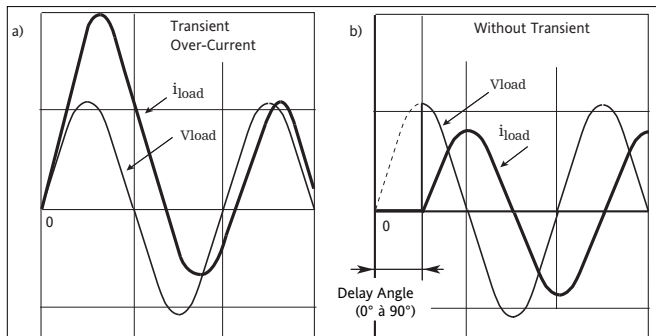
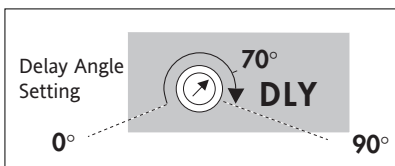

Figure 3-2 Typical switching with inductive load, at zero crossing (a) and with delay (b)



To avoid the over-current, the **first thyristor firing** must be **delayed** relative to the corresponding zero for each phase. The **delay** before thyristor firing starts may be adjusted with the 'DLY' potentiometer available with the **XFMR** option (C16 or C64 'Burst mode').

Figure 3-3 First firing delay adjustment potentiometer (XFMR option)

The 'DLY' potentiometer is a 3/4 turn type, and is used to set the delay angle for the first firing:

- from **0°** (turned anticlockwise to end stop)
- to **90°** (turned clockwise to end stop).

The factory setting for the first firing delay with the XFMR option is **70°** (typical value suitable for starting most applications).

The optimum firing angle can be adjusted with the 'DLY' potentiometer to match the **cos  $\phi$**  of the load to obtain a minimal transient over-current (using an oscilloscope).

### 3.3. SINGLE-CYCLE (code FC1)

'Burst mode' firing with a single firing or non-firing cycle is known as 'Single-cycle'.

For example, with a setpoint of 50% (corresponding to a duty ratio  $\eta = 50\%$ ) the modulation comprises 1 firing cycle and 1 non-firing cycle.

For duty ratios  $\eta < 50\%$  the **firing** time remains **unchanged** (1 cycle) and the non-firing time increases.

For duty ratios  $\eta > 50\%$  the **non-firing** time remains **unchanged** (1 cycle) and the firing time increases.

### 3.4. ADVANCED SINGLE-CYCLE (code ASC)

In order to **reduce power fluctuations** during firing time, 'Advanced single-cycle' thyristor firing mode uses:

- a whole number of **cycles** for firing, and
- a whole number of **half-cycles** for non-firing, and.

**Important:** 'Advanced single-cycle' firing mode is **only** available for **4S** or **6D** three-phase load configuration.

For duty ratios  $\eta < 50\%$ : - the thyristor firing time is **set to one cycle**  
- non-firing occurs for half-cycles.

For duty ratios  $\eta > 50\%$ : - the non-firing time is **set to half a cycle**,  
- firing occurs for whole cycles.

By using **half-cycles** for non-firing time, the modulation time is reduced compared with standard 'Single-cycle' mode, which is equivalent to burst mode with one cycle. 'Advanced Single Cycle' mode (Code ASC) **reduces flicker** on short wave infrared elements and is thus less annoying on the eyes.

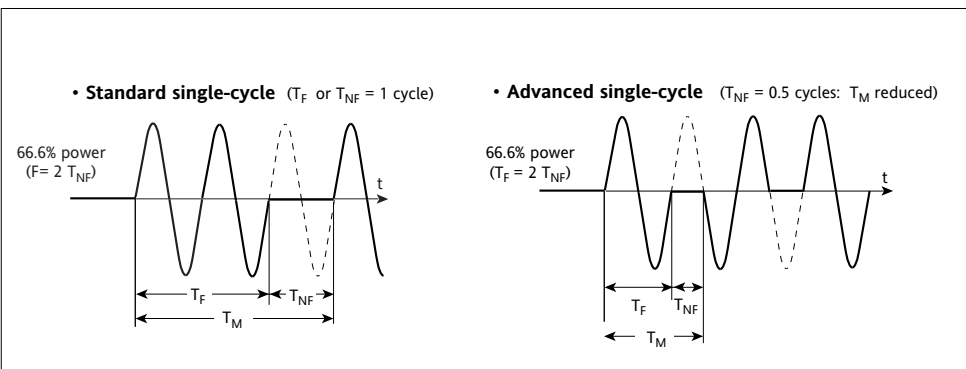

Figure 3-4 Example of Single-cycle and Advanced single-cycle firing mode

### 3.5. PHASE ANGLE (Code PA)

In 'Phase angle' mode the power delivered to the load is controlled by firing the transistors over a part of each supply half-cycle. Control involves varying the thyristor **opening angle** ( $\alpha$ ). The thyristor **firing angle** ( $\theta$ ) varies with the setpoint signal.

The load voltage ( $v_l$ ) and current ( $i_l$ ) depend on the three-phase load configuration.

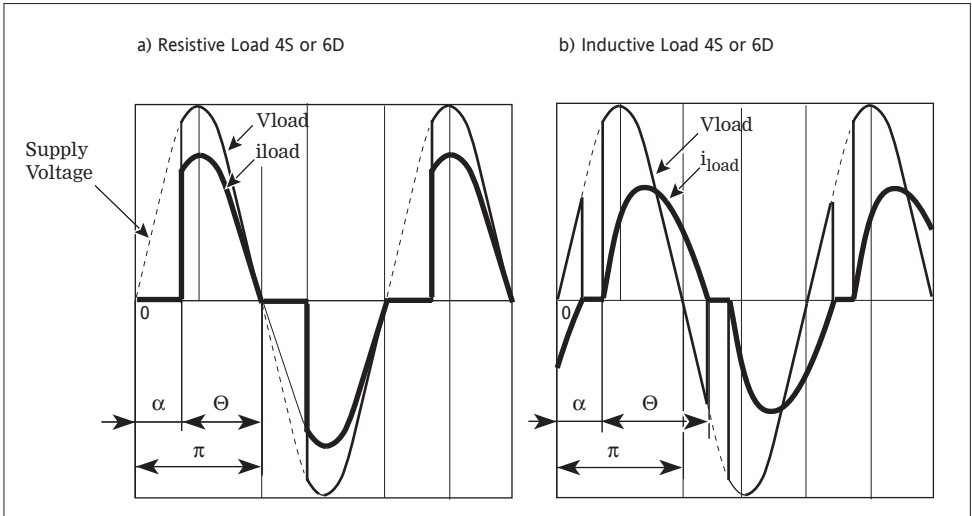

Figure 3-5 Voltage and current in one phase of a three-phase load (code 4S or 6D) in 'Phase angle' mode  
a) - resistive load; b) - inductive load.

### 3.6. SAFETY RAMP

The safety ramp involves progressively increasing the thyristor firing angle in order to apply the voltage (and current) to the load smoothly and thus reduce the start-up current of loads which have a low resistance when cold and inductive loads.

'Phase angle' mode allows the firing angle to be progressively varied on start-up, acting as a safety ramp.

#### 3.6.1. Start-up ramp

The start-up ramp is **active** in the following firing modes:

- 'Phase angle' (codes **V2CL** and **VICL + PA**)
- '16-cycle Burst mode' with current limit (codes **C16 + V2CL** or **VICL**).

The start-up ramp (approx. 16 cycles) is applied on the first firing after the thyristor unit is powered up and after the firing is cut for more than 5 seconds. The initial firing angle is approx. 6°.

After the ramp, the firing angle corresponds to the setpoint in 'Phase angle' mode;

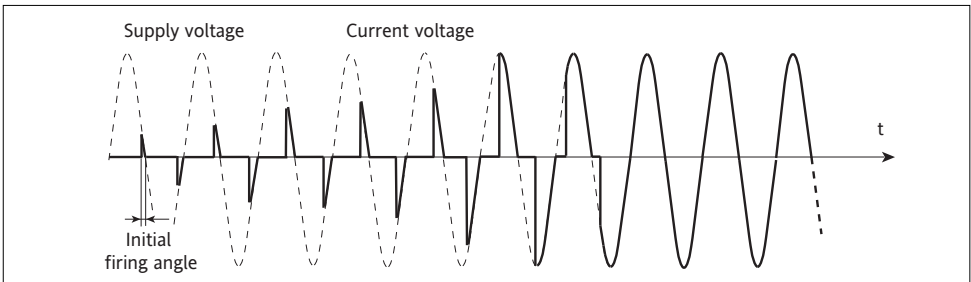

Figure 3-6 Start-up ramp (resistive loads)

#### 3.6.2. Magnetisation ramp (XFMR option)

For inductive loads, the safety ramp prepares initial magnetisation.

To avoid saturating transformers on power up, the safety ramp acts as a magnetisation ramp. With the XFMR option, after this ramp, the first 'burst mode' firing cycle starts with the first firing delay.

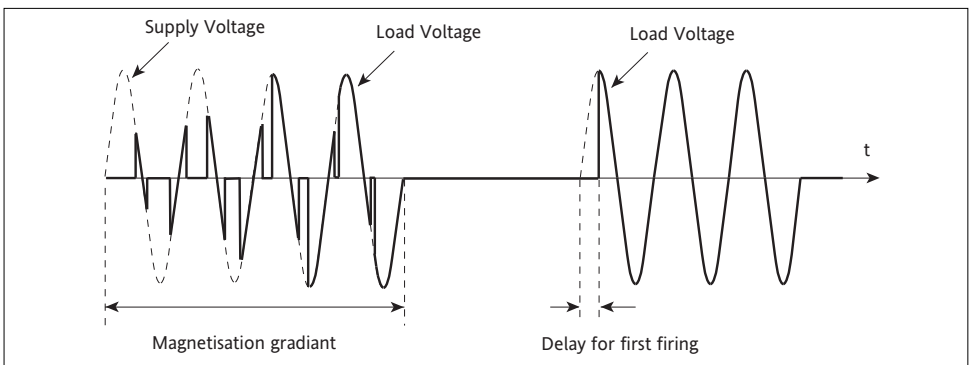

Figure 3-7 Transformer primary power-up in 'Burst mode' (XFMR option)  
Example: Star with neutral load configuration (code 4S)

---

## Chapter 4

### 4. CONTROL AND LIMITS

Contents	Page
4.1. Control .....	4-2
4.1.1. Control parameters .....	4-2
4.1.2. Input / Output ratio .....	4-2
4.2. Limitation adjustment (options) .....	4-3
4.2.1. Current recalibration (options without power control) ...	4-4
Settings .....	4-4
Settings with ICO option .....	4-4
4.2.3. Current and power limitation .....	4-5
4.3. Current and power specifications (options) .....	4-5

## 4. Chapter 4 - CONTROL AND LIMITS

### 4.1. CONTROL

#### 4.1.1. Control parameters

7300A power thyristor units use one of the following control parameters:

- rms load voltage squared  $V^2$
- rms load current squared  $I^2$
- power delivered to load  $P$
- Open Loop **OL**

The parameters are defined and explained in the table below:

Control Code	Definition
V2	Compensation of supply voltage variations
V2CL	Compensation of supply voltage variations with current limit
VICL	Power control with current and power limits
I2	Current squared control Only available with Phase Angle Mode (code PA)
OL	Open loop, no control. The output is the image of the setpoint Only available with Phase Angle Mode (code PA)

Tableau 4-1 Control parameter use

For the Base version (with no options) the **standard** control parameter is  $V^2$ .

The control parameter must be selected when ordering and forms part of the product code.

#### 4.1.2. INPUT / OUTPUT RATIO

The value of the control **parameter** is **proportional** to the analogue setpoint signal between 4% and 96% of the scale (see figure 4-1).

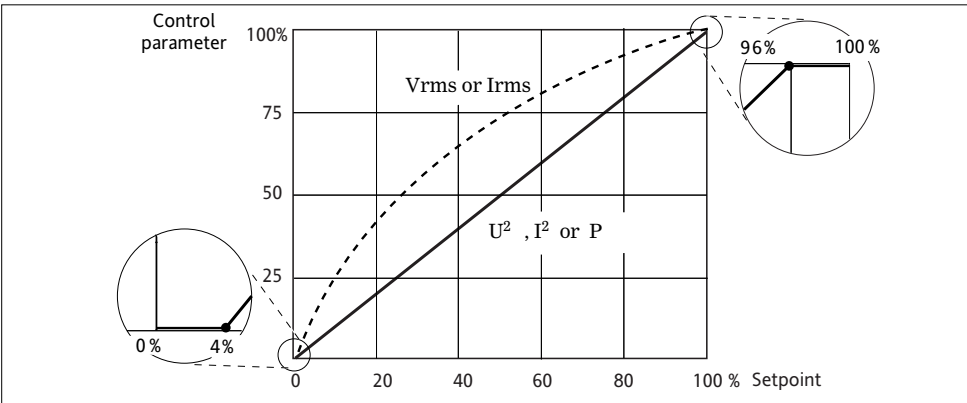

Figure 4-1 Ratio between control system input and output

The ratio between the setpoint and the control parameter ( $V^2$ ,  $I^2$  or  $P$ ) is **linear**.

Four types of input signal are available in the thyristor unit product codes:

0-20mA or 4-20 mA, 0-5V or 0-10V.

## 4.2. LIMITATIONS ADJUSTEMENT (options)

The thyristor units are factory-calibrated to their nominal value:  $I_N$  and  $P_N = V_N \cdot I_N$

The limits can be adjusted by adjusting the values with the 'I lim' (multi-turn) and 'VI lim' (3/4 turn) potentiometers on the front panel.

### 4.2.1. Current limitation (options without V-I control)

The 'I lim' potentiometer enables to limit the load current to a chosen value.

The active state of the current limitation is indicated by a green flashing LED 'Ilim'

The new current value  $I_{max}$  can be recalibrated between **20%** and **100%** of  $I_N$ .

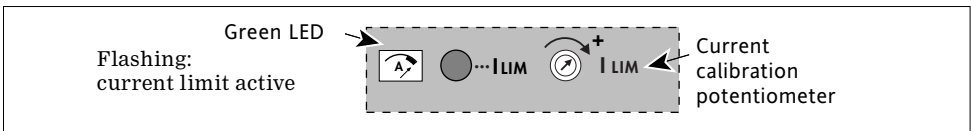

### Current setting

1. Turn the 'I lim' potentiometer fully round in the opposite direction to the arrow ( $I_{max} = 20\%$  of  $I_N$ ).
2. Set the thyristor unit firing with **100% setpoint**.
3. Measure the current value and use the 'I lim' potentiometer to set the desired value of  $I_{max}$  (new thyristor unit rating).

### Current setting with ICO option

In 'Burst mode' with the ICO option the 'I lim' potentiometer is used to set the over-load alarm (see page 5-8).

Over-load detection is signalled by flashing the red 'ICO' LED.

To adjust the setting:

1. Turn the 'I lim' potentiometer fully round in the direction of the arrow ( $I_{max} = 100\%$  of  $I_N$ ).
2. Set the thyristor unit firing with **100% setpoint**.
3. Rotate the 'I lim' potentiometer (**one turn at a time** at 5 second intervals) in the opposite direction to the arrow until the 'ICO' indicator starts flashing.
4. Rotate the potentiometer in the direction of the arrow by approx. **2 turns** and **acknowledge** the alarm (settings-calibration for the nominal load current used).

**Important:** If spurious alarms occur rotate the 'I lim' potentiometer in the direction of the arrow, **one turn at a time**, until the alarms cease.

## 4.2.2. Current and Power limitation

With the control option VICK, the following are available:

- 'I lim' current calibration potentiometer
- 'VI lim' power calibration potentiometer
- HRC calibration control signal on the 'ADJ.CAL' terminal block

Recalibration is possible:

- current  $I_{\max}$  from **20%** to **100%** of  $I_N$
- power  $P_{\max}$  from **50%** to **100%** of  $(V_N \cdot I_{\max})$ .

The HRC setting control signal ('ADJ.CAL' terminal block) can be used to aid setting with the 'I lim' and 'VI lim' potentiometers whether or not the thyristor unit is firing.

### Setting current and power limitation

The value of the DC voltage between terminals HRC (67) and 0VC (66) represents:

- The **image** of the maximum **current** ('VI lim' potentiometer fully turned in the direction of the arrow)
- The **image** of the maximum recalibrated **power** (1 V corresponds to **100%  $P_N$** ).

The control signal is equal to **1V** if calibrations are **nominal** ( $I_{\max} = I_N$  and  $P_{\max} = P_N$ ).

The minimum value of the signal is **0.1V** ( $I_{\max} = 20\%$  and 'VI lim' set to 50% of  $V_N \cdot I_{\max}$ ).

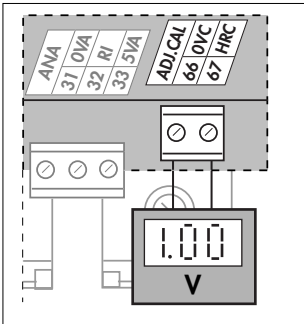

Setting:

1. Turn the 'VI lim' potentiometer fully round in the direction of the arrow (nominal power).
2. Use the 'I lim' potentiometer to set the  $I_{\max}$  value.
3. Use the 'VI lim' potentiometer to set the  $P_{\max}$  value. Check the resulting power setting on the HRC signal (accounting for  $I_{\max}$ ).

#### Important:

The current limitation must be done before adjusting the power limitation.

### 4.3. CURRENT AND POWER LIMIT SPECIFICATIONS

The table below summarises the operation of the limits used in the 7300A series power thyristor units.

Firing mode	Control type	Potentiometer		Operation of limit
		Name	Action	
C16	V2CL	I lim	Thyristor unit current recalibration: set threshold $I_{max}$	Current limit by threshold. If the maximum of the three currents $I_M > I_{max}$ : firing angle variation. V2 control in 'Burst mode 16'
	VICL	I lim	Thyristor unit current recalibration: set threshold $I_{max}$	Current limit by threshold. If the maximum of the three currents $I_M > I_{max}$ : firing angle variation. P control in 'Burst mode 16'
		VI lim	Power limitation: set ratio between P and setpoint	Power limit by control in 'Burst mode 16' taking $P_{max}$ into account
PA	V2CL	I lim	Thyristor unit current recalibration: set ratio between I (%) and setpoint	Current limit by transfer. If the mean of the 3 currents squared $I_M^2 > V^2$ (%): automatic transfer to $I^2$ control by firing angle variation.
	VICL	I lim	Thyristor unit current recalibration: set ratio between I (%) and setpoint	Current limit by transfer. If the mean of the 3 currents squared $I^2 > V^2$ (%): automatic transfer to $I^2$ control by firing angle variation.
		VI lim	Power limitation: set ratio between P and setpoint	Power limit by control (variation of firing angle; new ratio between P and setpoint. Setpoint Relinearisation
	$I^2$	I lim	Thyristor unit current recalibration: set ratio between I (%) and setpoint	$I^2$ Control

Table 4-2 Operation of current and power limits

**NOTE:**

$I^2$  current Control and Limitation operating condifiotns:

**1 - Standard**

If the gap between of the three currents squared is less than 25% of the calibrated nominal current  $I_N^2$ , then the control is achived at the mean value of the three currents squared.

$$\Delta I_i^2 < 25\% I_N^2 \text{ then } I^2 = (I1^2+I2^2+I3^2)/3$$

$i = 1,2,3$

**2 - In the case of an unbalanced load.**

If the gap is more than 25%, then the control is achieved at the squared value of the highest current value.

$$\Delta I_i^2 > 25\% I_N^2 \text{ then } I^2 = I_{\max}^2$$

$i = 1,2,3$

# Chapter 5

## ALARMS

Contents	Page
<b>Alarm diagnostic summary</b> .....	5-2
<b>5.1. Safety mechanisms</b> .....	5-3
<b>5.2. Alarm strategy</b> .....	5-3
<b>5.2.1. Firing cut-off</b> .....	5-3
<b>5.2.2. Alarm priority</b> .....	5-3
<b>5.2.3. Memorisation</b> .....	5-3
<b>5.3. Load Monitoring</b> .....	5-4
<b>5.3.1. Setting the DLF alarm</b> .....	5-5
<b>5.3.2. PLF or TLF detection</b> .....	5-5
<b>5.3.3. PLF detection sensitivity</b> .....	5-5
<b>5.4. Signalling of channel for load fault</b> .....	5-5
<b>5.5. Load type matching</b> .....	5-5
<b>5.6. Disabling alarms for load failure signalling</b> .....	5-5
<b>5.7. Functions of DLF alarm push button</b> .....	5-6
<b>5.7.1. Setting Request</b> .....	5-6
<b>5.7.2. Diagnostic</b> .....	5-6
<b>5.7.3. Disabling</b> .....	5-6
<b>5.8. Over Load Alarm</b> .....	5-7
<b>5.8.1. Availability</b> .....	5-7
<b>5.8.2. Alarm conditions</b> .....	5-7
<b>5.8.3. Alarm Actions, Memorisation, Acknowledgement</b> ..	5-7
<b>5.9. Standard alarms</b> .....	5-8
<b>5.9.1. Faults detected</b> .....	5-8
<b>5.9.1.1. Availability</b> .....	5-8
<b>5.9.1.2. Alarm actions</b> .....	5-8
<b>5.9.1.3. Memorisation</b> .....	5-8

## ALARM DIAGNOSTIC SUMMARY

The table below summarises all status LED information needed to **diagnose the fault**.

OPTIONS ▶	Basic version and all options	ICO	ICO GRF DLF	GRF	DLF				
<b>LEDs (Front panel)</b> ▼									
-T° ...ICO <i>Red</i>			$\geq 125\text{ A}$						
GRF <i>Red</i>									
DLF <i>Orange</i>									
ON <i>Green</i>									
HEAT <i>Green</i> or									
HEAT <i>Green</i>									
<b>DIAGNOSIS:</b>	↓ No alarm Firing: Zero crossing or Phase angle	↓ Supply fault Firing stopped	↓ Over- current Firing stopped	↓ Neutral lost Firing stopped	↓ Over- heating Firing stopped	↓ Thyristor short circuit or Total Load Failure	↓ Thyristor short circuit	↓ Total Load Failure	↓ Partial Load Failure

Table 5-1 Diagnosing operation and alarms according to front panel LED status

## Chapter 5 - ALARMS (Options)

### 5.1. SAFETY MECHANISMS

The alarms on the 7300A protect the thyristors and the load against certain types of abnormal operation and provide the user with information about the type of fault.



**Danger**

- Alarms are not under any circumstances a replacement for personnel protection.
- The user is responsible for installing independent safety mechanisms which must be inspected regularly. Given the value of the equipment controlled by the 7300A, this is strongly recommended.

Eurotherm can supply various types of suitable alarm detector.

### 5.2. ALARM STRATEGY

- **Load monitoring** (option): monitoring of load and thyristors
- **Over Load Alarm** (option): protection against exceeding a current threshold
- **Standard Alarm**: supply fault, neutral cut-off and over heating for units 125A.

#### 5.2.1. Conduction inhibited

The detection of the following default:

- **‘Over-Load’**
- **‘Overheating’** (for current ratings 125A only)
- **‘Supply voltage’** or **‘Loss of neutral’**
- **‘Frequency out of range’**

**Stops** the thyristor conduction (even if the control signal is present)

#### 5.2.2. Alarm priority

Only one alarm is signalled if several faults occur simultaneously. Over load and standard alarms, thermal faults and thyristor short-circuits **take priority** over load fault.

#### 5.2.3. Memorisation

Load monitoring and standard alarms are **not memorised**.

After an alarm has been detected, and once the fault conditions have cleared, signalling for these alarms (LED and relay) returns to the non-alarm position.

**Over-current alarms and Neutral cut-off are memorised** and must be acknowledged

Thyristor short-circuit and neutral cut-off require repairs.

### 5.3. LOAD MONITORING

Two diagnostic options are available:

- GRF option (Gross Fault) which permits to detect the following serious faults:
  - Total Load Failure: TLF
  - Thyristor Short-Circuit: THSC
  - Over Heating: T° (for units 125A only)
- DLF option (Diagnostic Load Failure), presents the same fault detection as GRF option with in addition, the Partial Load Failure detection (PLF).

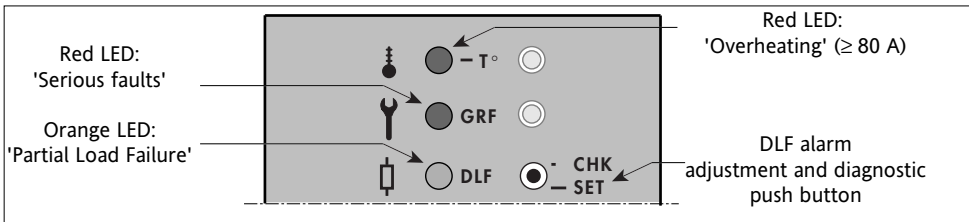

Figure 5-1 Layout of front panel LEDs with 'GRF' and/or 'DLF' option

Fault	LED State				Firing stopped	Typical reaction type
	'T°' red	'GRF' red	'DLF' orange	'HEAT' green		
Partial Load Failure (PLF)	OFF	OFF	Flashing	ON or Flashing	No	5 s to 13 s
Total Load Failure (TLF)	OFF	ON	Flashing			
Thyristor Short-Circuit (THSC)	OFF	ON	OFF			
Over-temperature (T°)	ON	OFF	OFF	OFF	Yes	

Table 5-1 LEDs for serious alarms or faults with 'GRF'and/or 'DLF' options

- Note:**
- Thermal faults are **signalled** by the 'T°' LED if one of the alarm options or one of the control options (except V2 and OL) is fitted. The unit is **protected** against thermal faults whether or not they are signalled. Thermal faults are signalled by the alarm relay **if** one of the alarm options is fitted.
  - The DLF LED **flashes** in particular ways to indicate the **number** of the controlled channel (of the three thyristor channels) on which load failure (TLF or PLF) has occurred.

### 5.3.1. Setting the DLF alarm

This can be set using the push button on the front panel. The PLF detection setting can only be adjusted (reference impedance recalculated) in the following conditions:

- rms voltage across load is greater than **40%** of the nominal voltage
- rms current is greater than **30%** of the rated current
- no over-temperature or thyristor short-circuit faults.
- each time PLF setting is required the three-phase load must be balanced.
- in order to guarantee the full scale sensitivity, settings must be done at the load's nominal temperature

Note: PLF settings stay memorised even if a supply cut-out occurred

### 5.3.2. Partial or Total Load Failure Detection

PLF detection is only possible under the following conditions:

- no over-temperature or thyristor short-circuit faults.
- rms voltage across the load greater than **40%** of the nominal voltage and,
- rms load current greater than **5%** of the rated current.

**Total Load Failure TLF** monitoring is only possible under the following conditions:

- no over-temperature or thyristor short-circuit faults.
- the rms voltage across load is greater than **40%** of the nominal voltage

### 5.3.3. Partial Load Failure Detection Sensitivity

Partial Load Failure Detection Sensitivity can be expressed in terms of a **maximum number** of load elements connected in parallel for which the unit can detect the failure of one element. The DLF sensitivity guaranteed for identical three-phase loads connected in parallel is:

3D coupling - 1 element out of 3

3S, 4S and 6D coupling - 1 element out of 4

## 5.4. SIGNALLING OF CHANNEL FOR LOAD FAULT

With the '**DLF**' option the DLF LED **flashes** in particular ways to indicate the **number** of the controlled channel (of the three thyristor channels) on which load failure (TLF or PLF) has occurred.

## 5.5. LOAD TYPE MATCHING

PLF detection is **adapted** to the load type.

The type of load controlled is selected when ordering, with the product code:

- **LTCL** (Low Temperature Coefficient Load), or
- **SWIR** (Short Wave InfraRed elements).

## 5.6. DISABLING ALARMS FOR LOAD FAILURE SIGNALLING

**PLF** fault signalling ('DLF' indicator and relay) can be temporarily **excluded** from alarms by pressing the '**CHK / SET**' (**C**heck / **S**etting) push button.

If the fault persists, DLF signalling returns to the alarm position.

If the **ICO** option is used, PLF and TLF faults can be **excluded** from alarms using the external acknowledgement logic input.

## 5.7. FUNCTIONS OF DLF ALARM PUSH BUTTON

The push button on the front panel of the unit with the 'DLF' option is labelled 'CHK / SET' (Checking / Setting).

Pushing this push button as shown on the diagrams below sets and diagnoses the status of the PLF detection circuit.

### 5.7.1. Setting request

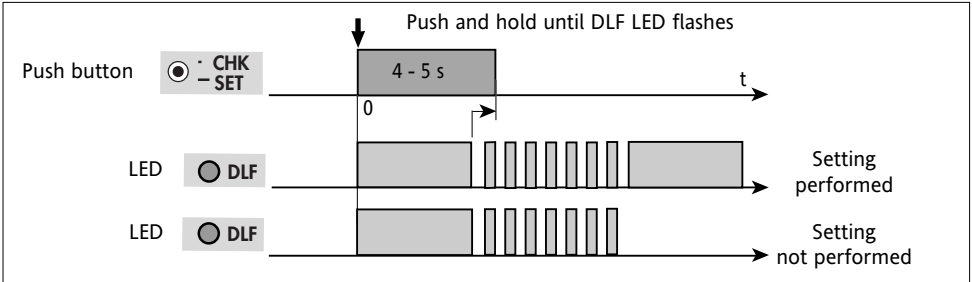

Figure 5-2a PLF detection setting request

### 5.7.2. Diagnostic

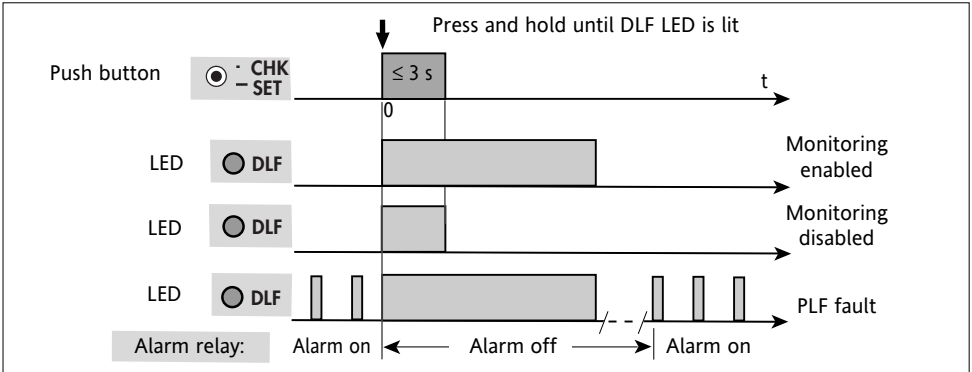

Figure 5-2b PLF monitoring diagnosis

### 5.7.3. Disabling

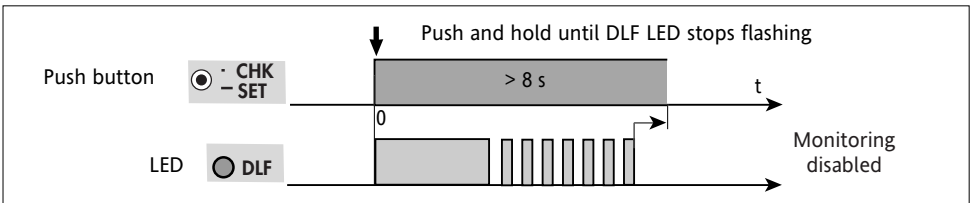

Figure 5-2c Disabling PLF monitoring

## 5.8. OVER LOAD ALARM (ICO option)

The type 2 alarm (**Over-current** alarm) monitors the maximum current value. This alarm (and option) is known as **ICO (Intelligent Chop Off)**.

### 5.8.1. Availability

The ICO option is available in **zero-crossing** firing modes ('Burst mode' and 'Single-cycle') provided the **DLF** option is fitted.

The ICO option is not available for short wave infrared elements and transformers (code SWIR or XFMR), or in control with current limit (code VICL or V2CL).

### 5.8.2. Alarm conditions

With the ICO option an **Over load** fault is detected if one of the following two conditions occurs:

- the **instantaneous** current on one of the three phases exceeds a threshold of **150%** of the instantaneous rated current
- the **rms** load current (over 5 consecutive seconds) on one of the three phases exceeds a threshold of 110% of the recalibrated rms current.

The instantaneous or rms current threshold can be adjusted with the '**I lim**' potentiometer during the current calibration phase, from 20% to 100% of the nominal current for the thyristor unit.

### 5.8.3. Alarm Actions, Memorisation, Acknowledgement

If an over-current alarm is triggered, thyristor firing **stops**:

- at the end of the half-cycle when the instantaneous current threshold is exceeded
- after approx. 5 s of continuously exceeding the rms current threshold.

Over-current alarm cut-off is signalled as follows:

- the position of the Alarm relay **contact** changes
- the '**...ICO**' LED **flashes** (and turns red).

Important:

- The 'ICO' LED starts flashing as soon as the rms current **exceeds** the threshold; i.e. **5 s before** firing may be cut off.
- **Setting** the Over-current alarm threshold in operating conditions is described on **page 4-4**.

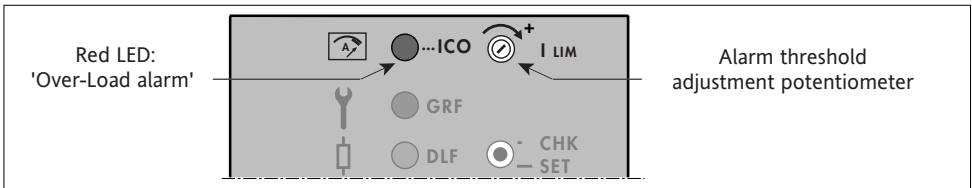

Figure 5-3 Layout of the 'ICO' LED and 'I lim' potentiometer with the ICO option

The over-load alarm cut-off is **memorised**.

The thyristor unit remains cut off and signals the alarm status.

The Over-load alarm may be **acknowledged** by applying +5V to the '**ACK**' terminal on the '**DIG.IN**' terminal block (logic signal inputs). The internal supply ('**5VD**' terminal) or an external source may be used to acknowledge the alarm remotely.

## 5.9. STANDARD ALARMS

### 5.9.1. Faults detected

These alarms monitor the following faults:

- supply voltage absent on one or several phases.
- supply frequency outside operating limits
- neutral reference voltage absent (in Star with neutral configuration, code 4S).
- Over Heating (for units 125A)

The supply voltage absent alarm may be caused by supply network faults, blown thyristor or supply protection fuses, open circuit breakers or line contactors.

The neutral reference voltage absent alarm may be caused by loss of the link to terminal **21** ('EXT' terminal block: external reference voltage) or by a blown **fuse** in the connection to the supply neutral (see figure 2-9).

#### 5.9.1.1. Availability

Supply fault monitoring (voltage absent or frequency out of range) is fitted as standard to all 7300A thyristor units, including Base version units.

The neutral reference voltage is automatically monitored under the following conditions:

- Star with neutral load configuration (code **4S**) is used, and
- the **DLF** or/and power control (code **VICL**) options are selected.

#### 5.9.1.2. Alarm actions

If an alarm is detected, thyristor firing is **cut off**:

- at the end of the half cycle for a supply fault
- after approx. 5 s of integration for loss of reference neutral.

Alarms are signalled by:

- the position of the Alarm relay **contact** changes  
(the relay is only fitted if one of the alarm options is selected)
- the green '**ON**' LED flashes.

Also, if an alarm option is fitted, loss of reference neutral is indicated by the red '**GRF**' LED lit steadily.

#### **Important!**

If the supply voltages upline from the thyristor unit are **absent** and the internal auxiliary supply option is used (code '**SELF**') all LEDs on the unit will be unlit.

#### 5.9.1.3. Memorisation

**Supply Fault alarms** (voltage or frequency) are **not memorised**.

The indicators for faults detected return to **normal** ('ON' LED and relays in non-alarm position) after the fault condition ceases.

If the reference neutral voltage connection is **lost**, the installation needs to be repaired and the unit is therefore switched off. It is however possible to **acknowledge** this alarm using the '**ACK**' input with the '**ICO**' option.

## Chapter 6

### 6. DIGITAL COMMUNICATION

Contents	Page
<b>6.1. General</b> .....	6-2
<b>6.1.1. Exchange Type</b> .....	6-2
<b>6.1.2. Communication protocol</b> .....	6-2
<b>6.1.3. Transmission</b> .....	6-2
<b>6.1.4. Parameters Status</b> .....	6-2
<b>6.1.5. Power Failure</b> .....	6-2
<b>6.2. Configuring the Physical address and speed</b> .....	6-3
<b>6.2.1. Physical address</b> .....	6-3
<b>6.2.2. Transmission speed</b> .....	6-3
<b>6.2.3. Addressing by message broadcasting</b> .....	6-4
<b>6.3. Diagnostic LEDs</b> .....	6-4
<b>6.4. Error Code</b> .....	6-4
<b>6.5. Digital Communication Parameters</b> .....	6-5
<b>6.6. Remarks</b> .....	6-10

## Chapter 6 - DIGITAL COMMUNICATION

### 6.1. GENERAL

Digital communication option can:

- control 7300A thyristo units
- monitor all operating parameters via the Supervisor.

#### 6.1.1. Exchange type

Message are exchanged in 'Master/Slave' mode.

The digital communication option always operates as a slave, with the supervision system or PLC as Master. All exchange comprise a request from the Master and an answer from the slave (except in broadcast mode).

#### 6.1.2. Communication protocol

The Modbus RTU communication protocol is used.

Communication complies with the specifications given in 'GOULD MODICON Protocol Reference Guide PI-MBUS-300 rev J'.

#### 6.1.3. Transmission

Transmission standard: **RS485**, 2 wires. The transmission frame uses binary characters.

Format of each character:

- 1 start bit
- 8 data bits
- 1 stop bit

**Transmission is asynchronous.**

Two transmission speeds are available: **9.6** or **19.2** kbaud.

The speed can only be selected by the microswitch SW8 on the interface.

#### 6.1.4. Parameters status

The status of a parameter may be Read, Read and Write or Memorised Read/Write:

- **Read only** parameters are labelled '**R**'
- **Read and Write** parameters are labelled '**R/W**'
- **Memorised Read and Write** parameters are labelled '**R/W/M**'

#### 6.1.5. Power failure

If the power supply 'AUX2' fails, the interface stops communicating and the output is set to zero.

When power is restored, the interface enters 'waiting for communication' state.

## 6.2. CONFIGURING THE PHYSICAL ADDRESS AND SPEED

In order to design the power unit and the different parameters, the Modbus protocols:

- The 7000 series unit **Physical** address on the communication bus.
- The **parameter** addresses which determine the parameter required.

**Important:** The physical address is configured by microswitches on the front panel of the unit, and cannot be chosen or changed using digital communication.

Configuring the digital communication involves selecting:

- The **physical Interface address** communication the communication bus
- The transmission **speed**.

### 6.2.1. Physical interface address

The interface address on the communication bus is set by switches **SW1** (LSB bit 0) to **SW7** (MSB bit 6). The address may be set between 1 to 127.

**Example:** Switch positions to set the unit's address to **74** (**1001010** binary in 7 bits )

Address 74 in binary, 7 bits	1	0	0	1	0	1	0
Switch position	On	Off	Off	On	Off	On	Off
Switch number SW	7	6	5	4	3	2	1

MSB

LSB

### 6.2.2. Transmission speed

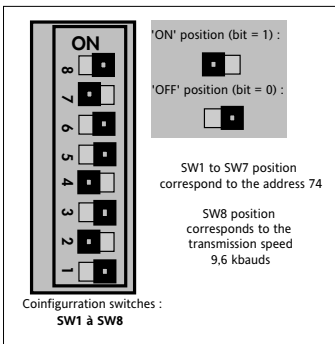

The transmission speed is determined by switch **SW8**:

- the '**OFF**' position corresponds to a speed of **9.6** kbaud
- the '**ON**' position corresponds to a speed of **19.2** kbaud

**Important:** The factory default settings are for an address of 32 and the transmission speed corresponding to the product code.

Figure 6-1 Example: Switch positions.

### 6.2.3. Addressing by message broadcasting

**00 address** is reserved for the message diffusion to all the units connected to the bus. In this case, all the Slaves carry out the order but none will answer. Writing diffusion is available on every parameters with the 'Read and Write' status.

**Important!**



User is responsible for ensuring that a write command broadcast does not affect the operation of other units on the same communication bus. In a program loop, the Writing of a parameter which is saved in permanent memory must not be included

### 6.3. DIAGNOSTIC LEDs

Three LEDs on the front panel show the interface status

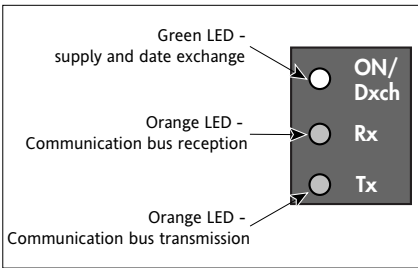

Figure 6-2 Interface status diagnostic LEDs

#### Green 'ON/Dxch' diagnostic LED

Initialisation phase on power up	Waiting for frame Master	Communication established
Flashes 5 times: 400 ms on - 400 ms off	Flashes at @ 0.5 Hz 1 s on / 1 s off	Lit standily

Table 6-1 operation of green 'ON/Dxch' LED

**Important:**

If 00 address (reserved for broadcast) is selected by mistake, the interface remains in the initialisation phase

#### Orange 'Rx' LED

Linked to data received, and flashes as requests are sent by the master.

**Important:**

If the 'Rx' LED is lit steadily, the polarity of the communication signals may be inverted

#### Orange 'Tx' LED

linked to data sent, and flashes as responses are sent by the Slave.

### 6.4. ERROR CODES

If the interface detects an error in the frame received, it returns an error code:

Error Code (decimal)	Error type
1	Prohibited function
2	Prohibited parameter address (unauthorised code sent)
3	Internal link failure (if present)
4	Prohibited data value
9	No data in request
10	Too much data in request

Table 6-2 Meaning of communication error codes

## 6.5. DIGITAL COMMUNICATION PARAMETERS

### PARAMETERS

The following parameters are at fixed addresses allowing the Master Modbus in order to obtain data from the slave whatever power units from the 7000 range is used with the digital communication option.

Abbreviation	Parameters name	Decimal Address	Status	Format / Measure
SL	Setpoint Local	01	R/W	0-255 (0-100%)
FS	Fast Setpoint transfer	02	R/W	0-255 (0-100%)
HS	High Setpoint Limit	16	R/W/M	0-255 (0-100%)
CL	Current Limit	17	R/W/M	0-255 (0-100%)
OS	Optional Status Word	18	R/W/M	HEX
SW	Status Word	32	R	HEX
XS	eXtended Status Word	33	R	HEX
OP	Output Power	34	R	0-255 (0-100%)
PV	Process Value	35	R	0-255 (0-125%)
SP	Working Setpoint	36	R	0-255 (0-100%)
PW	Power	37	R	0-255 (0-125%)
VV	Voltage Value	38	R	0-255 (0-125%)
C1	Current value channel 1	39	R	0-255 (0-125%)
C2	Current value channel 2	40	R	0-255 (0-125%)
C3	Current value channel 3	41	R	0-255 (0-125%)
CV	Current Value	42	R	0-255 (0-100%)
RI	Remote Input	43	R	0-255 (0-100%)
LL	Local Limit	44	R	51-255 (0-100%)
LS	Limit Setpoint	45	R	0-255 (0-100%)
HL	High Local limit	46	R	0-255 (0-100%)
DT	Delay Triggerring	47	R	0-90 (0-100%)
MI	Manufacturer Identifier	<b>65280</b>	R	ASCII
CW	Command Word	<b>65488</b>	R/W	0 - 7
GSW	General Status Word	<b>65504</b>	R	HEX
SN	Serial Number	<b>65520</b>	R	HEX
V0	Version 0	<b>65522</b>	R	HEX
V1	Version 1	<b>65526</b>	R	HEX
DI	Device Identifier	<b>65528</b>	R	0-65535
MF	Modbus Function	<b>65529</b>	R	HEX
CTO	Comm Time Out	<b>65531</b>	R/W/M	0-65535
STO	Setpoint Time Out	<b>65532</b>	R/W/M	0-255

## PARAMETERS DESCRIPTION

### SL - Setpoint Local:

Corresponds to the value required for the internal regulation loop of the unit.  
 Authorised value between 0 and 255.

### FS - Fast Setpoint Transfer:

Used to store prepared in advance setpoints in live memory.  
 The setpoint is transferred to the active setpoint (address 01) by sending code 05 in the command word.

### HS - High Setpoint Limit:

Sets the maximum value of the digital setpoint.  
 Authorised value between 0 and 255, stored in permanent memory.

### CL - Current Limit:

Allows nominal current calibration.  
 This recalibration (LS parameter) is equal to the product between the digital current (CL parameter) and the front panel current limitation (Ilim, LL parameter).  
 Authorised value between 0 and 255, stored in permanent memory.  
 Only writable for units with the U\*I option.

### OS - Optional Status word:

This parameter allows the modification of some of the product configuration bit, at the same time and without using the Command Word CW and its codes.  
 Parameter stored in permanent memory.

Note: If the configuration loaded using the Optional Status Word OS, is not available, the only way to verify the effective result, is to read the Status Word SW.

Bit to bit definition:

Bit Number	Configuring status word for a basic unit	
0	Setpoint after time-out exceeded	0: analogue 1: digital
1	Working setpoint	0: analogue 1: digital
2 to 4	Not used	
5	Firing Mode	000: PA, 001: FC1, 010: FC16, 011: C64
6		100: SCA, 101: reserved
7		110: HC16, 111: reserved
8	Control Mode	000: U*U, 001: U*U ↔ I*I (PA only)
9		010: I*I (PA only), 011: reserved
10		100: U*I ↔ I*I, 101: reserved, 110: Open Loop, 111: reserved
11 to 15	Not used	

**SW - Status Word:**

Bit to bit status definition of the unit.

Bit Number	Configuration Status word for the SW parameter
0 to 3	Reserved. Product configuration
4	Limitation mode: '0': in Phase Angle '1': by conduction inhibition
5	000: PA, 001: FC1, 010: FC16, 011: C64,
6	100: SCA, 101: reserved,
7	110: HC16, 111: reserved
8	000: U*U, 001: U*U ↔ I*I (PA only),
9	010: I*I (PA only), 011: U*I, 100: U*I ↔ I*I,
10	101: reserved, 110: Open Loop, 111: reserved
11	Load type: Resistive or inductive
12	Load type for DLF detection '0': LCTL '1': SWIR
13	reserved
14	00: star configuration (3S), 01: Star with neutral (4S)
15	10: Delta configuration (3D), 11: Open Delta (6D)

**XS - eXtended Status Word:**

Bit to bit alarm status

Bit Number	State	Configuration Status word for the XS parameter
0	'1'	GRF fault (TLF and THSC)
1	'1'	PLF and TLF fault channel 1
2	'1'	PLF and TLF fault channel 2
3	'1'	PLF and TLF fault channel 3
4	'1'	PLF setting state ('1': set)
5	'1'	Current limitation using PA Active
6		Reserved
7		Reserved
8	'1'	Supply fault (Phase missing or frequency fault)
9	'1'	Unit disabled / Allowed by digital communication
10	'1'	Thermic fault
11	'1'	Short circuit thyristor fault
12	'1'	Over Load fault
13	'1'	Reserved Neutral failure in 4S configuration
14		Reserved
15		Reserved

**OP - Output Power Request:**

Corresponds to the duty ratio value in bust firing mode or to the conduction angle in phase angle firing mode.

Read value between 0 and 255.

**PV - Process Value:**

Represents the selected parameter value for the regulation system.

Read value between 0 and 255.

**SP - Working Setpoint:**

Corresponds to result of the product between the setpoint local and the setpoint limit

with Bit 1 OS = 1  $SP = (SL * HS)/255$  (Read value between 0 and 255)

or

is the result of the product between the remote input and the high local limit

with Bit 1 OS = 0  $SP = (RI * HL)/255$  (Read value between 0 and 255)

**PW - Power:**

Corresponds to the output power of the power thyristor unit after possible recalibration.

Only present if U\*I option chosen. Read value between 0 and 255.

**VV - Voltage value:** Read value between 0 and 255.

**C1 - Current Value Channel 1:** Read value between 0 and 255.

**C2 - Current Value Channel 2:** Read value between 0 and 255.

**C3 - Current Value Channel 3:** Read value between 0 and 255.

**CV - Current Value:**

Mean value of the three currents:  $CV = (C1+C2+C3)/3$

Read value between 0 and 255

**RI - Remote Input:** Read value between 0 and 255

**LL - Local Limit:**

Value of the potentiometer (Ilim) on front panel.

**LS - Limit Setpoint:**

Represents the current recalibration. Corresponds to the result of the product between the digital current limit (CL) and the local limit (LL):  $LS = (CL \times LL)/255$

Recalibration cannot be less than 20% of the nominal current of the power unit. Read value between 51 and 255.

**HL - High Local Limit:**

Value of the local setpoint limit. Adjustable by 'VIIim' potentiometer. Read value between 0 and 255.

**DT - Delay Triggerring:**

Value of the first firing delay in degree. Adjustable by 'DLY' potentiometer

Read value between 0 and 90.

**MI - Manufacturer Identifier:**

This parameter returns 'EUROTHERM Automation' as an ASCII character string (32 consecutive bytes read, starting at address 65280)

**CW - Command Word:**

This parameter is used to modify the operation of the digital communication. Codes and associated functions are given in the following table:

Command	Function
0	Inhibit firing
1	Enable firing
2 to 4	Not Used
5	Transfer waiting setpoint to active setpoint
6	Alarms Acknowledgement
7	PLF rating demand
8	PLF monitoring disabled

The operations coded 2,3,4,7 and 8 are stored in permanent memory

**GSW - General Status Word:**

This parameter indicates the status of the main alarms from 1 to 7 and the status of monitoring during the time between communication frames. The byte containing 0 to 7 may be read by Modbus function 7 (Quick Read). Bit definition:

Bit number	Definition
0	State '1': GRF alarm (TLF and THSC) active
1	State '1': PLF or TLF fault channel 1 (7100, 7200 and 7300)
2	State '1': PLF or TLF fault channel 2 (7200 and 7300 only)
3	State '1': PLF or TLF fault channel 2 (7200 and 7300 only)
4	Reserved
5	State '1': Power unit conduction stopped due to an alarm
6	State '1': Over-temperature alarm activated (fan-cooled unit)
7	State '1': Link failure with the communication option for S basic versions with DLF and A versions
8	State '1': Time-out exceeded
9 to 15	Not used

**SN - Serial Number:**

Each power units has a unique serial number at the address 65520

**V0 - Communication software version number**

**V1 - Board version number:**

This parameter is divided into bytes, Bits 8 to 15 correspond to the board version number and Bits 0 to 7 correspond to the software version number.

**DI - Device Identifier:**

This parameter is a unique factory-configured code which identified the type of unit.

Product name	Read Value
7300A	150

**MF - Modbus functions supported:**

Returns the value 186 (decimal) which means that the product supports the functions 3,7,8,16.

**CTO - Communication Time-Out:**

if the time between two valid frames exceeds the CTO the digital communication is inhibited. If the parameter is set to 0 monitoring is disabled.

The time-out is disabled by default (CTO = 0). The authorised values are between 1 s and 65535 s and are stored in permanent memory.

If the time-out is exceeded, the interface behaves as follows:

The green 'ON/Dxch' front panel LED, flashes at a frequency of 0.5 Hz, instead of being steady on. Bit 8 of the General Status Word is set to 1 and will be set to 0 when next read.

**STO - Setpoint after time-out:**

used to set the setpoint used if the time-out is exceeded.

Authorised values are between 0 and 255, stored in permanent memory.

The value in the 'Setpoint after time-out' parameter is transferred to the active setpoint if its value is higher.

**6.6. Remarks:**

If one parameter has no signification for the power unit used, the returned value is '1'. (e.g : Current limitation on front panel on a basic version)

For functioning safety reason, only some changes on the firing and control modes are allowed:

Basic unit (no option except digital comms), or unit with DLF option and overload alarm (ICO), the digital communication option allows:

For the firing modes: the changes between (AP, FC1, C16, C64 and SCA).

For the control modes: no changes are allowed if the firing mode is a burst firing, on the other hand, in phase angle the switch from U2 to Open Loop (OL) is allowed.

For other unit configuration the digital communication option allows:

For the firing modes: the switch between (FC1, C16, C64, SCA) to (PA or HC16) but not the other way round. It also allows the change between (FC1, C16, C64 and SCA) or between (PA or HC16) (see note 7).

For the control modes:

- If the unit is configured in PA, the following changes are allowed:
  - From  $U^2P$  to  $I^2$  and reciprocally
  - From  $U^2P$  to  $UxII^2$  and reciprocally (see note 4)
  - From  $I^2$  to  $UxII^2$  and reciprocally (see note 4)
  - From Open Loop (OL) or  $U^2$  to  $I^2$  but not the other way round (see note 5)
  - From OL or  $U^2$  to  $U^2P$  but not the other way round (see note 5)
  - From OL or  $U^2$  to  $UxII^2$  but not the other way round (see notes 4 and 5)
- If the unit is configured in burst firing mode, the following changes are allowed:
  - From V2CL to V1CL and reciprocally (this corresponds to a change between the control modes  $U^2$  and  $UxI$  with HC16 firing mode active, see note 2)
  - From  $U^2$  to V2CL but not the other way round (a current limitation is applied with  $U^2$  control threshold, see note 5)

#### NOTES:

1. On inductive loads FC1 or SCA is automatically switched to in C16 in order to avoid the
2. HC16 = (V2CL + C16) or (V1CL + C16) which is a C16 firing mode with current limitation by threshold (thyristor conduction angle limitation)
3. ( $U^2P$ ) = automatic transfer from a  $U^2$  control to a  $I^2$  control and reciprocally ( $UxII^2$ ) = automatic transfer from a  $UxI$  control to a  $I^2$  control and reciprocally
4. In order to be allowed, the out of factory configuration must be  $UxII^2$
5. When in  $I^2$  or V2CL control mode, it is possible to get back to  $U^2$  or OL control mode depending on the case, after having switched off the unit.
6. When switching from burst firing mode to phase angle, the control loop is reset to zero in order to achieve a ramp start.  
When switching from phase angle to burst of phase angle HC16, a ramp of angle is applied on the next conduction
7. On a factory configured unit with burst firing mode, and after a change to work in phase angle, getting back into burst firing mode is only possible after having switched off the unit.

With identical functions, digital communication settings are has priority on factory settings.

#### Important:

On 7300A products, there is no scale control or value validity sent via the digital communication option. In case of over flow, the value will not be saved.



## Chapter 7

### 7. MAINTENANCE

Contents	Page
7.3. Safety during maintenance .....	7-2
7.2. Maintenance .....	7-2
7.3. Thyristor protection fuses .....	7-3

## 7. Chapter 7 - MAINTENANCE

### 7.1. SAFETY DURING MAINTENANCE

Please read carefully before commissioning the thyristor unit

**Important!**



- Eurotherm shall not be held responsible for any damage, injury, losses or expenses caused by inappropriate use of the product or failure to comply with this manual.
- Accordingly the user is responsible for checking, before commissioning the unit, that all the nominal characteristics correspond to the conditions under which it is to be installed and used.

**Danger!**



- The product must be commissioned and maintained by qualified personnel, authorised to work in an industrial low voltage environment. Users must not attempt to access internal parts. The heatsink temperature may exceed 100°C. The heatsink remains hot for approx. 15 minutes after the unit is shut down. Avoid touching the heatsink even briefly while the unit is operating.

### 7.2. MAINTENANCE

- Every six months, check that the power and protective earth cables are correctly **tightened** (see 'Wiring' section, page 2-6).
- If the load parameters **change**, the operation of the PLF detection must be diagnosed (see 'DLF option' section).
- If a **DLF alarm** occurs, check the load wiring and condition of contacts. Use the push button to **confirm** the DLF alarm **diagnosis** (see page 5-10).
- To ensure that the unit is cooled correctly, the heatsink should be **cleaned** regularly, depending on how dirty the environment is, as should the fan protection grille for fan-cooled units rated at 125A or more.

**Danger!**



The thyristor unit should be cleaned only when powered down and at least 15 minutes after stopping operation.

### 7.3. THYRISTOR PROTECTION FUSES

The thyristors in the 7300A power thyristor unit are protected against excess currents by high-speed fuses (for all load types other than short wave infrared elements). For current ratings **100A** the fuses are **external**.

#### Danger!



High-speed fuses do not provide protection for the installation.  
Upline protection must be fitted (non-high-speed fuses, circuit breakers, cut-outs).

The product code specifies whether or not a fuse is present.

With the **FUSE** or **MSFU** (Micro Switch **FU**se) codes, fuses and fuse-holder assembly (corresponding to the current rating) are supplied with the product.

- for code **FUSE**, the fuses is not fitted with a **striker bar**.
- for code **MSFU**, the fuses has a **striker bar** and the fuse-holder is fitted with a blown fuse **microswitch**.

If the user does not order a thyristor protection fuse or if a short wave infrared load is used, **no fuses is supplied** (code **NONE**).

Rating	A fuse part number	Fuses and fuse-holder assembly			
		Part number	Dimensions (mm)		
			H x	W x	D
16A	CH260034	FU3038/16A	77 x	54 x	61
25A	CH260034	FU3038/25A	77 x	54 x	61
40A	CH330054	FU3451/40A	106 x	78 x	76
63A	CS173087U080	FU3258/63A	124 x	104 x	76
80A	CS173087U100	FU3258/80A	124 x	104 x	76
100A	CS173246U160	FU3760/100A	146 x	120 x	94

Table 7-1 Fuses without microswitch, recommended for ratings 16A to 100A (code **FUSE**)

Rating	A fuse part number	Fuses and fuse-holder assembly			
		Part number	Dimensions (mm)		
			H x	W x	D
16A	CS176513U032	MSFU3451/16A	77 x	54 x	61
25A	CS176513U032	MSFU3451/25A	77 x	54 x	61
40A	CS176513U050	MSFU3451/40A	106 x	78 x	76
63A	CS176461U080	MSFU3258/63A	124 x	104 x	76
80A	CS176461U100	MSFU3258/80A	124 x	104 x	76
100A	CS173246U160	MSFU3760/100A	146 x	120 x	94

Table 7-2 Fuses with microswitch, recommended for ratings 16A to 100A (code **MSFU**)

Rating	Fuse part number with or without fuse-holder assembly internal fuse
125A	CS176762U160
160A	CS176762U315

Table 7-3 Internal Fuses recommended for ratings  $\geq 125$  A (code **FUSE** or **MSFU**)



#### Important!

For all loads (other than short wave infrared elements), using a thyristor protection fuse **other than** the recommended fuse **voids** the product guarantee.

---

# EUROTHERM

For over thirty years **Eurotherm Limited** have been providing an unparalleled level of service and expertise to customers in the control of Processes and Power.

From requirement assessment, through to equipment specification and plant commissioning.

**Eurotherm Limited** is able to offer expertise and equipment in the following areas:

- Input conditioning
- Process and Temperature Indicators
- Single Loop Process and Temperature Controllers with Programming facilities
- Programmable Multi loop Process Controllers
- Solid State Contactors
- Power Controllers
- Paper and Paperless Data Recorders
- Data Acquisition and Management Instrumentation
- Supervisory Systems (SCADA)
- Process Automation Systems

**Eurotherm Limited** is part of the **Production Management Division** of **Invensys plc**, one of the world's leading automation and controls companies.

**Eurotherm** manufactures at a number of locations in Europe and the USA, and is a major supplier to the world's processing and manufacturing industries.

The company is ISO9001 approved and operates TickIT protocols for software management.

Please contact your local **Sales Office**.

# EUROTHERM WORLDWIDE SALES AND SERVICE

## AUSTRIA

Eurotherm GmbH  
Tel +43 (1) 798 7601  
Fax +43 (1) 798 7605  
Web: www.eurotherm.at

## AUSTRALIA

Eurotherm Pty. Ltd.  
Tel +61 (2) 9838 0099  
Fax +61 (2) 9838 9288  
Web: www.eurotherm.com.au

## BELGIUM & LUXEMBOURG

Eurotherm BeLux  
Tel +32 (0) 85 274080  
Fax +32 (0) 85 274081  
Web: www.eurotherm.nl

## BRAZIL

Eurotherm Ltda  
Tel +55 (19) 3707 5333  
Fax +55 (19) 3707 5345  
Web: www.eurothermltda.com.br

## DENMARK

Eurotherm AS  
Tel +45 (70) 234670  
Fax +45 (70) 546253  
Web: www.eurothermltda.se

## GERMANY

Eurotherm Regler GmbH  
Tel +49 (64) 31 2980  
Fax +49 (64) 31 298119  
Web: www.eurotherm-deutschland.de

## HONG KONG

Eurotherm Limited  
Tel +85 (2) 2873 3826  
Fax +85(2) 2870 0148  
Web: www.hongkong.com

## FRANCE

Eurotherm Automation SAS  
Tel +33 (0) 4 78 66 45 00  
Fax +33 (0) 4 78 35 24 90  
Web: www.eurotherm.tm.fr

## INDIA

Eurotherm India Limited  
Tel +91 (44) 24961129  
Fax +91 (44) 24961831

## IRELAND

Eurotherm Ireland Limited  
Tel +353 (0) 1 4691800  
Fax +353 (0) 1 4691300  
Web: www.eurotherm.tm.ie

## ITALY

Eurotherm SRL  
Tel +39 (031) 9751111  
Fax +39 (031) 977512  
Web: www.eurotherm.it

## JAPAN

Densei-Lambda KK Eurotherm  
Tél : (+03) 5714 0620  
Fax : (+03) 5714 0621  
Web : www.nemic.co.jp

## KOREA

Eurotherm Korea Limited  
Tel +82 (0) 31 273 8507  
Fax +82 (0) 31 273 8508  
Web: www.eurotherm.co.kr

## NETHERLANDS

Eurotherm B.V.  
Tel +31 (172) 411 752  
Fax +31 (172) 417 260  
Web: www.eurotherm.nl

## NORWAY

Eurotherm AS  
Tel +47 (67) 59 21 70  
Fax +47 (67) 11 83 01  
Web: www.eurotherm.se

## SPAIN

Eurotherm España SA  
Tel +34 (91) 6616001  
Fax +34 (91) 6619093  
Web: www.eurotherm.es

## SWEDEN

Eurotherm AB  
Tel +46 (40) 384500  
Fax +46 (40) 384545  
Web: www.eurotherm.se

## SWITZERLAND

Eurotherm Produkte AG  
Tel +41 (44) 7871040  
Fax +41 (44) 7871044  
Web: www.eurotherm.ch

## UNITED KINGDOM

Eurotherm Limited.  
Tel. +44 (0) 1903 268500  
Fax +44 (0) 1903 265982  
Web: www.eurotherm.co.uk

## U.S.A.

Eurotherm Controls Inc.  
Tel +1(703) 443 0000  
Fax +1(703) 669 1300  
Web: www.eurotherm.com

**Manufactured by Eurotherm Automation**

© Copyright Eurotherm Limited 2002

All rights strictly reserved. No part of this document may be stored in a retrieval system, or any form or by any means without prior written permission from Eurotherm Limited.

Every effort has been taken to ensure the accuracy of this specification. However in order to maintain our technological lead we are continuously improving our products which could, without notice, result in amendments or omissions to this specification.

