

B. SUPPLEMENT 2704 MASTER COMMUNICATIONS 2

- B.1. INTRODUCTION2**
- B.1.1. Broadcast Communications.....2
- B.1.2. Direct read/write.....2
- B.2. INSTALLATION.....3**
- B.3. WIRING CONNECTIONS.....3**
- B.3.1. Example Wiring RS422 for Different Slaves4
- B.4. SWITCH ON.....5**
- B.4.1. Basic Navigation5
- B.5. TO CONFIGURE PARAMETERS6**
- B.6. TO CONFIGURE SLAVES.....8**
- B.7. PARAMETER TABLES.....9**
- B.7.1. IEEE.....12
- B.7.2. Configuration mode.....13

For further information please refer to:-

2704 Engineering Handbook, Part No. HA026933

2704 Installation and Operation Handbook Part No. HA026502

2000 Series Communications Handbook, Part No. HA026230

These may be found on //http://www.eurotherm.co.uk/pdfs

B. Supplement 2704 Master Communications

B.1. INTRODUCTION

Software version 5 and above of the 2704 controller supports Master Communications. The objective of the master comms is to allow the 2704 to communicate with any instrument using ModBus interface as a master device, that is, without the need for a supervisory PC. This allows the 2704 to link through digital communications with other products to create a small system solution. There are two methods of communication:-

1. Broadcast Communications
2. Direct Read/Write

B.1.1. Broadcast Communications

The 2704 master can be connected to up to 32 slaves. The master sends a unit address of 0 followed by the address of the parameter which is to be sent. A typical example might be a multi zone oven where the setpoint of each zone is required to follow, with digital accuracy, the setpoint of a master.

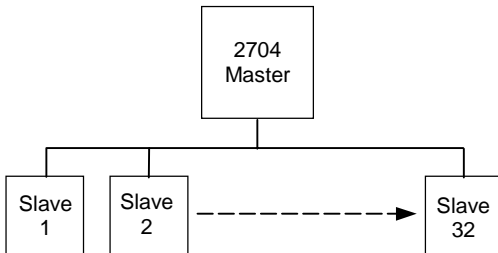

B.1.2. Direct read/write

The 2704 master can be connected to up to eight slaves. Each slave has its own unit address. The master can send data to each slave by sending a unit address followed by the parameter address. It can also request data from a slave. This data may be displayed on the 2704 or used as part of a 2704 control strategy.

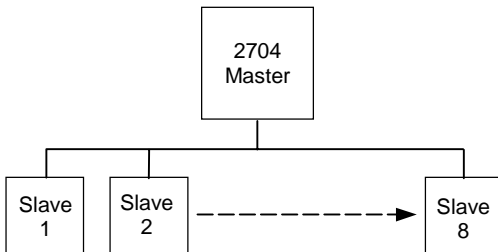

B.2. INSTALLATION

The 2704 Master Communications controller should be installed as described in Chapter 2 of the Installation and Operation Handbook.

WARNING



You must ensure that the controller is correctly configured for your application. Incorrect configuration could result in damage to the process being controlled, and/or personal injury. It is your responsibility, as the installer, to ensure that the configuration is correct. See 2704 Engineering Handbooks for details.

B.3. WIRING CONNECTIONS

Before proceeding further, please read Appendix B, Safety and EMC information, in the above handbooks.

The Digital Communications module for the master/slave controller is fitted in Comms Module slot J and uses terminals JA to JF. The connections are identical to the RS485 2-wire standard or RS422 4-wire standard as described in further detail in the 2000 series Communications Handbook.



**Note: Rx connections in the master are wired to Tx connections of the slave
Tx connections in the master are wired to Rx connections of the slave**

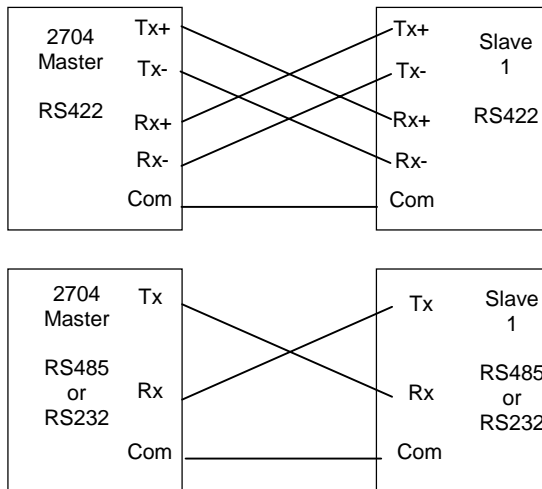

Figure B-1: Master/Slave Connections

B.3.1. Example Wiring RS422 for Different Slaves

The diagram below shows connections for a range of different controllers using RS422. These are representative of typical slaves which may be used but could also include third party products using Modbus protocol.

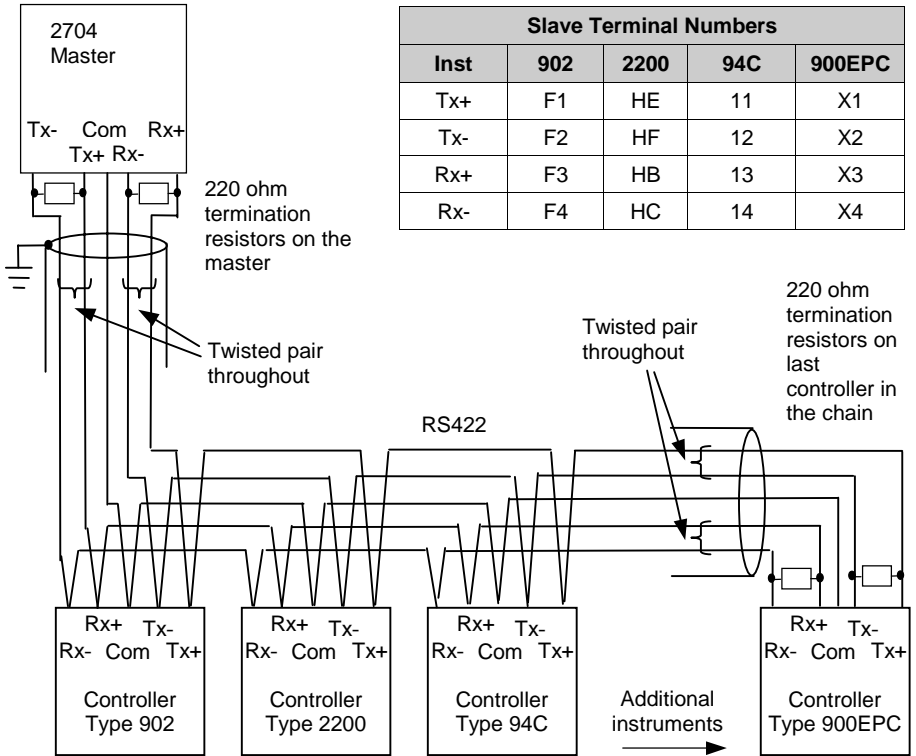

Figure B-2: Example Wiring RS422 for Different Slaves

B.4. SWITCH ON

A short self test sequence takes place during which the controller identification is displayed together with the version number of the software fitted. For master communications the version number must be greater than 5.0.



An overview display will then be shown. The format of this display will depend upon the process application for which the controller has been configured. Some typical overviews are shown in both the Operation and Engineering Handbooks.

Figure B-3: An Example of Overview Display

Note: If master comms is fitted as an upgrade, check also the crossboard version before configuring master comms. This parameter can be found in configuration level in 'INSTRUMENT (Info Page)' 'CBC Version' and must be greater than 4.7 (displayed as 47).

To configure the controller for master communications it will be necessary to navigate to configuration access level (see Engineering Handbook). A summary of navigation is shown below.

B.4.1. Basic Navigation

Parameters are organised into pages. Each page is given a name or header which describes a particular subject – in this case 'MASTER COMMS'

The MASTER COMMS page is divided into sub-headings, for example 'Parameters', 'Slave 1', etc

Parameters for the chosen subject are found in these pages

To change the value of alterable parameters

- press to access the page
- press or to select the header
- press to access
- press or to select the header
- press again
- press or

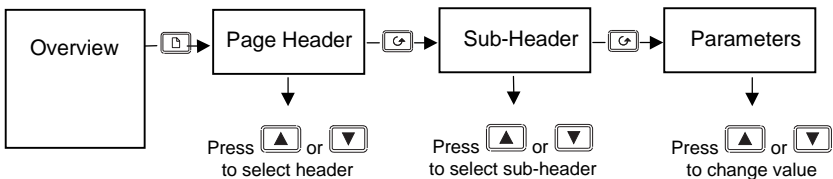





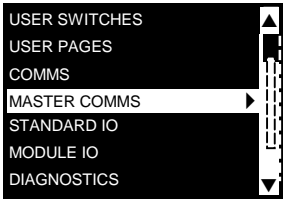



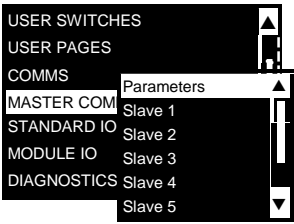



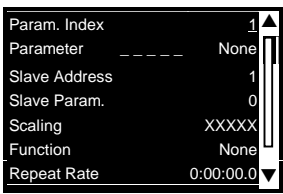



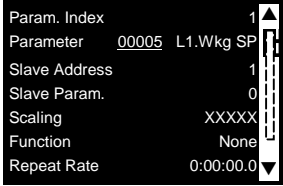



Figure B-4: Summary of Basic Navigation

Examples are shown in the following two sections



B.5. TO CONFIGURE PARAMETERS

Set controller access level to **'Config'** as described in the Engineering Handbook.

The parameters required to configure a transaction between a local parameter in the master and a parameter in the slave are shown in Table 1. To configure these parameters:-

Do This	This Is The Display You Should See	Additional Notes
<p>1. From any display press  as many times as necessary to access the page header menu</p> <p>2. Press  or  to scroll to 'MASTER COMMS'</p>		
<p>3. Press  to display master comms sub-headings</p> <p>4. Press  or  to scroll around the list and choose 'Parameters'</p>		<p>These parameters configure a transaction between a local parameter in the 2704 and a parameter in a slave.</p>
<p>5. Press  to select the parameters in this list</p> <p>6. Press  again to edit the required parameter, in this case 'Param Index'</p> <p>7. Press  or  to index the parameter 1 to 38</p>		<p>The flashing underline indicates the value can be changed</p>
<p>8. Now press  to select the 'Parameter' in the master</p> <p>9. Press  or  to set the Modbus address of the parameter</p>		<p>Commonly used parameters (see App. D - Engineering Handbook) are followed by a short description. To edit the parameter using this description press  followed by  or </p> <p style="text-align: right;">Parameter 00005 L1.Wkg SP</p>

10. Now press  to select the address of the slave in which to send (or receive) the parameter.

11. Press  or  to change the value

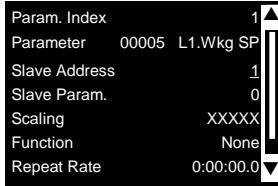

In this example the slave address is 1.

For broadcast comms set this value to 0

12. Now press  to select 'Slave Parameter' address

13. Press  or  to change the value

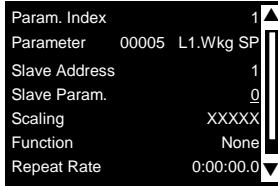

Range 0 to 65535. This full range is only necessary for IEEE. It is necessary to give the full IEEE address to get true floating point. For example in Eurotherm controllers PV = 8000 Hex or 32767. (See also section B.8.1.)

14. Now press  to select 'Scaling' for the parameter

15. Press  or  to change the value

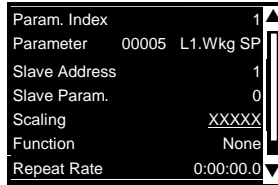

See table 1 for choices

16. Now press  to select 'Function'

17. Press  or  to change the value



This sets the function to be read or write. See table 1 for full list of choices

18. Now press  to select 'Repeat Rate'

19. Press  or  to change the value

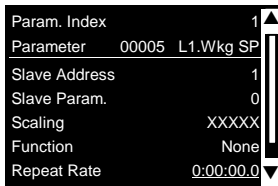







This sets the time between transmissions. 0 = continuous

B.6. TO CONFIGURE SLAVES

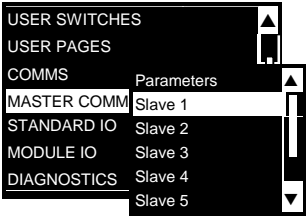
The controller must be in 'config' mode.

The parameters required to configure the characteristics of the slaves are shown in Table 2. To configure the slave parameters:-

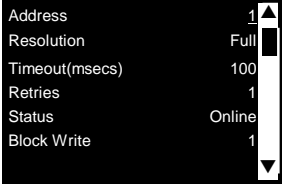
Do This	This Is The Display You Should See	Additional Notes
<p>2. From the sub-headers menu press  or  to select the required slave</p>		<p>Up to eight slaves can be configured</p>
<p>3. Press  to select the parameters in this list</p> <p>4. Press  again to edit 'Address'</p> <p>5. Press  or  to change the value</p>		<p>The flashing underline indicates the value can be changed.</p> <p>The slave address is in the range 0 to 254 and does not necessarily have to be the same as the slave number.</p> <p>0 is reserved for broadcast comms.</p>
<p>Repeat 3 and 4 to set up following parameters.</p>		<p>See table 2 for a description of the parameters and settings</p>

B.7. PARAMETER TABLES

Table Number: 1		These parameters configure a transaction between a local parameter in the 2704 and a parameter in a slave.		MASTER COMMS (Parameter Page)	
Parameter Name	Parameter Description	Value	Default	Access Level	
Param. Index	Select up to 38 parameters to read or write to.	1 to 38			
Parameter	The address of the parameter in the 2704 which is to be sent to a slave. OR the address in the 2704 in which a parameter sent from a slave is stored.	modbus address shown as 'address' followed by 'name of commonly used parameter'			
Slave Address	The address of the slave where the parameter is to be sent or received. 0 is broadcast mode in which the parameter is sent to all slaves	0 to 254			
Slave Param.	The parameter address in the slave	0 to 65535			
Scaling	Scaling of the parameter in the slave No. of decimal points Time transmitted as seconds Time transmitted as minutes Time transmitted as hours Time transmitted as tenths of seconds Time transmitted as tenths of minutes Time transmitted as tenths of hours IEEE Float 32 bit (see section B.8.1) Time transmitted as 32 bit msec	 XXXXX sss mmm hhh ss.s mm.m hh.h Euro REAL Euro TIME			

<p>Function See Note 1 below</p>	<p>Disables the transaction Set to Read(3) for parameters with modbus function code 3 Set to Read(4) for parameters with modbus function code 4 Set to Write to write at a repeat rate Set to Change Write to write only if the parameter value has changed</p>	<p>None Read(3) Read(4) Write Change Write</p>		
<p>Repeat Rate</p>	<p>Time between transmissions. 0 is continuous</p>	<p>0 to 99:59:59.9</p>		
<p>Status</p>	<p>Set to good on leaving config Slave returned illegal address Slave returned illegal value Slave returned Modbus exception Error in message returned by slave Value read was out of limits or the parameter is unalterable Parameter is OEM secured and will not be transmitted No response from slave The master has no parameter associated with the specified modbus address. Config only Parameter value unchanged since last transmit. Relevant to change write only. The slave does not support block write</p>	<p>Good Addr Error Data Error Error Failed Store Error Secured Timed Out No Parameter Unchanged No Block Write</p>		

Note 1:-

Function codes are a single byte instruction to the slave describing the action to perform.

Function code 3 – Read Output Registers - allows the binary contents of holding registers to be obtained from the addressed slave.

Function code 4 – Read Input Registers – obtains the contents from input registers of the addressed slave.

For the 2000 range of controllers either function code can be used. For other slaves refer to the manufacturers documentation.

Table Number: 2		These parameters configure the characteristics of the slaves		MASTER COMMS (Slave1 to 8 Page)	
Parameter Name	Parameter Description	Value	Default	Access Level	
Address	The modbus address of the slave	0 to 254			
Resolution	To set resolution configured in the slave to Full or Integer	Full Integer	Full		
Timeout(msecs)	Time to wait for a response from a slave	20 to 2000	100mS		
Retries	Number of times to retry before the status goes to 'Timed Out'	1 to 100	1		
Status	Offline and Online are user selectable. If the transaction is not completed in the time set by the 'Timeout' parameter in the specified number of 'Retries' the message 'Timeout' will be displayed. The message 'Recovering' appears fleetingly	Offline Online Timed Out Recovering			
Block Write	Set to the maximum block size supported by the slave. For IEEE this must be set to >0 (see also section B.8.1)	0 to 100	0		

B.8. ADDITIONAL NOTES

B.8.1. IEEE in 2000 Series

This section applies specifically to 2000 series instruments. If the slave is not a series 2000 instrument a knowledge of the communications format for the slave is required.

One of the main limitations of Modbus is that only 16 bit integer representations of data can normally be transferred. In most cases, this does not cause a problem, since appropriate scaling can be applied to the values without losing precision. If the slave is a series 2000 instrument, where all values are shown on a 4 digit display, values may be transferred in this way. However this has the significant drawback that the scaling factor to be applied needs to be known at both ends of the communications link.

One further problem is that certain 'time' parameters, notably those used for the programmer function can be returned over the communications link in tenths of seconds, minutes or hours. It is possible, therefore, for long durations to overflow the 16 bit Modbus limit.

To overcome these problems, a sub protocol has been defined, using the upper portion of the Modbus address space (8000h and upwards), allowing full 32 bit resolution floating point and timer parameters. This upper area is known as the IEEE region.

This sub-protocol provides two consecutive Modbus addresses for all parameters. The base address for any given parameter in the IEEE region can easily be calculated by taking its normal Modbus address, doubling it, and adding 8000h. For example, the address in the IEEE region of the Target Setpoint (Modbus address 2) is simply

$$2 \times 2 + 8000h = 8004h = 32772 \text{ decimal}$$

This calculation applies to any parameter in a series 2000 slave that has a Modbus address.

Access to the IEEE area is made via block reads (Functions 3 & 4) and writes (Function 16). Attempts to use the 'Write a Word' (Function 6) operation will be rejected with an error response. Furthermore, block reads and writes using the IEEE region should only be performed at even addresses, although no damage to the instrument will result in attempting access at odd addresses. In general, the 'number of words' field, in the Modbus frame, should be set to 2 times what it would have been for 'normal' Modbus.

The rules governing how the data in the two consecutive Modbus addresses are organised depending on the 'data type' of the parameter.

See also 'Series 2000 Communications Handbook Chapter 7.

B.8.2. Configuration mode

The Master does not communicate in configuration mode.

During configuration, if there is no parameter in the master with the specified modbus address the Status is set to 'No Parameter' and on exit from configuration mode all parameters defining that transaction are set to their cold start values.

Parameter Name	Cold Start Value
Parameter	None
Slave Address	1
Slave Parameter	0
Repeat Rate	0:00:00.0
Function	None
Scaling	XXXXX
Status	Good

